

- NOTES:
1. ALL DIMENSION IN MM [INCH]
  2. GENERAL TOLERANCE: X.X=±0.4  
X.XX=±0.25
  3. TERM. NOS. FOR REF. ONLY
  4. CONTACT RATING SWITCHING: 150mA, 250V AC/DC  
350mA, 110V AC/DC
  5. OPERATING FORCE: 425±100 CM/STANDARD
  6. OPERATING TEMP: -30° to 85°C
  7. CIRCUIT SP: 8 POSITIONS, 30° INDEX.
  8. DIELECTRIC STRENGTH: 1000V RMS min.@Sea Level
  9. DESIGNATE MAJOR DIMENSIONS
  10. TIMING: BBM (Non-Shorting) Break Before Make.
  11. HARDWARE SUPPLIED ON SWITCH- SEE BELOW  
STOP RING, LOCKWASHER, & HEXNUT

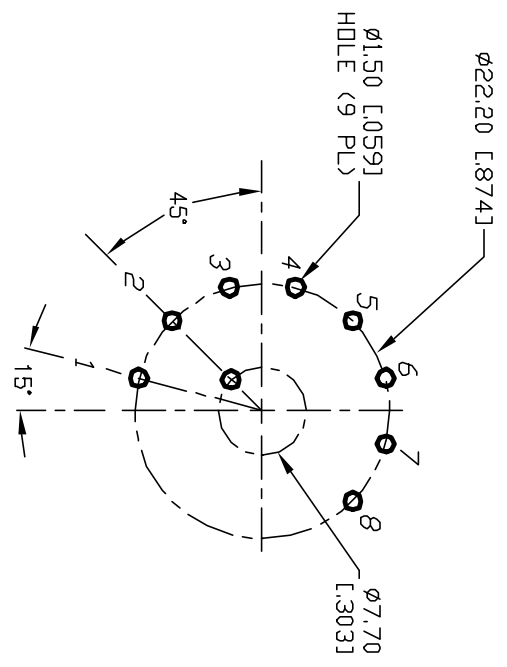
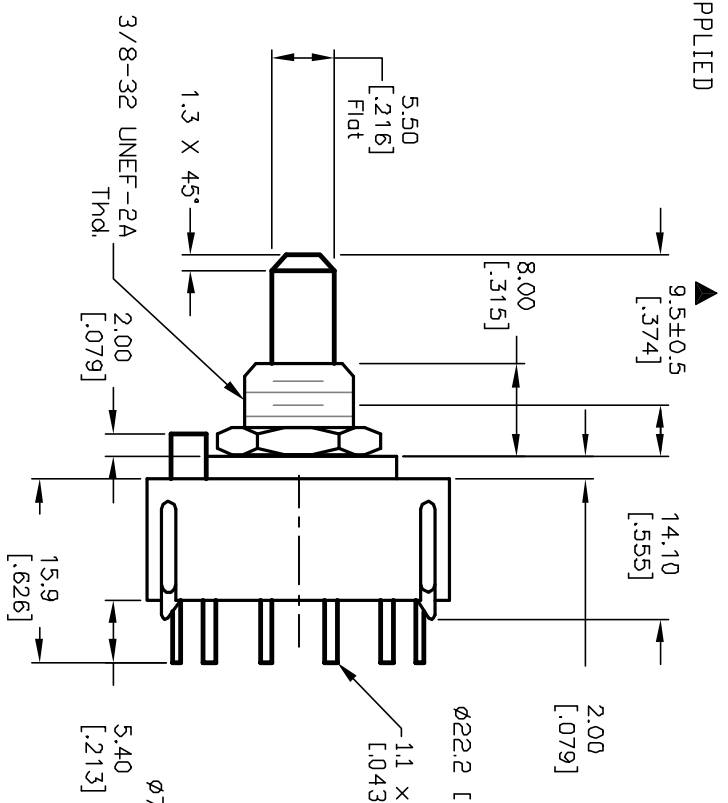
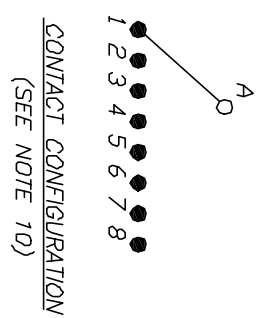
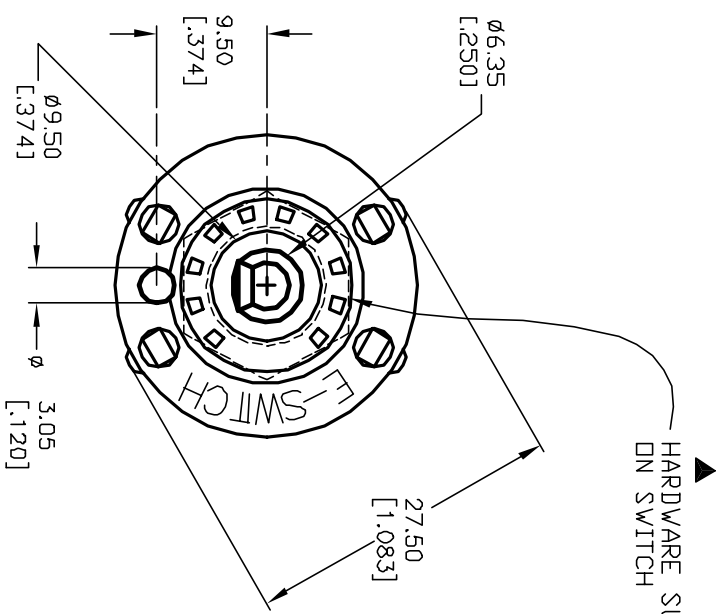

**E-SWITCH®**

C	12821	REV	DESC PER NEW CATALOG	2/28/03	CJB
B	11512	REV	RELEASED FOR PRODUCTION	5/30/01	CJB
REV.	ECN No.	DESCRIPTION		DATE	CHKD

TITLE		SCALE	DATE	DR	DWG	REV
KC-18-A-(9.5mm) 01-N-P-S		1.5:1	5/30/01	CJB	G530161	C

THE INFORMATION CONTAINED IN THIS DOCUMENT IS PROPRIETARY TO E-SWITCH AND IS NOT TO BE COPIED OR TRANSFERRED