

- NOTES:
1. ALL DIMENSION IN MM [INCH]
 2. GENERAL TOLERANCE: X.X=±0.4
X.XXX=±0.25
 3. TERM. NOS. FOR REF. ONLY
 4. CONTACT RATING SWITCHING: 150mA, 250V AC/DC
350mA, 110V AC/DC
 5. OPERATING FORCE: 425±100 CM/STANDARD
 6. OPERATING TEMP: -30° to 85°C
 7. CIRCUIT SP: 8 POSITIONS, 30° INDEX.
 8. DIELECTRIC STRENGTH: 1000V RMS min.@Sea Level
 9. DESIGNATE MAJOR DIMENSIONS
 10. TIMING: BBM (Non-Shorting) Break Before Make.
 11. HARDWARE SUPPLIED ON SWITCH- SEE BELOW
STOP RING, LOCKWASHER, & HEXNUT

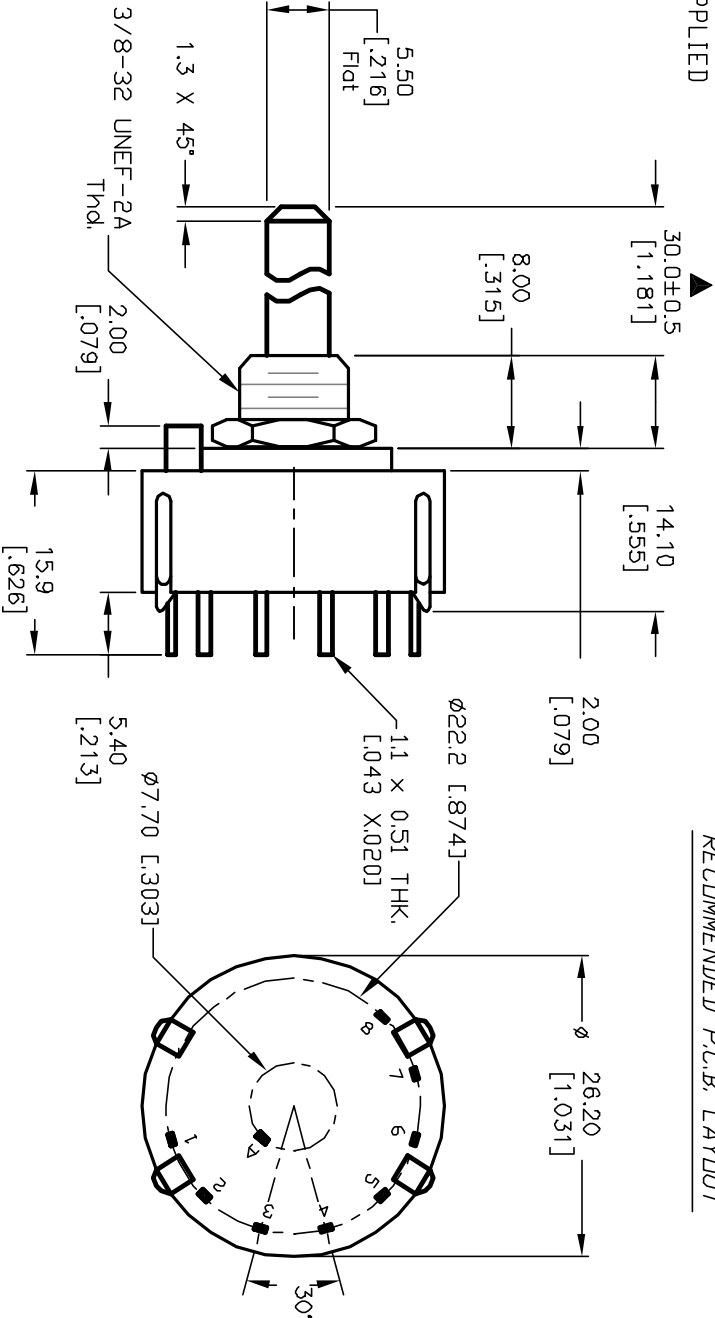
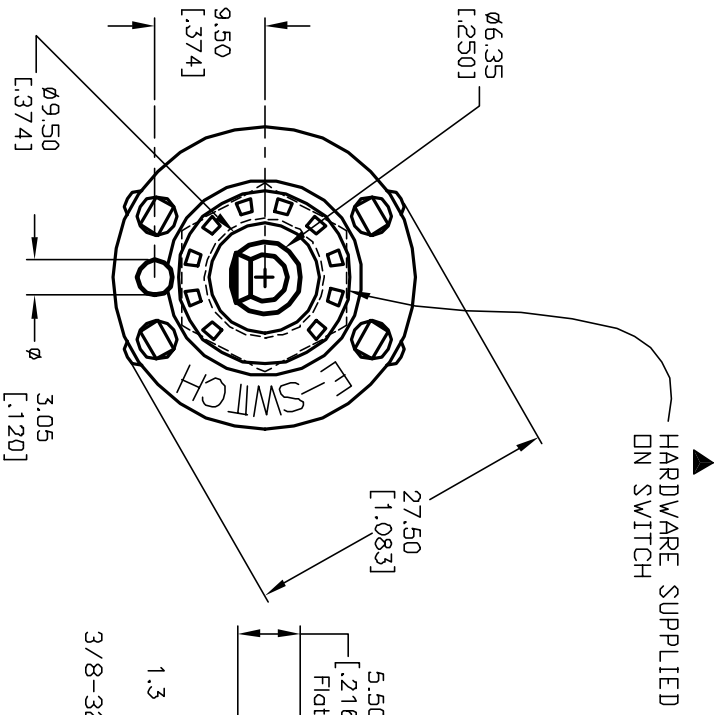
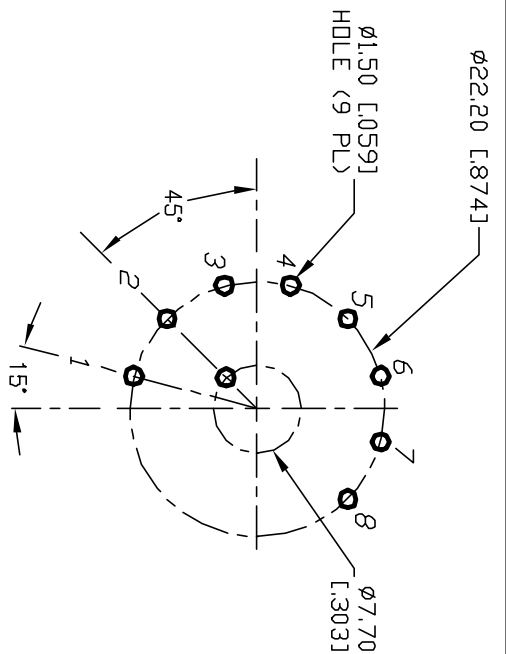
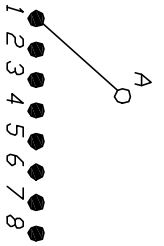

B		12821	REV DESC PER NEW CATALOG	2/28/03	CJB	TITLE	SCALE	DATE	DR	DWG	REV
A		11512	RELEASED FOR PRODUCTION	5/30/01	CJB	KC-18-A-(30.0mm) 01-N-P-S	1.5:1	5/30/01	CJB	G530163	B
REV.		ECN No.	DESCRIPTION	DATE	CHKD						
<p>THE INFORMATION CONTAINED IN THIS DOCUMENT IS PROPRIETARY TO E-SWITCH AND IS NOT TO BE COPIED OR TRANSFERRED</p>											

E-SWITCH®