

NOTES:

1. ALL DIMENSION IN MM [INCH]
2. GENERAL TOLERANCE: X.X=±0.4
X.XX=±0.25
3. TERM. NOS. FOR REF. ONLY
4. CONTACT RATING SWITCHING: 150mA, 250V AC/DC
350mA, 110V AC/DC
5. CONTACT RATING (NON-SWITCHING) 5A
6. CONTACT MATERIAL: SILVER over COPPER ALLOY.
7. OPERATING FORCE: 425±100 CM/STANDARD
8. OPERATING TEMP: -30° to 85°C
9. CIRCUIT SP: 6 POSITIONS, 30° INDEX.
10. DIELECTRIC STRENGTH 1000V RMS min. @ SEA LEVEL
11. DESIGNATE MAJOR DIMENSIONS
12. SUPPLIED HARDWARE: LOCK NUT AND WASHER (NOT SHOWN).

CONTACT CONFIGURATION
Timing: Non-Shorting (BBM)

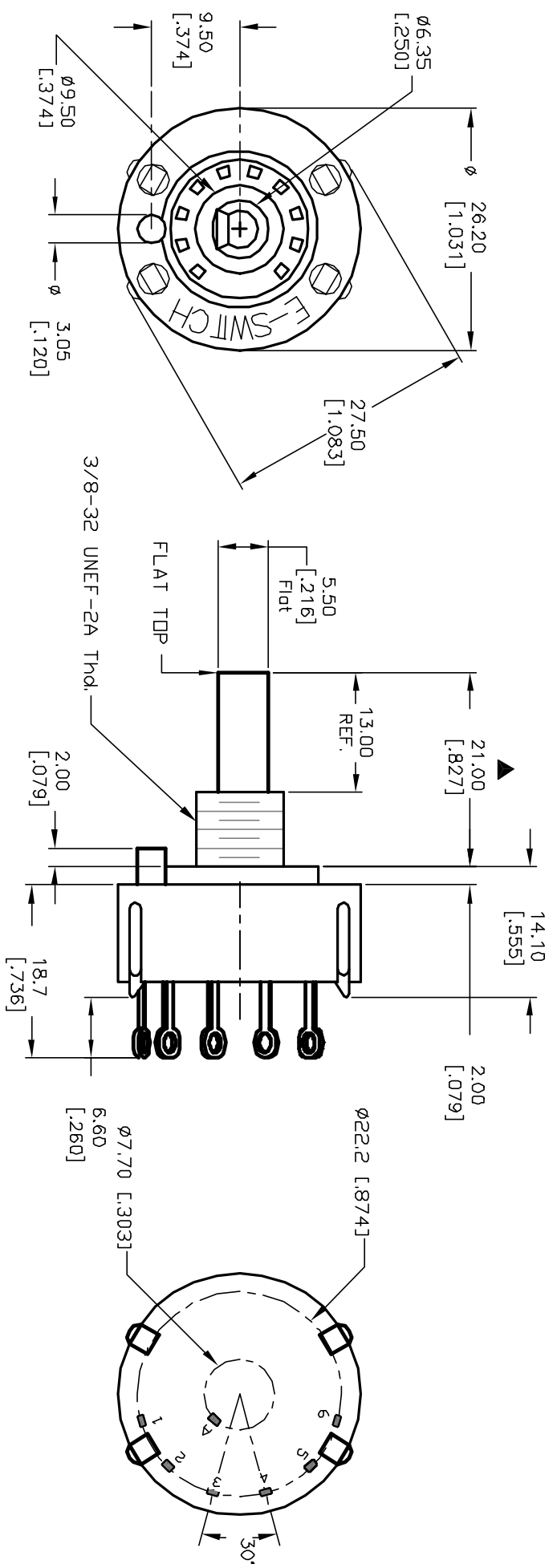
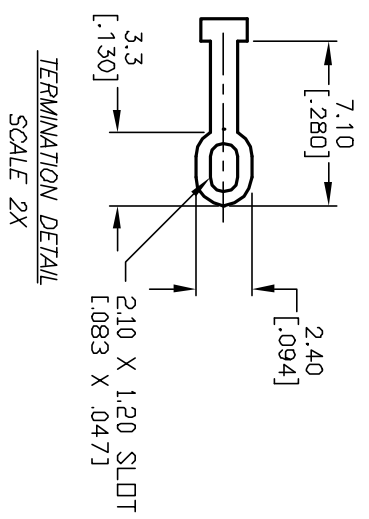
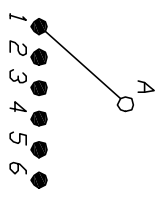

E-SWITCH®

REV.	ECN No.	DESCRIPTION	DATE	CHKD	SCALE	DATE	DR	DWG	REV
A	12615	RELEASED FOR PRODUCTION	12/5/02	CJB	1.5:1	12/5/02	CJB	G510710	A
TITLE					KC-16-A (13.0mm) 01-N-L-S				
THE INFORMATION CONTAINED IN THIS DOCUMENT IS PROPRIETARY TO E-SWITCH AND IS NOT TO BE COPIED OR TRANSFERRED									