

NOTES:

1. ALL DIMENSION IN MM [INCH]
2. GENERAL TOLERANCE: X.X=±0.4  
X.XX=±0.25
3. TERM. NOS. FOR REF. ONLY
4. CONTACT RATING SWITCHING: 150mA, 250V AC/DC  
350mA, 110V AC/DC
5. CONTACT RATING (NON-SWITCHING) 5A
6. CONTACT MATERIAL:  
STANDARD SILVER over COPPER ALLOY
7. OPERATING FORCE: 425±100 CM/STANDARD
8. OPERATING TEMP.: -30° to 85°C
9. CIRCUIT SP: 5 POSITIONS, 30° INDEX,
10. DIELECTRIC STRENGTH 1000V RMS min. @ SEA LEVEL
11. HARDWARE SUPPLIED ON SWITCH- SEE BELOW  
STOP RING, LOCKWASHER, & HEXNUT
12. ▲ DENOTES CRITICAL PARAMETER.

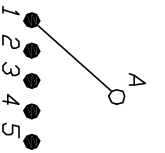

CONTACT CONFIGURATION  
Timing: NON-SHORTING (BBM)

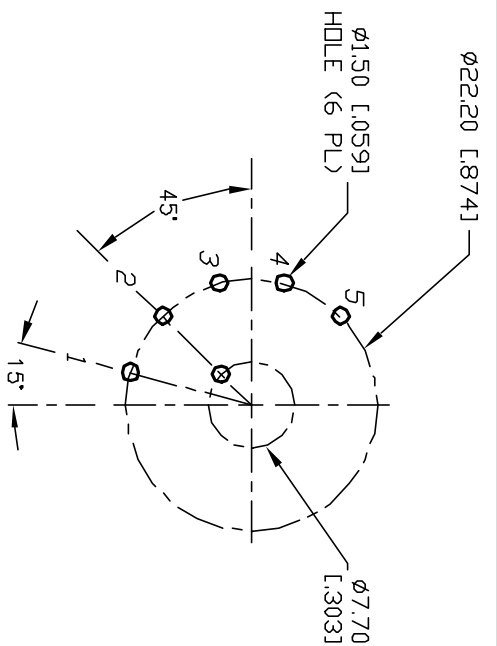

RECOMMENDED P.C.B. LAYOUT

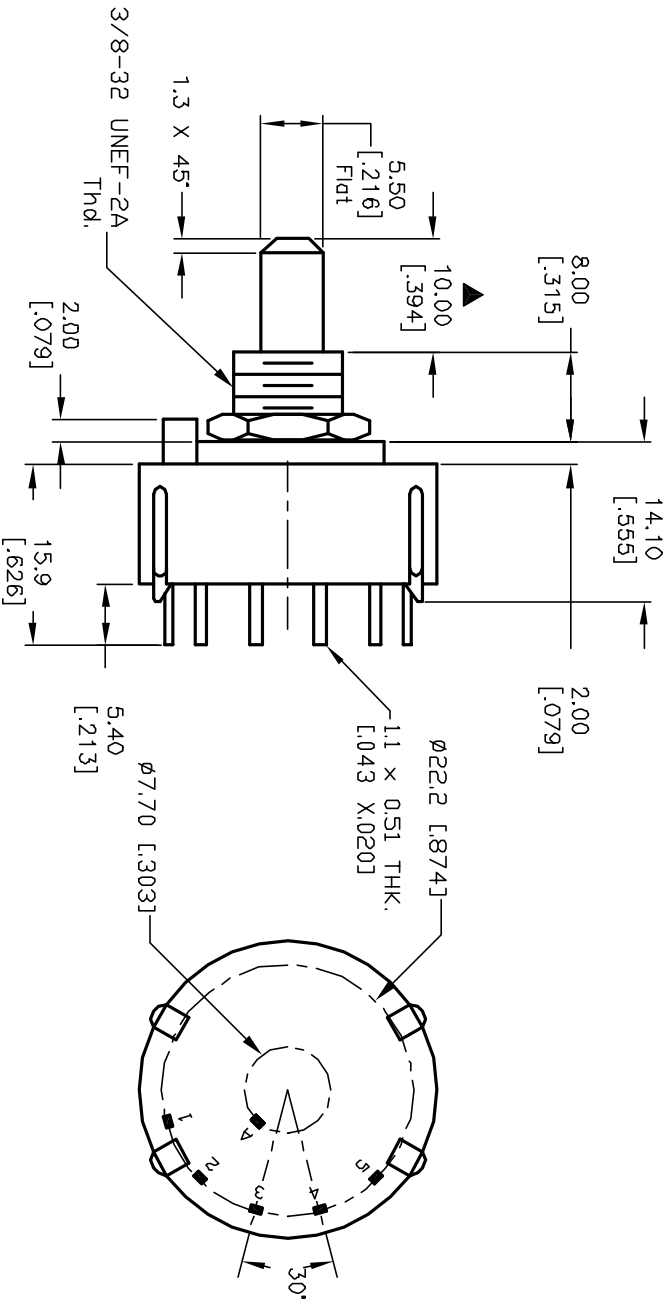
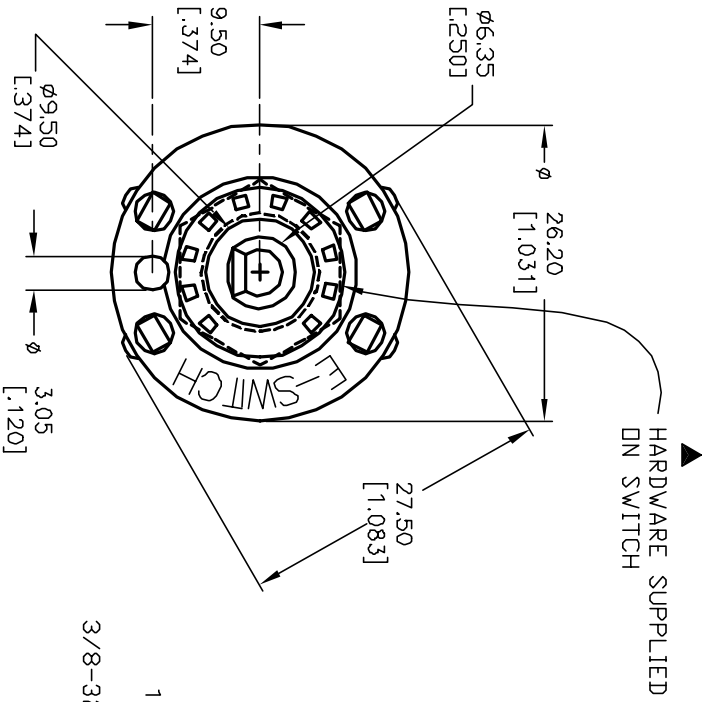

A		13148	RELEASED FOR PRODUCTION	5/22/03	AR	TITLE	
REV.	ECN No.	DESCRIPTION		DATE	CHKD	KC15A10.001NPS	
<b>E-SWITCH®</b>							
SCALE		1.5:1		DATE	5/22/03	DR	AR
REV		A		DWG	G527542		

THE INFORMATION CONTAINED IN THIS DOCUMENT IS PROPRIETARY TO E-SWITCH AND IS NOT TO BE COPIED OR TRANSFERRED