

- NOTES:
1. ALL DIMENSION IN MM [INCH]
 2. GENERAL TOLERANCE: X.X=±0.4
X.XX=±0.25
 3. TERM. NOS. FOR REF. ONLY
 4. CONTACT RATING SWITCHING: 150mA, 250V AC/DC
350mA, 110V AC/DC
 5. CONTACT RATING (NON-SWITCHING) 5A
 6. CONTACT MATERIAL: SILVER OVER COPPER ALLOY
 7. OPERATING FORCE: 425±100 CM/STANDARD
 8. OPERATING TEMP: -30° to +85°C
 9. CIRCUIT SP: 2 POSITIONS, 30° INDEX
 10. DIELECTRIC STRENGTH 1000V RMS min. @ SEA LEVEL
 11. DESIGNATE MAJOR DIMENSIONS

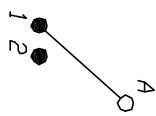

CONTACT CONFIGURATION
Timing: Non-Shorting

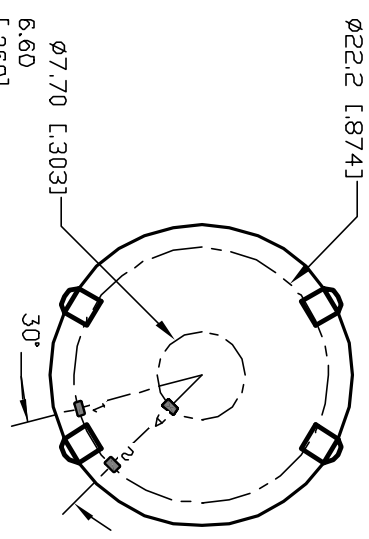
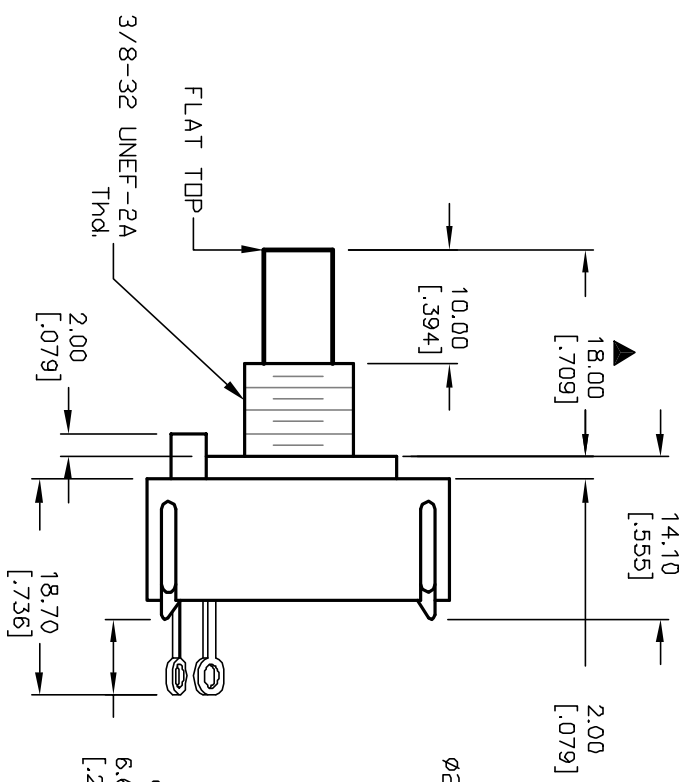
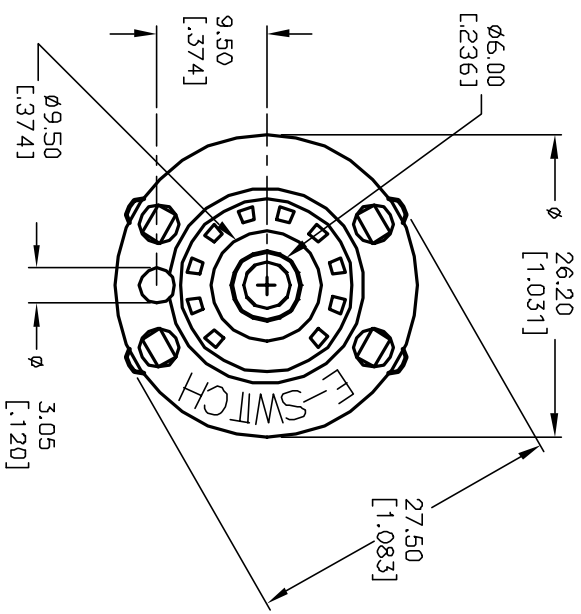
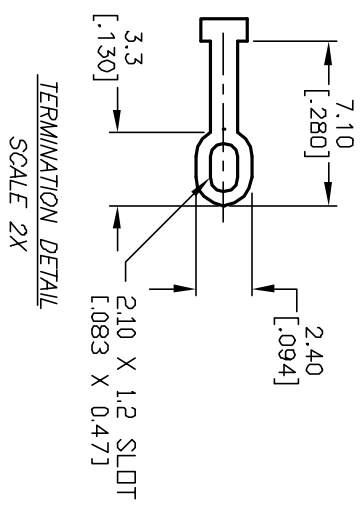

REV. A		12512		RELEASED FOR PRODUCTION		10/28/02		CJB	
REV.		ECN No.		DESCRIPTION		DATE		CHKD	
THE INFORMATION CONTAINED IN THIS DOCUMENT IS PROPRIETARY TO E-SWITCH AND IS NOT TO BE COPIED OR TRANSFERRED									
TITLE				KC-12-B-(10.0mm) 01-N-L-S					
SCALE				1.5:1					
DATE				10/28/02					
DR				CJB					
DWG				G527529					
REV				A					

E-SWITCH®