

CONTACT CONFIGURATION
TIMING (BBM) NON-SHORTING

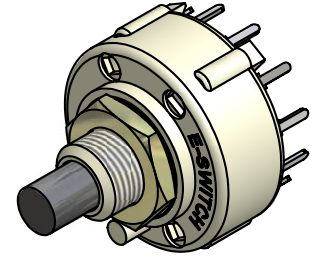

ISOMETRIC

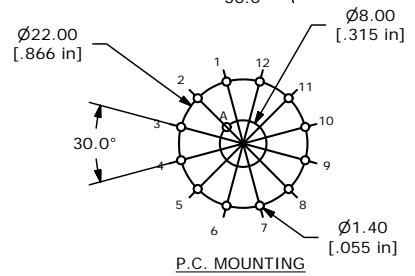
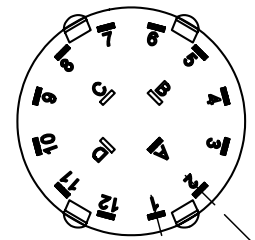
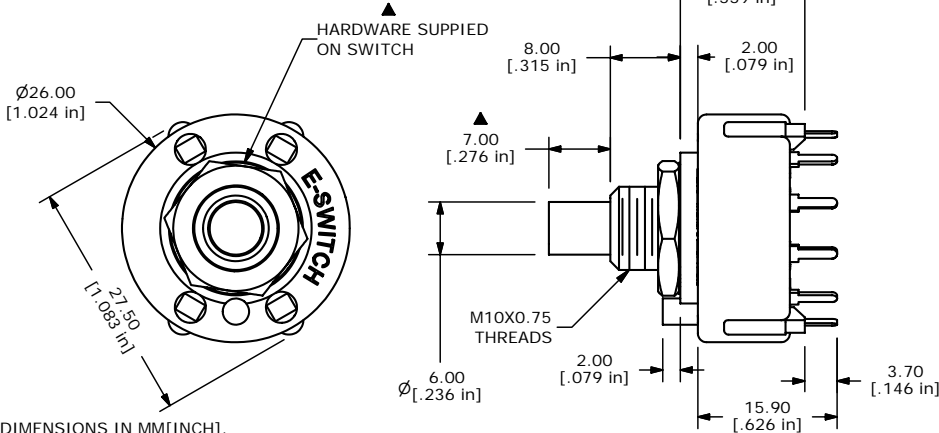

- NOTE:
1. ALL DIMENSIONS IN MM [INCH].
 2. GENERAL TOLERANCE: X.X=±0.4
X.XX=±0.25
 3. TERM. NOS. FOR REFERENCE ONLY.
 4. CONTACT MATERIAL: SILVER
 5. CONTACT RATING: 0.3A 125VAC
 6. OPERATING FORCE 800±300CM/STANDARD
 7. OPERATING TEMP: -30°C TO 85°C
 - ▲ 8. CIRCUIT SP: 12 POSITION 30° INDEX (NO-STOP)
 9. DIELECTRIC STRENGTH: 500VAC FOR 1 MIN..
 - ▲ 10. HARDWARE SUPPLIED ON SWITCH:
LOCKWASHER, HEXNUT, STOPRING
 11. ▲ DENOTES CRITICAL PARAMETER.
 12. 2002/95/EC (ROHS) COMPLIANT

E-SWITCH®

TITLE KC10B7.002NPS

A	15619	RELEASED FOR PRODUCTION	12/20/05	PH
REV	PCR NO	DESCRIPTION	DATE	BY

THE INFORMATION CONTAINED IN THIS DOCUMENT IS PROPRIETARY TO E-SWITCH AND IS NOT TO BE COPIED OR TRANSFERRED

SCALE	DATE	DR	DWG	REV
1.5:1	12/20/2005	PH	G510257	A