

- NOTES:
1. ALL DIMENSION IN MM [INCH]
 2. GENERAL TOLERANCE: X.X=±0.4
X.XX=±0.25
 3. TERM. NOS. FOR REF. ONLY
 4. CONTACT RATING SWITCHING: 150mA, 250V AC/DC
350mA, 110V AC/DC
 5. OPERATING FORCE: 425±100 CM/STANDARD
 6. OPERATING TEMP: -30° to 85°C
 7. CIRCUIT SP: 12 POSITIONS, 30° INDEX, NO STOPS
 8. DIELECTRIC STRENGTH: 1000V RMS min.@Sea Level
 9. ▲ DESIGNATE MAJOR FEATURE
 10. HARDWARE SUPPLIED ON SWITCH— SEE BELOW
LOCKWASHER, & HEX NUT

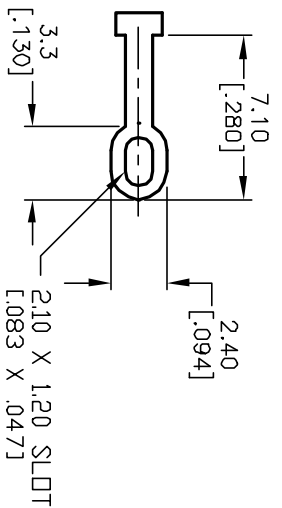
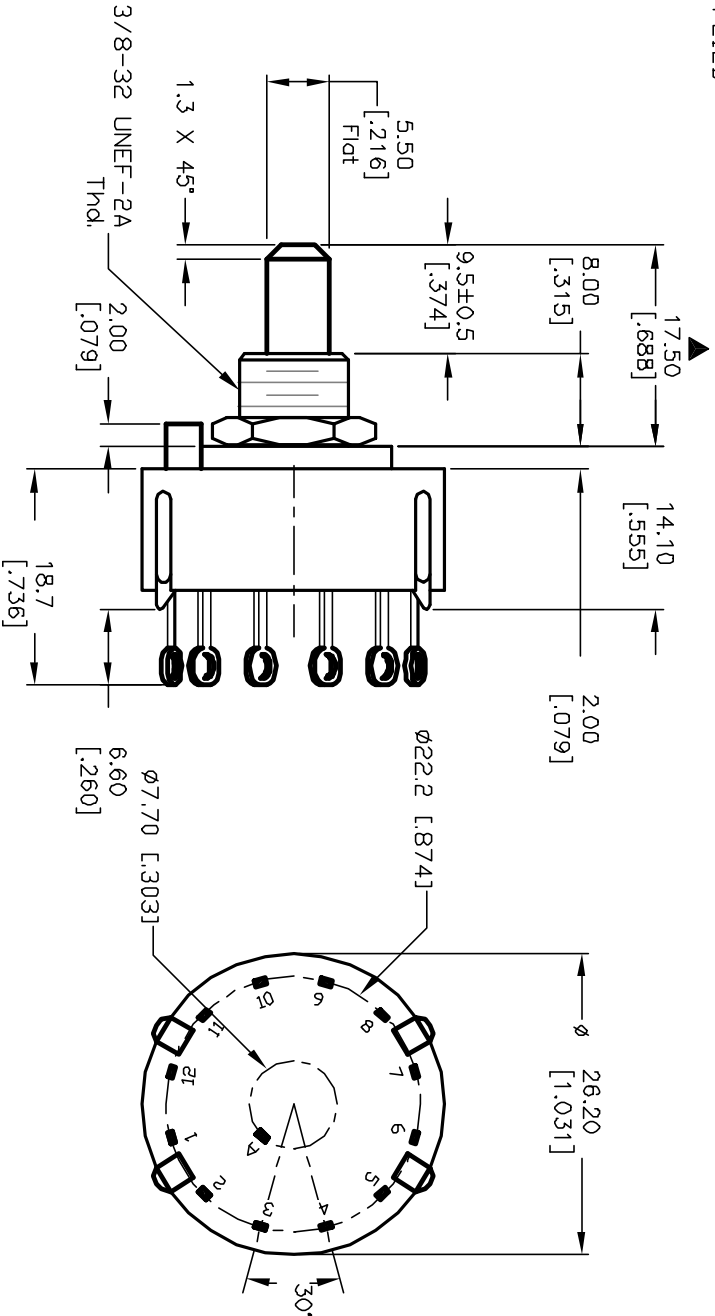
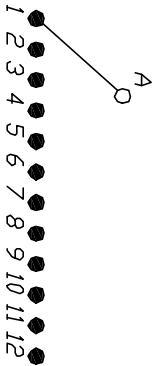
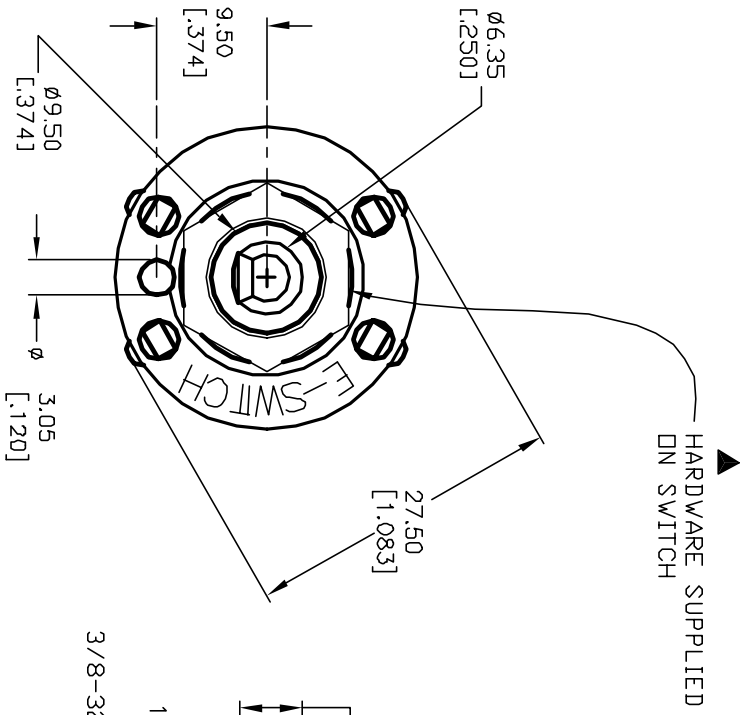

REV. A		12822		RELEASED FOR PRODUCTION		2/18/03		CJB	
REV.		ECN No.		DESCRIPTION		DATE		CHKD	
THE INFORMATION CONTAINED IN THIS DOCUMENT IS PROPRIETARY TO E-SWITCH AND IS NOT TO BE COPIED OR TRANSFERRED									
TITLE				KC-10-A-(9.5mm) 01-S-L-S					
SCALE				1.5:1					
DATE				2/18/03					
DR				CJB					
DWG				G527524					
REV				A					

E-SWITCH®