

SHEET OF

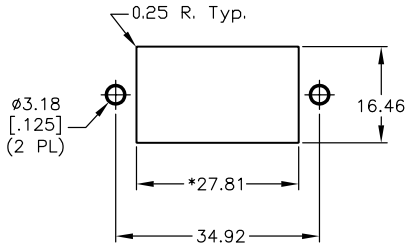

RECOMMENDED PANEL MOUNTING
N.T.S.

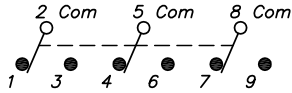

CIRCUIT: 3PDT

SWITCH FUNCTION		
PDS. 1	PDS. 2	PDS. 3
ON	OFF	ON
2-3,5-6,8-9	OPEN	2-1,5-4,8-7

NOTES:

- ALL DIMENSIONS IN MM [INCH]
- GENERAL TOLERANCE: X.X=±0.4;
X.XX=±0.25
- TERM. NOS. FOR REF. ONLY
- CONTACT RATING: 5A @120VAC or 28VDC;
2A @250VAC
- FIXED TERM/MOVING CONTACT:
COPPER ALLOY W/SILVER PLATE.
- ELECTRICAL LIFE:
50,000 make-and-break cycles at full load.
- INSULATION RESISTANCE: 1,000M ohm min.
- DIELECTRIC STRENGTH: 1,000 V RMS @sea level
- OPERATION TEMP.: -30°C to +85°C

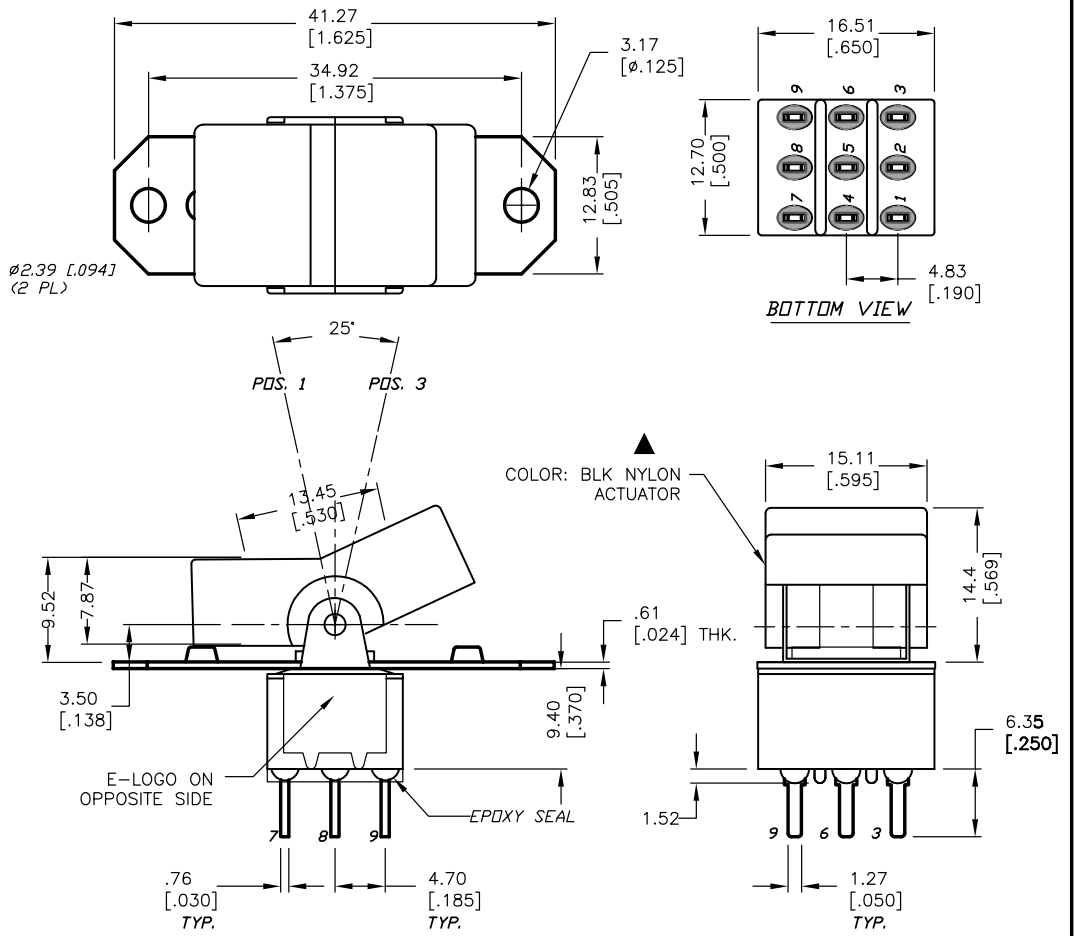

COLOR: BLK NYLON ACTUATOR

E-SWITCH®

TITLE					3003P3R3BLKM2QE				
SCALE	DATE	DR	DWG	REV					
2:1	6/8/04	AR	T333014	A					

THE INFORMATION CONTAINED IN THIS DOCUMENT IS PROPRIETARY TO E-SWITCH AND IS NOT TO BE COPIED OR TRANSFERRED