

RECOMMENDED PANEL MOUNTING

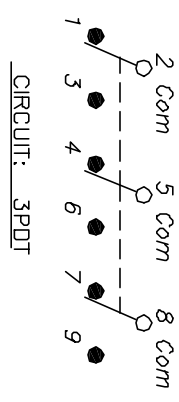

SWITCH FUNCTION		
POS. 1	POS. 2	POS. 3
DN	OFF	DN
2-3,5-6,8-9	DPEN	2-1,5-4,8-7

NOTES:

1. ALL DIMENSIONS IN MM. [INCH]
2. GENERAL TOLERANCE: X.X=±0.4; X.XX=±0.25
3. TERM. NOS. FOR REF. ONLY
4. CONTACT RATING: 5A @120VAC or 28VDC; 2A @250VAC
5. FIXED TERM/MOVING CONTACT: COPPER ALLOY W/SILVER PLATE.
6. ELECTRICAL LIFE: 50,000 make-and-break cycles at full load.
7. INSULATION RESISTANCE: 1,000 ohm min.
8. DIELECTRIC STRENGTH: 1,000 V RMS @sed level
9. OPERATION TEMP.: -30°C to +85°C

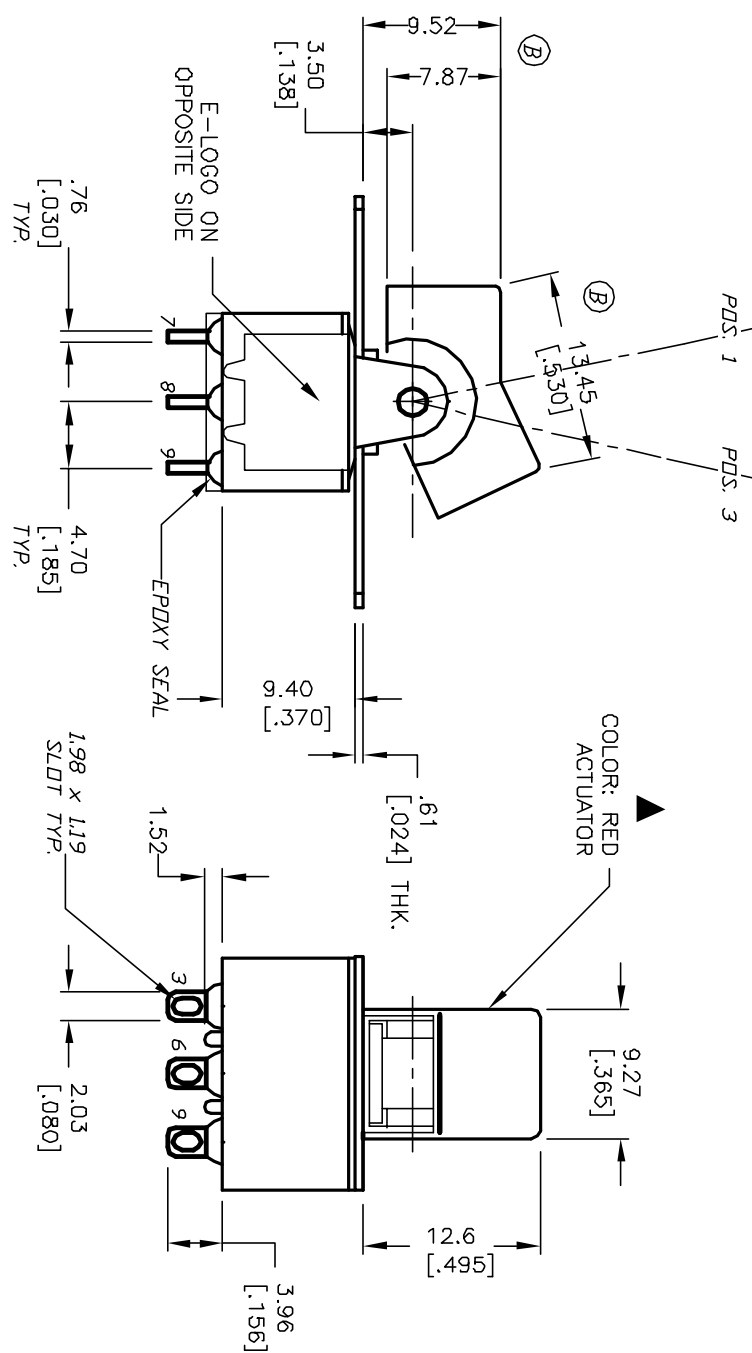

E-SWITCH®

300 3P3 R1 (RED) M1 Q E

REV.	ECN No.	DESCRIPTION	DATE	CHKD	SCALE	DATE	DR	DWG	REV
B	12048	REVISED ADD DIMENSIONS	4/9/02	CJB	2:1	4/9/02	CJB	T333003	B

THE INFORMATION CONTAINED IN THIS DOCUMENT IS PROPRIETARY TO E-SWITCH AND IS NOT TO BE COPIED OR TRANSFERRED