

RECOMMENDED PANEL MOUNTING

PANEL THICKNESS
 * DIMENSION IS 15.75/15.88
 FOR PANEL THICKNESS BETWEEN
 1.52mm TD 318mm

SWITCH FUNCTION			
PDS. 1	PDS. 2	PDS. 3	
DN	NONE	(DN)	
2-3,5-6	OPEN	2-1,5-4	

() = MOMENTARY

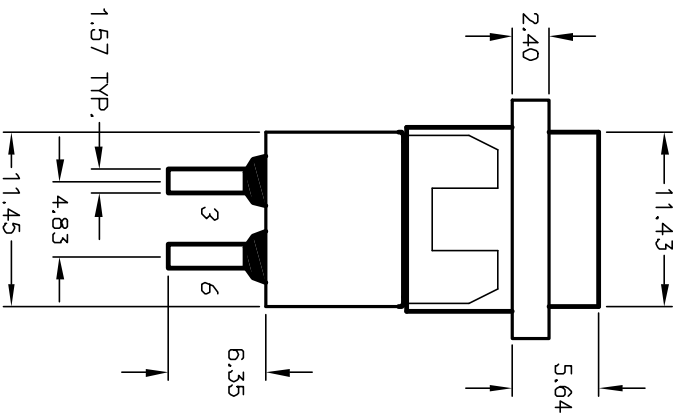
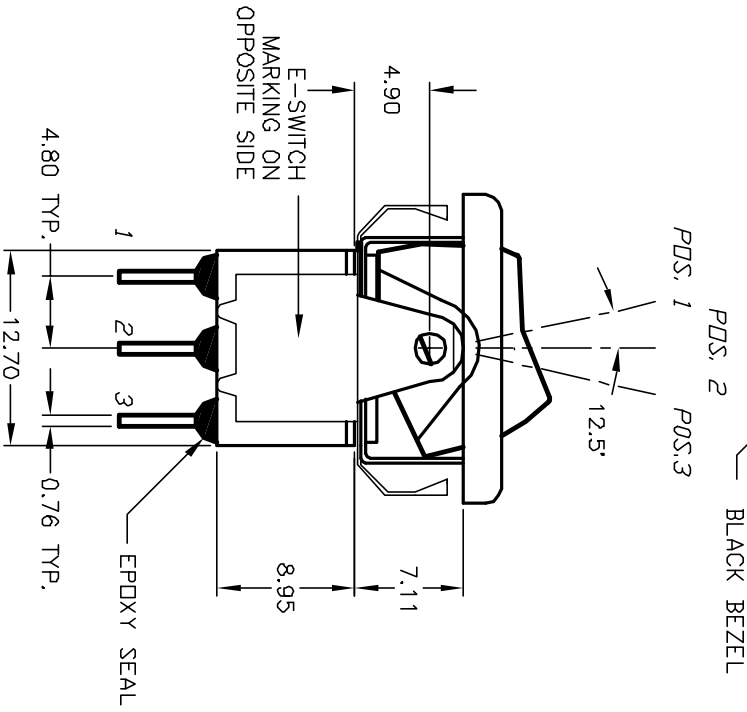

NOTES:

1. ALL DIMENSIONS IN MM [INCH]
2. GENERAL TOLERANCE: X.X=±0.4
X.XX=±0.25
3. TERM. NOS. FOR REF. ONLY
4. RATING: 5A @120VAC OR 2BVDC
2A @250VAC
5. MATERIAL: FIXED TERMINAL & MOVING CONTACT
Copper Alloy w/Silver Plate
6. CONTACT RESISTANCE: 10mILLI Ohms max initial
@2-4VDC, 100mA for AG & AU
7. ELECTRICAL LIFE: 50,000 make-and-break
cycles at full load.
8. INSULATION RESISTANCE: 1,000M ohm min.
9. DIELECTRIC STRENGTH: 1000V RMS @sea level
10. OPERATING TEMP.: -30°C to 85°C

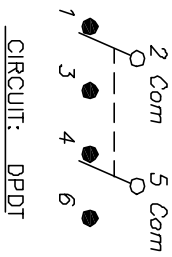

B		12120	DIMENSION WAS 20.10	5/6/02	CB	TITLE		300 DP-2 R6 BLK M3 Q E BLK	DR	CB	DWG	T322000	REV	B
A		12031	RELEASED FOR PRODUCTION	4/2/02	CB	SCALE		2:1	DATE	4/2/02				
REV.		ECN No.	DESCRIPTION	DATE	CHKD	THE INFORMATION CONTAINED IN THIS DOCUMENT IS PROPRIETARY TO E-SWITCH AND IS NOT TO BE COPIED OR TRANSMITTED								

E-SWITCH®