

RECOMMENDED P.C.B. LAYOUT

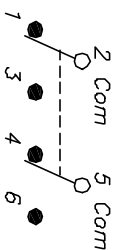

CIRCUIT: 2PDT

SWITCH FUNCTION		
POS. 1	POS. 2	POS. 3
DN	NONE	DN
2-3-5-6	OPEN	2-1-5-4

NOTES:

1. ALL DIMENSIONS IN MM
2. GENERAL TOLERANCE: X.X=±0.4
X.XX=±0.25
3. TERM. NOS. FOR REF. ONLY
4. RATING: 3A @120V AC or 28VDC;
1A @250V AC
5. FIXED TERMINAL/MOVING CONTACT:
COPPER ALLOY W/Silver plate
6. ELECTRICAL LIFE: 30,000 MAKE-AND-BREAK CYCLES
AT FULL LOAD.
7. INSULATION RESISTANCE: 1000M OHM TYPICAL
8. DIELECTRIC STRENGTH: 1,000 V RMS @SEA LEVEL
9. OPERATING TEMP.: -30°C to 85°C

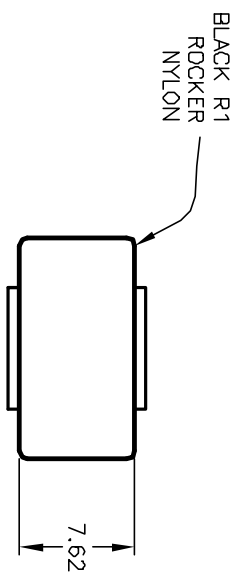

BLACK R1
ROCKER
NYLON

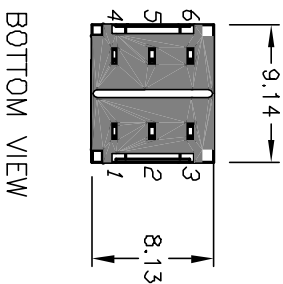
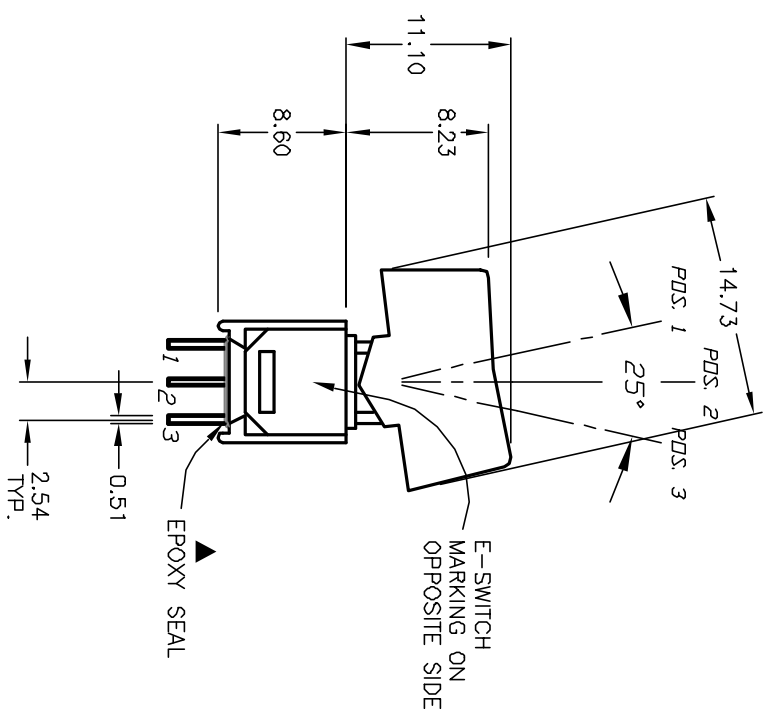

BOTTOM VIEW

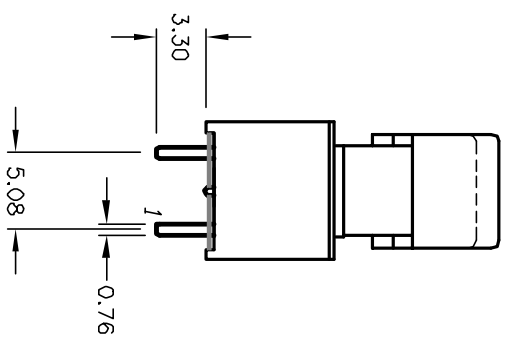

REV.	ECN NO.	DESCRIPTION	DATE	CHKD
B	12367	REVISED AND REDRAWN	9/20/02	CB

TITLE		SCALE	DATE	DR	DWG	REV
400 MDP-1 R1 (BLK) M2 QE		2:1	--	--	T421005	B

E-SWITCH®

THE INFORMATION CONTAINED IN THIS DOCUMENT IS PREPARED FOR E-SWITCH AND IS NOT TO BE COPIED OR TRANSMITTED