

SHEET OF

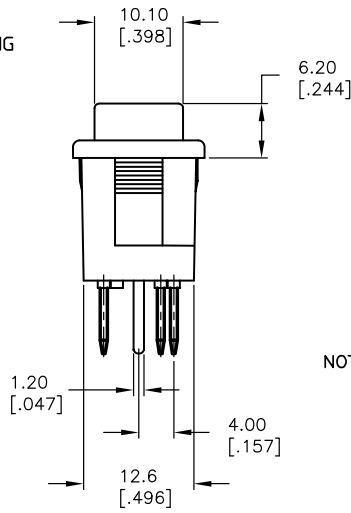
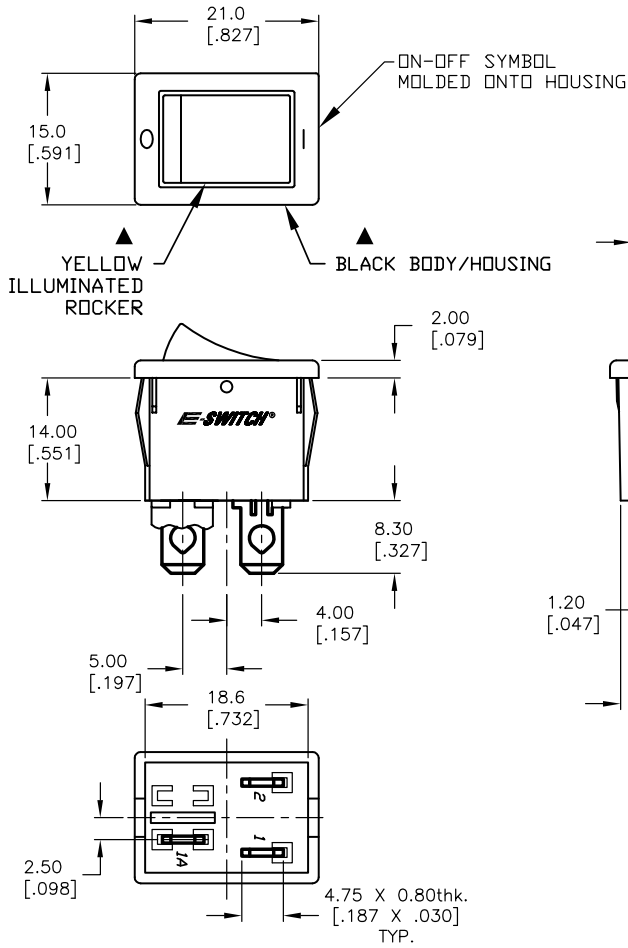

INCANDESCENT BULB

PARAMETERS	SYMBOL	MAX.	UNITS
LAMP VOLTAGE (AC/DC)	V	12	V
POWER DISSIPATION	P _D	2	Watts
CURRENT	I	100	mA

PANEL THICKNESS	X dimension
0.75-1.25 [.030-.049]	19.2-0.1 [.756]
1.25-2.0 [.049-.079]	19.4-0.1 [.764]
2.0-3.0 [.079-.118]	19.8-0.1 [.780]

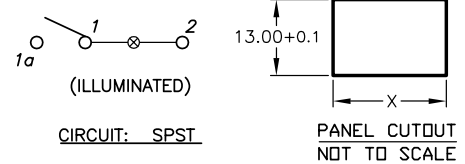

NOTES:

- ALL DIMENSIONS IN MM [INCH]
- GENERAL TOLERANCE: X.X=±0.4
X.XX=±0.25
- RATING:
6A @250VAC;9A @125VAC (UL, CSA, VDE)
4(1)A @250VAC
- LAMP VOLTAGE: 12VDC (INCANDESCENT BULB)
- MATERIAL:
CONTACT SURFACE: Coin Silver, Silver Plate
TERMINAL: Copper Alloy W/ Silver Plate.
- CONTACT RESISTANCE: 20mILLIOHMS TYP. INITIAL
- INSULATION RESISTANCE: 1000MegaOHMS
- DIELECTRIC STRENGTH:
>1500V RMS min. @SEA LEVEL
>3000V RMS @SEA LEVEL
- MECHANICAL LIFE: 50,000 CYCLES.
- ELECTRICAL LIFE: 10,000 CYCLES.

E-SWITCH®

TITLE	R1973ABLKYLEF3								
SCALE	1.5:1	DATE	11/26/03	DR	AR	DWG	M400201	REV	A

REV.	ECN No.	DESCRIPTION	DATE	CHKD
A	13625	RELEASED FOR PRODUCTION	11/26/03	AR

THE INFORMATION CONTAINED IN THIS DOCUMENT IS PROPRIETARY TO E-SWITCH AND IS NOT TO BE COPIED OR TRANSFERRED