

RECOMMENDED PANEL MOUNTING

PANEL THICKNESS	X ± 0.05
0.75-1.25	29.65
1.25-2.00	30.15
2.00-3.00	30.50

SWITCH FUNCTION		
POS. 1	POS. 2	POS. 3
ON	N/A	OFF
1-1a	NONE	OPEN

- NOTES:
- ALL DIMENSIONS IN MM [INCH]
  - GENERAL TOLERANCE: X.X=±0.4  
X.XX=±0.25
  - TERM. NOS. FOR REF. ONLY
  - RATING: 20A 125VAC, 16A 250VAC UL APPROVED  
16A 250VAC VDE APPROVED
  - MECHANICAL LIFE: > 30,000 CYCLES
  - ELECTRICAL LIFE: < 20mOHMS (INITIAL)
  - DIELECTRIC STRENGTH: > 1500V 1 min
  - LAMP VOLTAGE: 12VDC INCANDESCENT
  - OPERATING TEMPERATURE: TERMINAL SIDE: -20°C to 85°C  
ROCKER SIDE: -20°C to 55°C
  - FLAMABILITY: UL94 V-2
  - ▲ DENOTES CRITICAL PARAMETER.
  - 2002/95/EC (ROHS) COMPLIANT

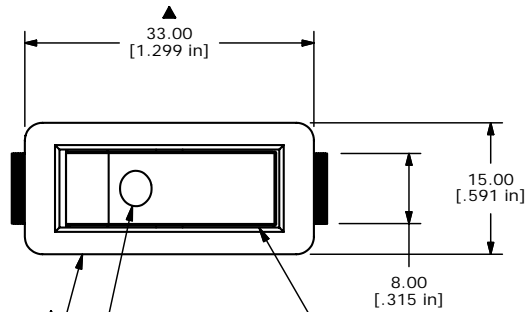

HOUSING COLOR: BLACK ▲ LAMP COLOR: RED ▲ ROCKER COLOR: BLACK ▲

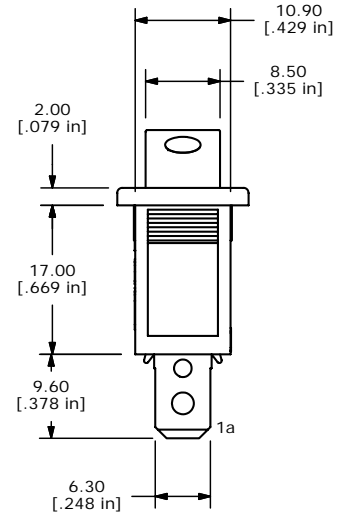
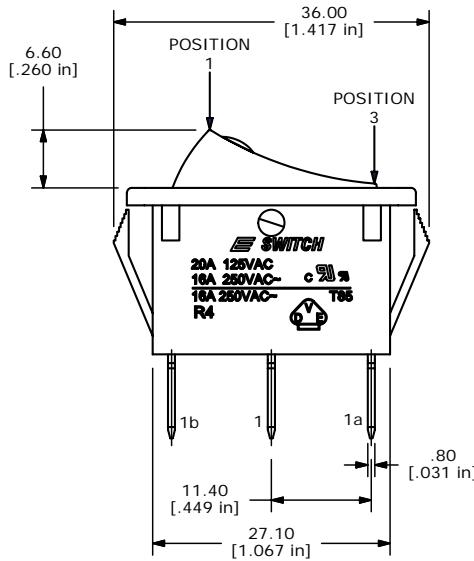
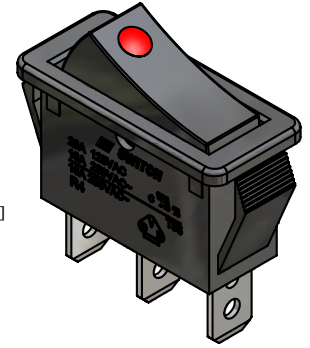

D	16014	UPDATE DRAWING TO NEW STANDARDS	5/9/06	CT
C	15832	REVISE AND REDRAWN	3/1/06	PH
REV	PCR NO	DESCRIPTION	DATE	BY

TITLE R4BBLKBLKREDEF3				
SCALE	DATE	DR	DWG	REV
1.5:1	3/1/2006	--	M040121	D

THE INFORMATION CONTAINED IN THIS DOCUMENT IS PROPRIETARY TO E-SWITCH AND IS NOT TO BE COPIED OR TRANSFERRED