

RECOMMENDED PANEL MOUNTING

PANEL THICKNESS	X ± 0.05
0.75-1.25	29.65
1.25-2.00	30.15
2.00-3.00	30.50

SWITCH FUNCTION		
POS. 1	POS. 2	POS. 3
ON	N/A	OFF
1-1a	NONE	OPEN

NOTES:

- ALL DIMENSIONS IN MM [INCH]
- GENERAL TOLERANCE: X.X=± 0.4  
X.XX=± 0.25
- TERM. NOS. FOR REF. ONLY
- RATING: 20A 125VAC, 16A 250VAC UL APPROVED  
16A 250VAC VDE APPROVED
- MECHANICAL LIFE: > 30,000 CYCLES
- ELECTRICAL LIFE: < 20mOHMS (INITIAL)
- DIELECTRIC STRENGTH: > 1500V 1 min
- OPERATING TEMPERATURE: TERMINAL SIDE: -20°C to 85°C  
ROCKER SIDE: -20°C to 55°C
- LAMP VOLTAGE: 12VDC INCANDESCENT
- FLAMABILITY: UL94 V-2
- ▲ DENOTES CRITICAL PARAMETER.
- 2002/95/EC (ROHS) COMPLIANT

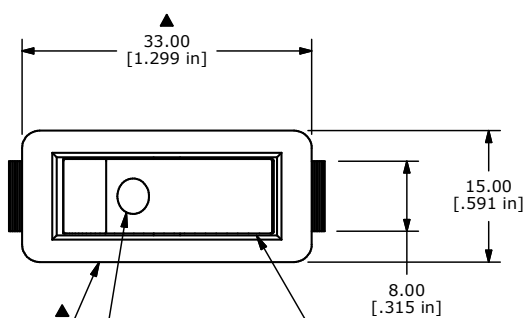

HOUSING COLOR: BLACK  
LENS COLOR: GREEN  
ROCKER COLOR: BLACK

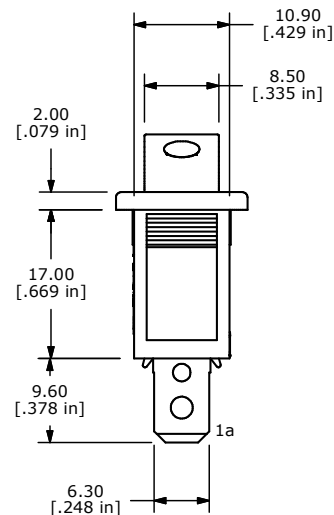
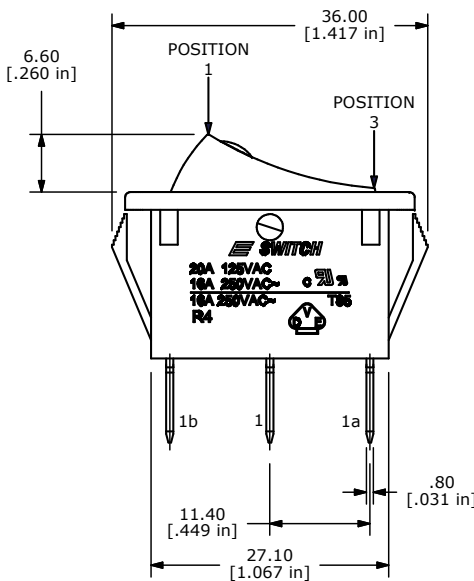
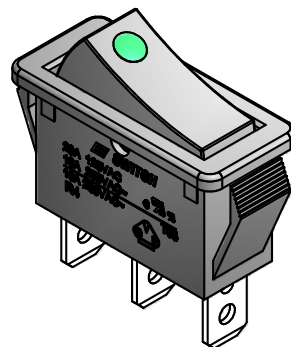

D	16014	UPDATE TO CURRENT STANDARDS	5/9/06	CT
C	15854	REVISE AND REDRAWN	3/9/06	PH
REV	PCR NO	DESCRIPTION	DATE	BY

TITLE R4BBLKBLKGRNEF3				
SCALE 1.5:1	DATE 3/9/2006	DR__	DWG M040125	REV D

THE INFORMATION CONTAINED IN THIS DOCUMENT IS PROPRIETARY TO E-SWITCH AND IS NOT TO BE COPIED OR TRANSFERRED