

IGBT Modules Sixpack

Short Circuit SOA Capability
Square RBSOA

Preliminary data

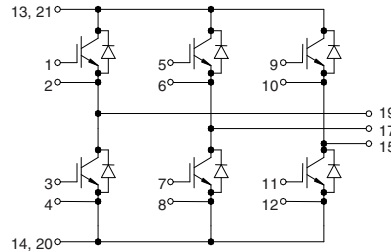

$$I_{C25} = 225 \text{ A}$$

$$V_{CES} = 600 \text{ V}$$

$$V_{CE(sat) \text{ typ.}} = 2.0 \text{ V}$$

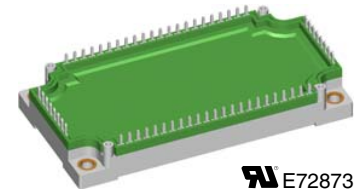

See outline drawing for pin arrangement

IGBTs			
Symbol	Conditions	Maximum Ratings	
V_{CES}	$T_{VJ} = 25^{\circ}\text{C to } 150^{\circ}\text{C}$	600	V
V_{GES}		± 20	V
I_{C25}	$T_C = 25^{\circ}\text{C}$	225	A
I_{C80}	$T_C = 80^{\circ}\text{C}$	155	A
RBSOA	$V_{GE} = \pm 15 \text{ V}; R_G = 1.5 \Omega; T_{VJ} = 125^{\circ}\text{C}$ Clamped inductive load; $L = 100 \mu\text{H}$	$I_{CM} = 400$ $V_{CEK} \leq V_{CES}$	A
t_{SC} (SCSOA)	$V_{CE} = V_{CES}; V_{GE} = \pm 15 \text{ V}; R_G = 1.5 \Omega; T_{VJ} = 125^{\circ}\text{C}$ non-repetitive	10	μs
P_{tot}	$T_C = 25^{\circ}\text{C}$	675	W

Features

- €NPT IGBT technology
- €low saturation voltage
- €low switching losses
- €switching frequency up to 30 kHz
- €square RBSOA, no latch up
- €high short circuit capability
- €positive temperature coefficient for easy paralleling
- €MOS input, voltage controlled
- €ultra fast free wheeling diodes
- €solderable pins for PCB mounting
- €package with copper base plate

Advantages

- €space savings
- €reduced protection circuits
- €package designed for wave soldering

Typical Applications

- €AC motor control
- €AC servo and robot drives
- €power supplies

Symbol	Conditions	Characteristic Values ($T_{VJ} = 25^{\circ}\text{C}$, unless otherwise specified)		
		min.	typ.	max.
$V_{CE(sat)}$	$I_C = 200 \text{ A}; V_{GE} = 15 \text{ V}; T_{VJ} = 25^{\circ}\text{C}$ $T_{VJ} = 125^{\circ}\text{C}$		2.0 2.3	V V
$V_{GE(th)}$	$I_C = 4 \text{ mA}; V_{GE} = V_{CE}$	4.5		6.5 V
I_{CES}	$V_{CE} = V_{CES}; V_{GE} = 0 \text{ V}; T_{VJ} = 25^{\circ}\text{C}$ $T_{VJ} = 125^{\circ}\text{C}$		1.5	1.8 mA mA
I_{GES}	$V_{CE} = 0 \text{ V}; V_{GE} = \pm 20 \text{ V}$			400 nA
$t_{d(on)}$ t_r $t_{d(off)}$ t_f E_{on} E_{off}	Inductive load, $T_{VJ} = 125^{\circ}\text{C}$ $V_{CE} = 300 \text{ V}; I_C = 200 \text{ A}$ $V_{GE} = \pm 15 \text{ V}; R_G = 1.5 \Omega$		180	ns
			50	ns
			300	ns
			40	ns
			4.6	mJ
			6.3	mJ
C_{ies}	$V_{CE} = 25 \text{ V}; V_{GE} = 0 \text{ V}; f = 1 \text{ MHz}$		9.0	nF
Q_{Gon}	$V_{CE} = 300 \text{ V}; V_{GE} = 15 \text{ V}; I_C = 200 \text{ A}$		670	nC
R_{thJC}	(per IGBT)			0.18 K/W

Diodes

Symbol	Conditions	Maximum Ratings	
I_{F25}	$T_C = 25^\circ\text{C}$	260	A
I_{F80}	$T_C = 80^\circ\text{C}$	165	A

Symbol	Conditions	Characteristic Values		
		min.	typ.	max.
V_F	$I_F = 200\text{ A}; V_{GE} = 0\text{ V}; T_{VJ} = 25^\circ\text{C}$ $T_{VJ} = 125^\circ\text{C}$	1.9	2.1	V
I_{RM} t_{tr}	$I_F = 120\text{ A}; di_F/dt = -1000\text{ A}/\mu\text{s}; T_{VJ} = 125^\circ\text{C}$ $V_R = 300\text{ V}; V_{GE} = 0\text{ V}$	56		A
		100		ns
R_{thJC}	(per diode)			0.3 K/W

Module

Symbol	Conditions	Maximum Ratings	
T_{VJ}	operating	-40...+125	$^\circ\text{C}$
T_{JM}		+150	$^\circ\text{C}$
T_{stg}		-40...+125	$^\circ\text{C}$
V_{ISOL}	$I_{ISOL} \leq 1\text{ mA}; 50/60\text{ Hz}$	2500	V~
M_d	Mounting torque (M5)	3 - 6	Nm

Symbol	Conditions	Characteristic Values		
		min.	typ.	max.
$R_{pin-chip}$			1.8	m Ω
d_S	Creepage distance on surface	10		mm
d_A	Strike distance in air	10		mm
R_{thCH}	with heatsink compound		0.01	K/W
Weight			300	g

Equivalent Circuits for Simulation

Conduction

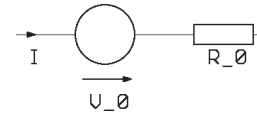

IGBT (typ. at $V_{GE} = 15\text{ V}; T_J = 125^\circ\text{C}$)
 $V_0 = 1.1\text{ V}; R_0 = 6\text{ m}\Omega$

Free wheeling Diode (typ. at $T_J = 125^\circ\text{C}$)
 $V_0 = 1.1\text{ V}; R_0 = 2\text{ m}\Omega$

Thermal Response

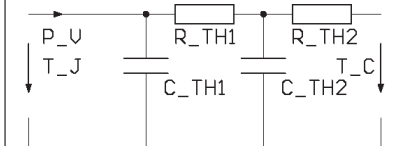

IGBT (typ.)

$C_{th1} = 0.397\text{ J/K}; R_{th1} = 0.131\text{ K/W}$
 $C_{th2} = 2.243\text{ J/K}; R_{th2} = 0.049\text{ K/W}$

Free wheeling Diode (typ.)

$C_{th1} = 0.281\text{ J/K}; R_{th1} = 0.236\text{ K/W}$
 $C_{th2} = 1.945\text{ J/K}; R_{th2} = 0.064\text{ K/W}$

Dimensions in mm (1 mm = 0.0394")

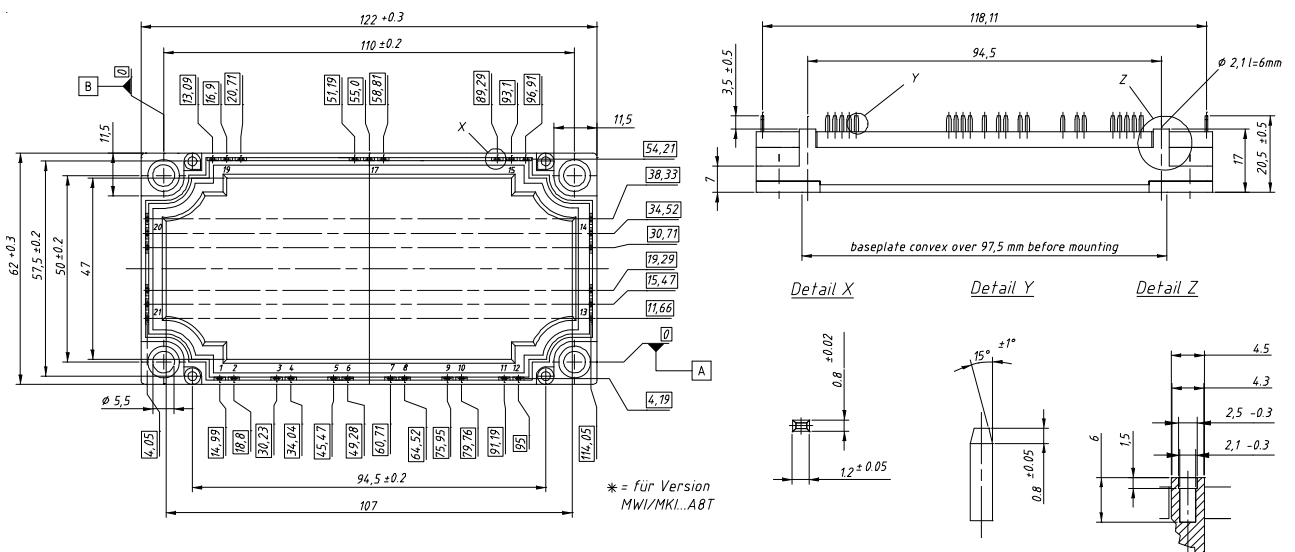

20070912a