

PANEL THICKNESS	X dimension
0.75-1.25 [0.30-0.49]	19.2- <i>a1</i> [7.56]
1.25-2.0 [0.49-0.79]	19.4- <i>a1</i> [7.64]
2.0-3.0 [0.79-1.18]	19.8- <i>a1</i> [7.80]

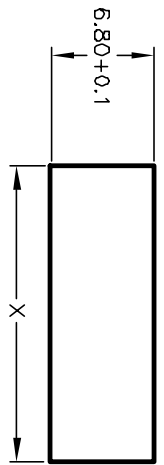

PANEL CUTOUT  
NOT TO SCALE

SWITCH FUNCTION	POS. 1	POS. 2
DN	DN	OFF
1-1a	OPEN	

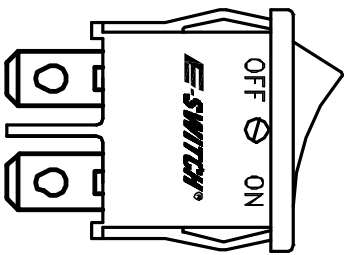
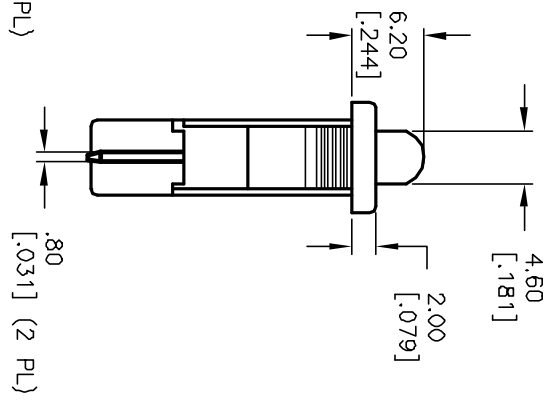
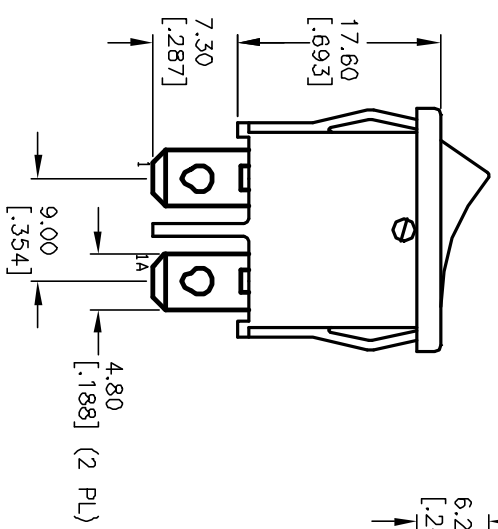
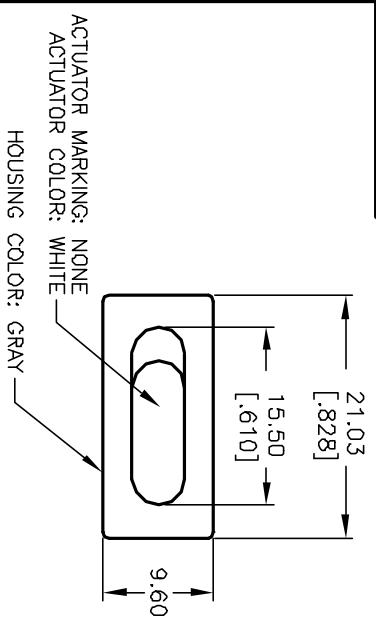

CIRCUIT: SPST

- NOTES:
1. ALL DIMENSIONS IN MM
  2. GENERAL TOLERANCE: X.X=±0.4; X.XX=±0.25
  3. TERMINAL NUMBERS FOR REF ONLY
  4. RATING: 4(1)A @250VAC, 6A @250VAC 10A @125VAC
  5. MATERIALS: TERMINALS: COPPER ALLOY W/SILVER PLATING CONTACTS: COIN SILVER
  6. MECHANICAL LIFE: >50,000 CYCLES
  7. ELECTRICAL LIFE: >10,000 CYCLES
  8. CONTACT RESISTANCE: < 20 MEGA-OHMS (INITIAL)
  9. INSULATION RESISTANCE: > 1000 MEGA-OHMS @ 500VDC
  10. DIELECTRIC STRENGTH: >1500VAC 1 MINUTE (INITIAL) >3000V BETWEEN POLES

**E-SWITCH®**

R6AGRYWHITEF

REV.	ECN No.	DESCRIPTION	DATE	CHKD
A	13004	RELEASED FOR PRODUCTION	4/7/03	AR

TITLE	SCALE	DATE	DR	DWG	REV
R6AGRYWHITEF	1.5:1	4/7/03	AR	M060308	A

THE INFORMATION CONTAINED IN THIS DOCUMENT IS PROPRIETARY TO E-SWITCH AND IS NOT TO BE COPIED OR TRANSFERRED