

RECOMMENDED PANEL MOUNTING

PANEL THICKNESS	X
0.75-1.25	19.2-19.3
1.25-2.00	19.3-19.4
2.00-3.00	19.5-19.6

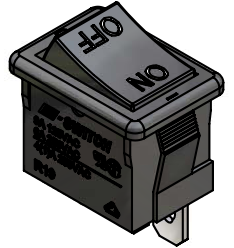

ISOMTRIC

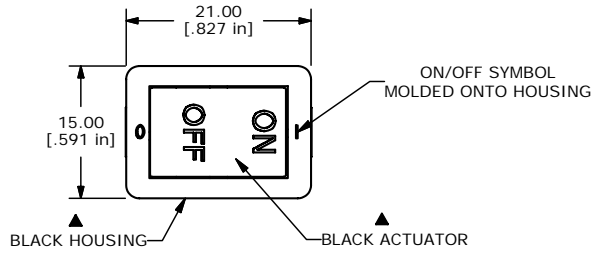
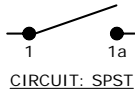
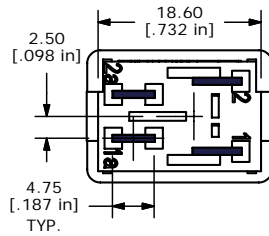
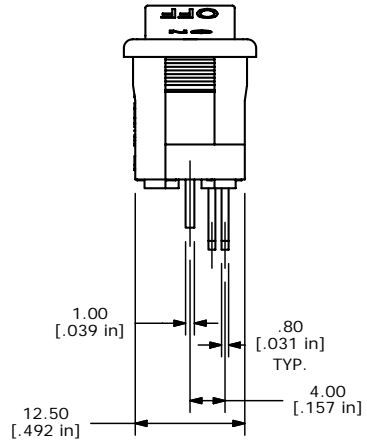
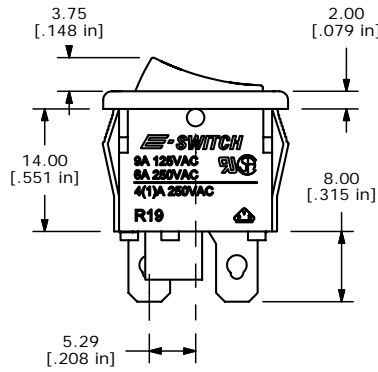

- NOTES:
1. ALL DIMENSIONS IN MM [INCH]
  2. GENERAL TOLERANCE: X.X=±0.4  
X.XX=±0.25
  3. RATING:  
6A @250VAC; 9A @125VAC (UL, CSA, VDE)
  4. MATERIAL:  
CONTACT SURFACE: COIN SILVER, SILVER PLATE  
TERMINAL: COPPER ALLOY W/SILVER PLATE.
  5. CONTACT RESISTANCE: 20 MILLI-OHMS TYP. INITIAL
  6. INSULATION RESISTANCE: 1000 MEGA-OHMS
  7. DIELECTRIC STRENGTH:  
>1500V RMS min. @SEA LEVEL
  8. MECHANICAL LIFE: 30,000 CYCLES.
  9. ELECTRICAL LIFE: 10,000 CYCLES
  10. ▲ DENOTES CRITICAL PARAMETER.
  11. 2002/95/EC (ROHS) COMPLIANT

**E-SWITCH®**

TITLE R1973ABLKBLKIF0

A	15979	NEW PART RELEASE	4/24/06	CT
REV	PCR NO	DESCRIPTION	DATE	BY

THE INFORMATION CONTAINED IN THIS DOCUMENT IS PROPRIETARY TO E-SWITCH AND IS NOT TO BE COPIED OR TRANSFERRED

SCALE	DATE	DR	DWG	REV
1.5:1	4/24/2006	CT	M400092	A