

RECOMMENDED PANEL MOUNTING

PANEL THICKNESS	X
0.75-1.25	19.2-19.3
1.25-2.00	19.3-19.4
2.00-3.00	19.5-19.6

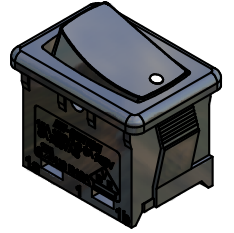

SWITCH FUNCTION		
POS. 1	POS. 2	POS. 3
ON	NONE	OFF
1-1a	N/A	OPEN

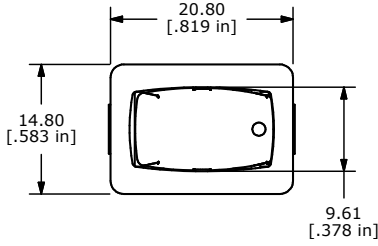
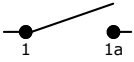

CIRCUIT: SPST

NOTES:

1. ALL DIMENSIONS IN MM [INCH]
2. GENERAL TOLERANCE: X.X=±0.4
X.XX=±0.25
3. TERM. NOS. FOR REF. ONLY
4. RATING: 8A @ 250VAC
15A @ 125VAC
5. CONTACT MATERIAL: SILVER
6. ELECTRICAL LIFE: 10,000 CYCLES MIN.
7. CONTACT RESISTANCE: <20 MILLI-OHMS INITIAL
8. DIELECTRIC STRENGTH: >1,500VAC FOR 1 MIN.
9. ▲ DENOTES CRITICAL PARAMETER.
10. 2002/95/EC (ROHS) COMPLIANT

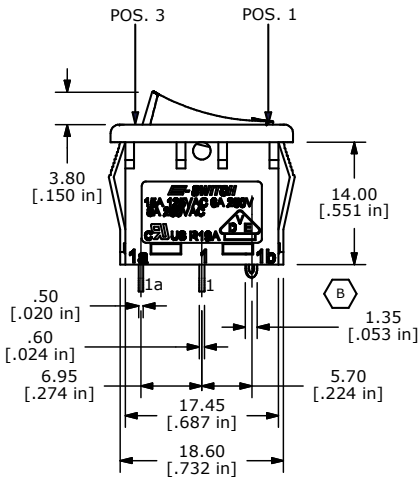

▲ ACTUATOR COLOR: BLACK

▲ HOUSING COLOR: BLACK

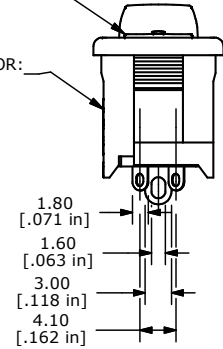

B	19359	UPDATE HOUSING	11/02/10	BMA	TITLE R1966ABLKBLKAS				
A	16413	RELEASED FOR PRODUCTION	9/7/06	BO					
REV	PCR NO	DESCRIPTION	DATE	BY	SCALE 1.5:1	DATE 9/7/2006	DR BO	DWG M300011	REV B
THE INFORMATION CONTAINED IN THIS DOCUMENT IS PROPRIETARY TO E-SWITCH AND IS NOT TO BE COPIED OR TRANSFERRED									