

PANEL THICKNESS	X dimension
0.75-1.25 [.030-.049]	19.2-0.1 [.756]
1.25-2.0 [.049-.079]	19.4-0.1 [.764]
2.0-3.0 [.079-.118]	19.8-0.1 [.780]

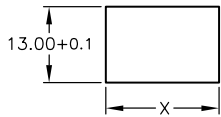

PANEL CUTOUT  
NOT TO SCALE

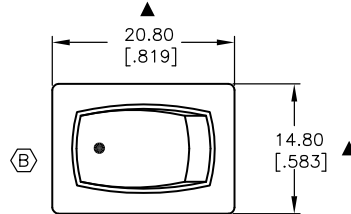

SWITCH FUNCTION	
PDS. 1	PDS. 2
ON	OFF
1-1a	OPEN

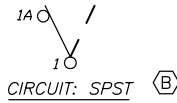

NOTES:

- ALL DIMENSIONS IN MM [INCH]
- GENERAL TOLERANCE: X.X=±0.4  
X.XX=±0.25
- TERMINAL NUMBERS FOR REF ONLY
- RATING:  
15A @125VAC; 8A @250V UL,VDE,CSA APPROVED  
6A @250VAC
- MATERIALS: (TERMINALS) SILVER PLATED COPPER  
(CONTACTS) COIN SILVER, SILVER PLATED.
- CONTACT RESISTANCE: <20 Mega
- ELECTRICAL LIFE: 10,000 cycles
- INSULATION RESISTANCE: >1000 Mega
- DIELECTRIC STRENGTH: >1500V 1 minute  
>3000V between Poles
- OPERATING TEMP. RANGE: -25°C to +85°C
- ▲ DENOTES CRITICAL PARAMETER.

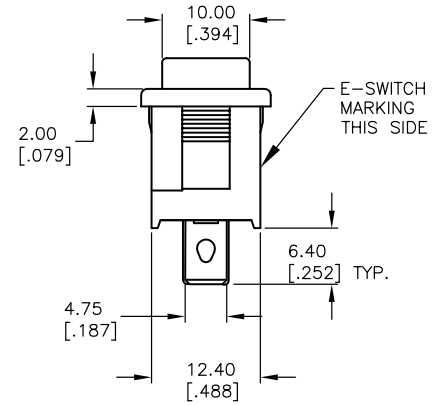
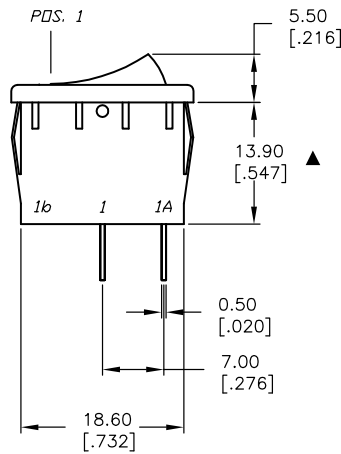

C	14397	CORRECT TITLE	10/12/04	AR
B	14358	GRAPHIC LOCATION, CIRCUIT	9/28/04	AR
A	13179	RELEASED FOR PRODUCTION	6/4/03	AR
REV.	ECN No.	DESCRIPTION	DATE	CHKD

THE INFORMATION CONTAINED IN THIS DOCUMENT  
IS PROPRIETARY TO E-SWITCH AND IS  
NOT TO BE COPIED OR TRANSFERRED

<b>E-SWITCH®</b>				
TITLE				
R1966ABLKBLKAG				
SCALE	DATE	DR	DWG	REV
1.5:1	6/4/03	AR	M300005	C