

DIMENSIONS IN INCHES (MILLIMETERS)  
DO NOT SCALE DRAWING... Drawing No. **GRS-2011C-2000**

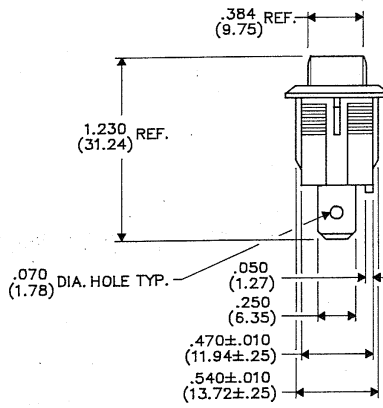
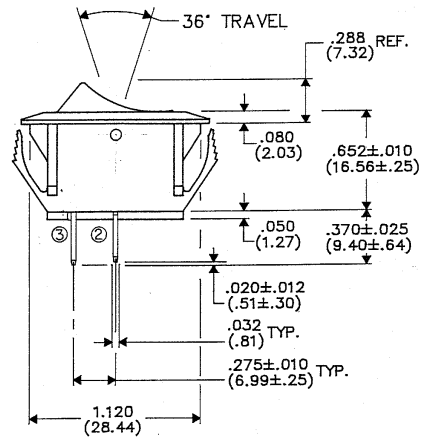
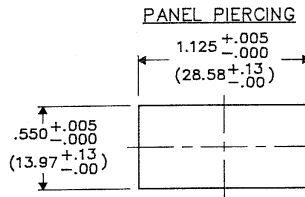
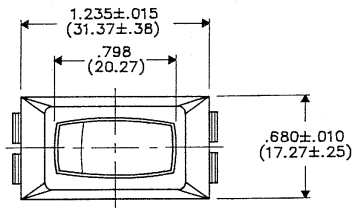

8-FORM-9  
REVISIONS  
RELEASED 4-11-90  
MAM 4-11-90  
SEP 21 1990

PDF File Made Made for: CW Ind. Drawn by: MAM 4-18-90 Checked by: <i>[Signature]</i> Approval: <i>[Signature]</i>	<b>CW INDUSTRIES</b> Southampton, Pa. 18966	Title ASSEMBLY DRAWING S.P.S.T. ROCKER SWITCH MOMENTARY NORMALLY CLOSED NON-POLARIZED 1.125" x .550" PANEL
	TOLERANCES UNLESS OTHERWISE SPECIFIED 2 Place decimal ±.010 METRIC 3 Place decimal ±.005 1 Place dec. ±.25 MM Angles . . . . . 1° 2 Place dec. ±.13 MM	
	Division SWITCH	Drawing No. <b>GRS-2011C-2000</b>

**MASTER**