

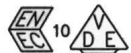

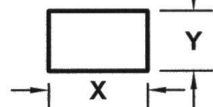

THIS INFORMATION IS CONFIDENTIAL AND PROPRIETARY TO CW INDUSTRIES INCORPORATED AND ITS AFFILIATES. IT MAY NOT BE DISCLOSED TO ANYONE, OTHER THAN CW INDUSTRIES PERSONNEL, WITHOUT WRITTEN AUTHORIZATION FROM CW INDUSTRIES INCORPORATED, SOUTHAMPTON, PENNSYLVANIA USA.

Rating	16A 125 VAC 1/3 HP 10A 250 VAC 1/2 HP		Mounting Hole		Circuit Diagram											
	10(4) A 250V ~					 SPST ON - OFF										
Contact Resistance	50m ohm max.	<table border="1"> <thead> <tr> <th>Thickness</th> <th>X</th> <th>Y</th> </tr> </thead> <tbody> <tr> <td>0.75 - 1.25</td> <td>19.2 - 0.1</td> <td>13.0 + 0.1</td> </tr> <tr> <td>1.25 - 2.00</td> <td>19.4 - 0.1</td> <td>13.0 + 0.1</td> </tr> <tr> <td>2.00 - 3.00</td> <td>19.8 - 0.1</td> <td>13.0 + 0.1</td> </tr> </tbody> </table>		Thickness	X		Y	0.75 - 1.25	19.2 - 0.1	13.0 + 0.1	1.25 - 2.00	19.4 - 0.1	13.0 + 0.1	2.00 - 3.00	19.8 - 0.1	13.0 + 0.1
Thickness	X	Y														
0.75 - 1.25	19.2 - 0.1	13.0 + 0.1														
1.25 - 2.00	19.4 - 0.1	13.0 + 0.1														
2.00 - 3.00	19.8 - 0.1	13.0 + 0.1														
Insulation Resistance	DC 500V 100M ohm min.															
Dielectric Strength	AC 1500V 1 minute															
Operating Temperature	-25°C ~ 85°C															

BASE COLOR: Black
 BUTTON COLOR: Black
 PRINTED: White, hot stamping

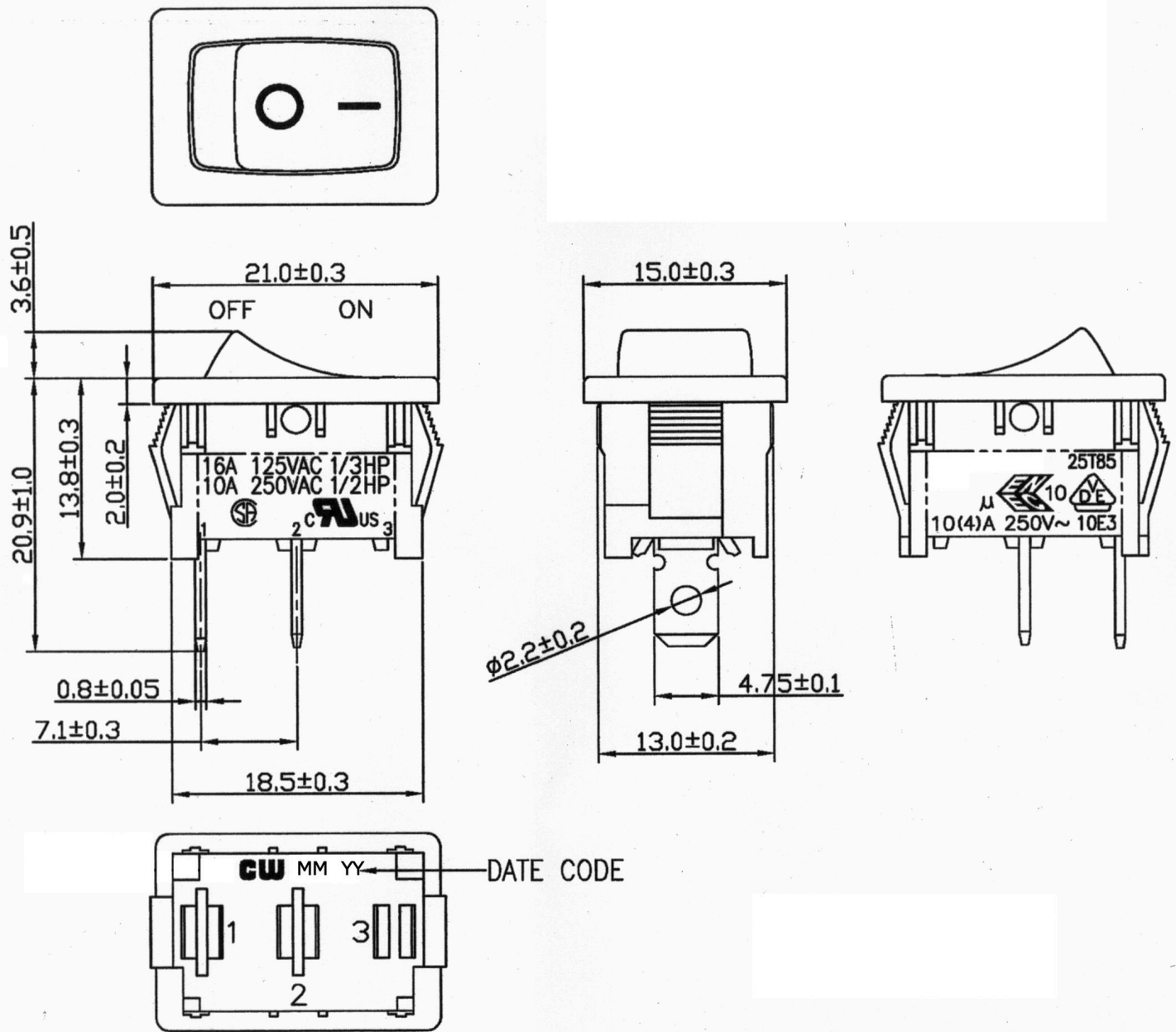

RoHS Compliant

 CW INDUSTRIES Southampton, Pa. 18966 Tel 215.355.7080/www.cwind.com	Date Drawn: 12/22/09	Rev. 0	Unit: mm	Checked By: G. Guld
	Title: ROCKER SWITCH		CW P/N: GRB066A02BB2	