

SHEET OF

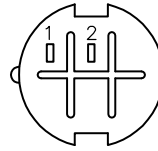

BOTTOM VIEW

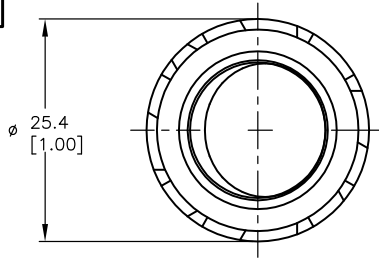
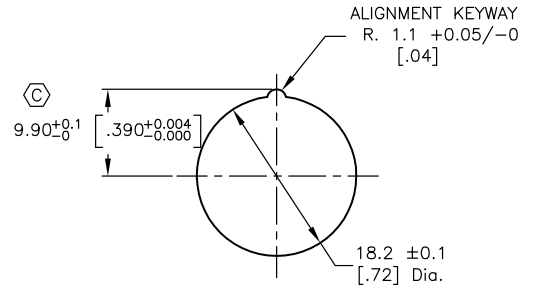

**RECOMMEND PANEL MOUNTING**  
6MM PANEL THICKNESS MAX.

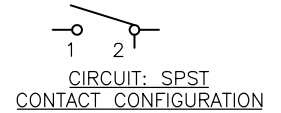
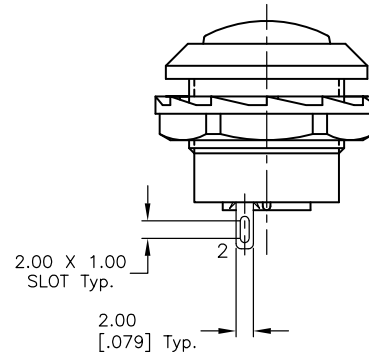
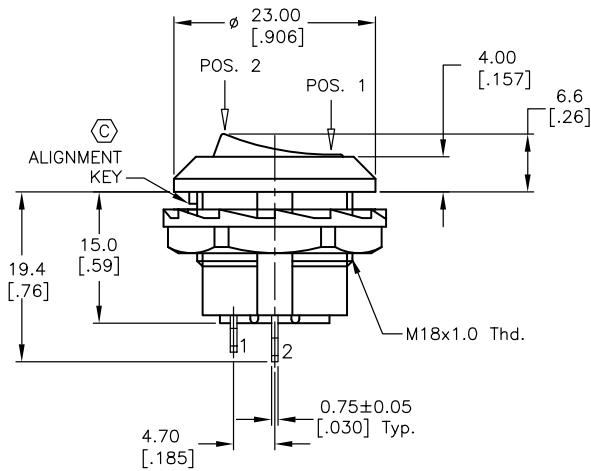

NOTES:

1. ALL DIMENSIONS IN MM [INCH]
2. GENERAL TOLERANCE: X.X=±0.4  
X.XX=±0.25
3. TERM. NOS. FOR REF. ONLY
4. RATING: 10A @125V, 6A @250VAC UL, CUL APPROVED
5. CONTACT RESISTANCE: 50m ohm Max.
6. INSULATION RESISTANCE: DC 500V 100m ohm Min.
7. DIELECTRIC STRENGTH: AC 1500V 1 minute.
8. OPERATING TEMPERATURE: 0°C TO +65°C

SWITCH FUNCTION	
POS. 1	POS. 2
ON	OFF
1-2	OPEN

C	13812	ADD NOTES, CHANGE DIM, TITLE	3/1/04	AR
B	13108	ORIENTATION POST, BOTTOM VIEW	5/6/03	AR
A	11996	RELEASED FOR PRODUCTION	3/12/02	CB
REV.	ECN No.	DESCRIPTION	DATE	CHKD

THE INFORMATION CONTAINED IN THIS DOCUMENT IS PROPRIETARY TO E-SWITCH AND IS NOT TO BE COPIED OR TRANSFERRED

<b>E-SWITCH®</b>				
TITLE RR3130ABLKBLKES				
SCALE	DATE	DR	DWG	REV
1.5:1	3/12/02	CB	F130415	C