

WB2 Series

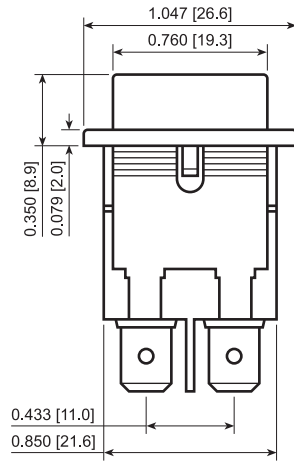

Panel Cutout

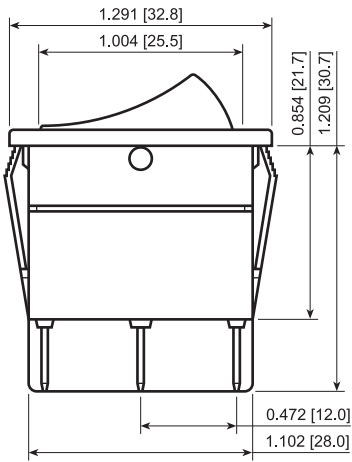
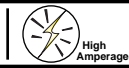
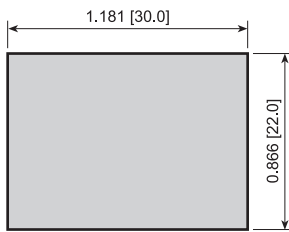

FEATURES:

- High Ratings with UL and TUV Approvals
- Industry Standard 22mm x 30mm Cutout
- Internal Dust and Water Protection to IP55

SPECIFICATIONS:

RATING: MAINTAINED SWITCHES:

- 20A 125VAC [cULus]
- 20A 250VAC [cULus]
- 2HP 125/250VAC [cULus]
- 22(14)A 250V~ 5E4 T85 [European]

MOMENTARY SWITCHES:

- 20A 125VAC T85 [cULus]
- 20A 250VAC T85 [cULus]
- 1.5HP 125/250VAC [cULus]
- 18(10)A 250V~ 5E4 T85 [European]

TEMPERATURE: -20°C to 65°C Min.

CONTACT RESISTANCE: 50mΩ Max.

INSULATION RESISTANCE: 500MΩ Min. at 500VDC

DIELECTRIC STRENGTH: 1,500VAC for 1 Minute

INGRESS PROTECTION: IP55 Standard

MATERIALS:

Body: Polyamide 6/6

ACTUATOR: Polyamide 6/6

MOUNTING EARS: Polyamide 6/6

RUBBER SEAL: Ethylene Propylene

CONTACTS: Silver Alloy

TERMINALS: Silver Plated Brass



WB242D1121



WB246D1100

SPECIFICATIONS SUBJECT TO CHANGE WITHOUT NOTICE

Series	Terminal	Function	Rating	Body Color	Actuator Color	Marking Color	Marking Type
WB2	4 - 6.3mm Tabs	1 Pole: D - (On)-Off-(On) 2 Pole: 2 - Off-On G - On-On E - Off-(On) H - On-(On) 6 - On-Off-On K - (On)-Off-(On)	D - 20A 125VAC	1 - Black 2 - White	1 - Black 2 - White 9 - Red	0 - None 1 - Black 2 - White	0 - None 1 - I/O Vert. 2 - ON/OFF/ON Vert. 3 - ON/OFF Vert. 4 - ON/OFF Horiz. 9 - I/O/II Horiz. S - I/O/II Vert. R - I/O Horiz.

Custom Colors and Markings Available Upon Request

EXAMPLE PART NUMBERS:

- WB242D1100** 2P Off-On
Black Body/Actuator, No Marking
- WB242D1121** 2P Off-On
Black Body/Actuator, I/O Vert.
- WB246D1100** 2P On-Off-On
Black Body/Actuator, No Marking
- WB246D112S** 2P On-Off-On
Black Body/Actuator, I/O/II Vert.
- WB24ED1121** 2P Off-(On)
Black Body/Actuator, No Marking
- WB24GD1100** 2P On-On
Black Body/Actuator, No Marking
- WB24KD1100** 2P (On)-Off-(On)
Black Body/Actuator, No Marking

