

WATERPROOF SINGLE-POLE ROCKER SWITCH

KC Series

Features

- Enclosed switch complying to IP56
- Lighted and non-lighted versions
- Multiple terminal options
- Mechanical life: 100,000 cycles
- DC electrical life: 6,000 cycles

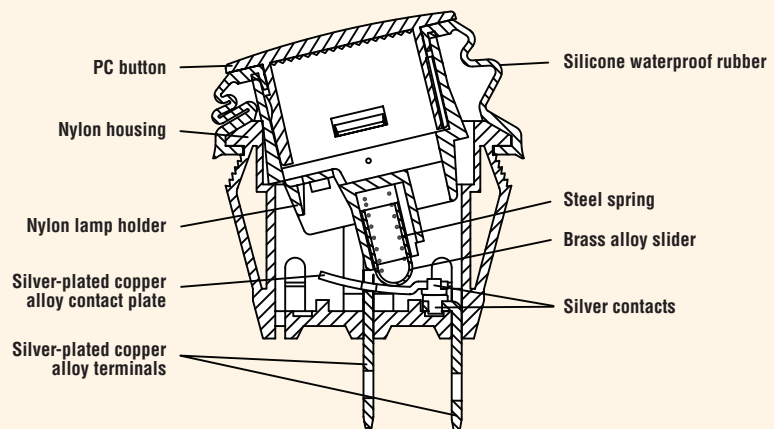

Electrical Ratings

Switch Series	VDC	EN61058 Rating	UL1054 Rating	Electrical Life at Rated Load	
				According to VDE (Min. Operations)	According to UL (Min. Operations)
KC	20A 14VDC; 10A 28VDC	10(4)A 250V	16A 125VAC; 10A 250VAC	10,000	6,000

Specifications

Electrical

Dielectric Strength:	1500VAC for 1 minute
Insulation Resistance:	10 ⁸ ohms min at 500VDC
Initial Contact Resistance:	0.050 ohms max
Temperature Rating:	-25°C to +85°C

Materials

Actuator:	Polycarbonate 94V-2
Housing:	Nylon 66 94V-2
Spring:	Stainless Wire
Contacts:	Silver Alloy
Movable Arm:	Silver-plated Copper Alloy
Terminals:	Silver-plated Copper Alloy
Waterproof Rubber:	Silicone



Dimensions inches (mm)

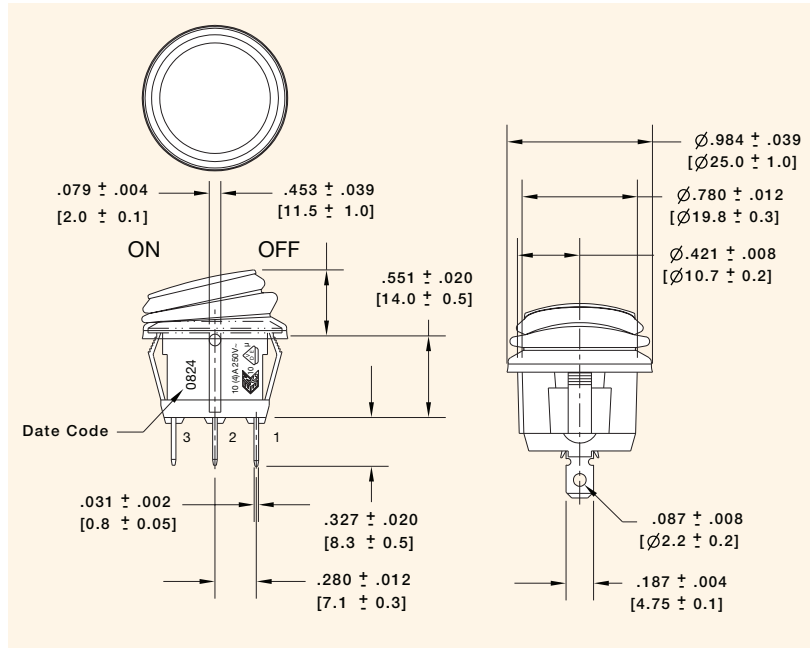

Panel Cut-Out Dimensions for Panel Thickness inches (mm)

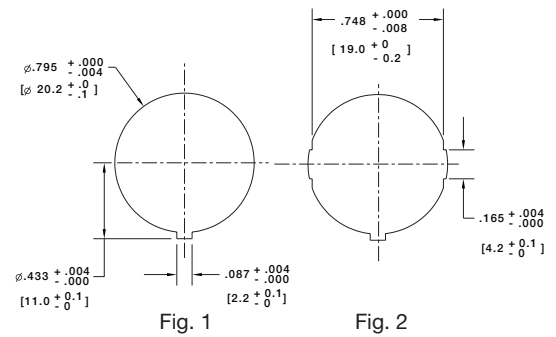

Mounting Holes	
Fig.	Panel Thickness
1	.059 to .098 (1.5 to 2.5)
2	.028 to .098 (0.7 to 2.5)

Examples of Common Part Numbers and Descriptions inches (mm)

Part Number	Circuitry	Switch Function	Terminal Type	Actuator/Housing Color	Legend Marking
KCA2ANA1BBB		On - Off	0.187 (4.75) Quick Connect	Black/Black	
KCA2ALA2RBB		On - Off (Illuminated)	0.187 (4.75) Quick Connect	Red/Black (Red Lens)	

Ordering Information

Series	Code	Circuitry	Code	Switch Function	Code	Terminal Type	Code	Actuator Color	Code	Housing Color	Code	Actuator Marking
KC	A	2	A	A	N	A	1	B	B	B	B	B
		Single-Pole		On - Off		0.187 (4.75) Quick Connect	A	Amber		Black	B	Blank
						PC Through Hole Straight	P	Black			C	•
						Solder (Round) 0.173 (4.4) Dia	R	Green			D	O -
								Blue			E	O
								Red			F	I I
											G	- =
											J	Z O O