

RECOMMENDED P.C.B. LAYOUT

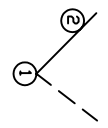

CIRCUIT: SPST

NOTES:

1. ALL DIMENSIONS IN MM
2. GENERAL TOLERANCE: X.X=±0.4
X.XX=±0.25
3. TERMINAL NO.S FOR REF ONLY.
4. RATING: AC 250V 5A/80A, TV-5
5. CONTACT RESISTANCE: 100m Ohms MAX. (AT DC 5V@1A)
6. DIELECTRIC STRENGTH: AC 1000V
7. OPERATING FORCE: 350±100gf
8. TRAVEL: FULL STROKE: 3.5±0.5/-0mm
LOCK STROKE: 2.5±0.5mm

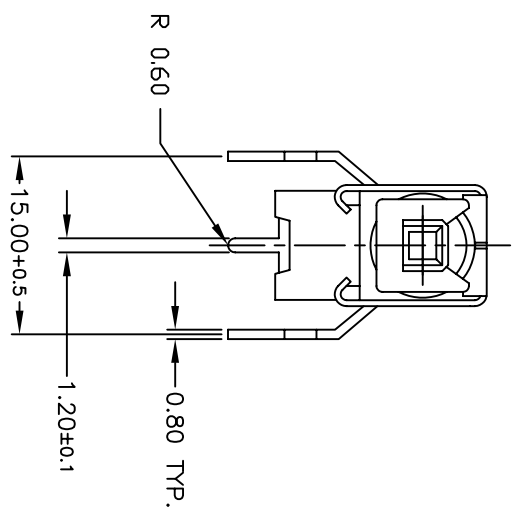
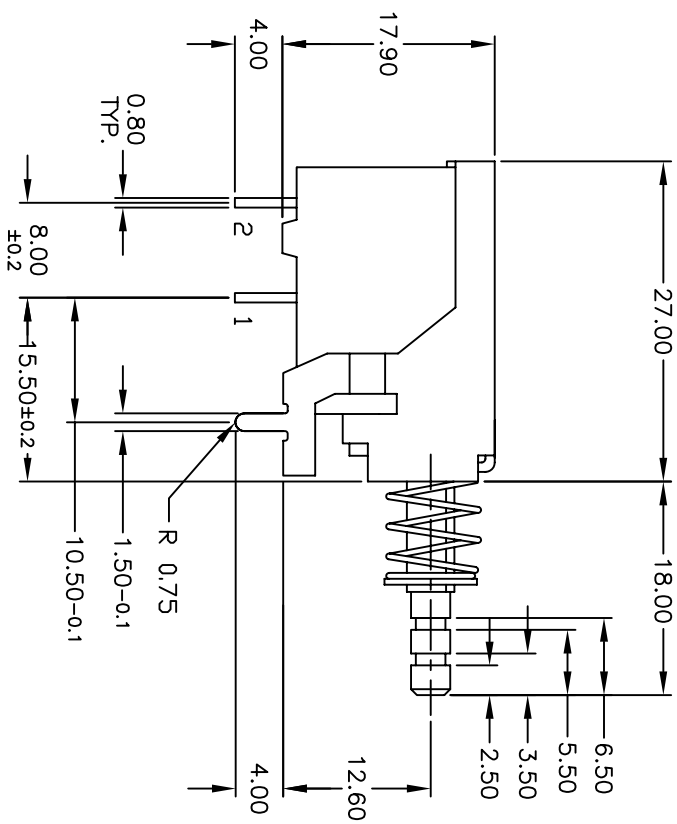

E-SWITCH®

C	15746	EDIT PC LAYOUT	2/8/06	PH
B	11208	REVISED AND REDRAWN	1/31/01	CJB
REV.	ECN NO.	DESCRIPTION	DATE	CHKD

TITLE		DATE		DR	DWG	REV
P197 EE PD		1/31/01		CJB	P030055	C
SCALE	1.5:1	DATE	1/31/01	DR	CJB	DWG
THE INFORMATION CONTAINED IN THIS DOCUMENT IS PROPRIETARY TO E-SWITCH AND IS NOT TO BE COPIED OR TRANSFERRED						