

RECOMMENDED P.C.B. LAYOUT

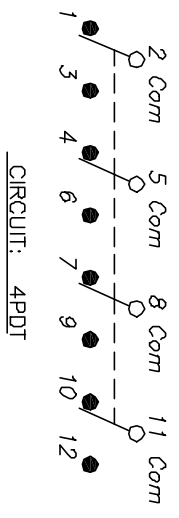

CIRCUIT: 4PDT

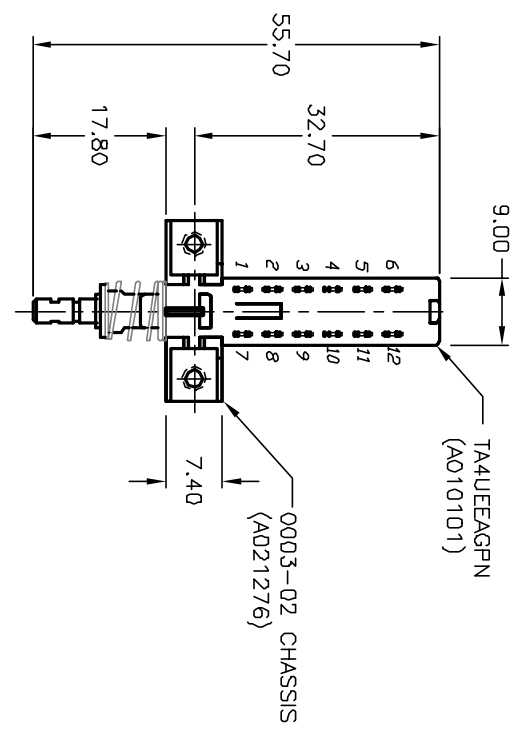
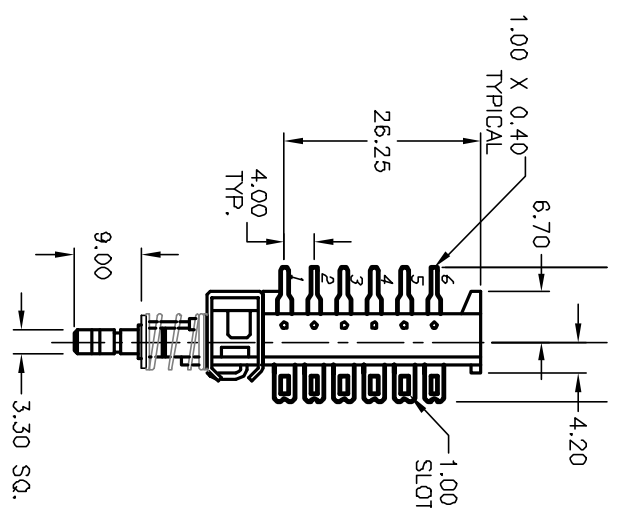
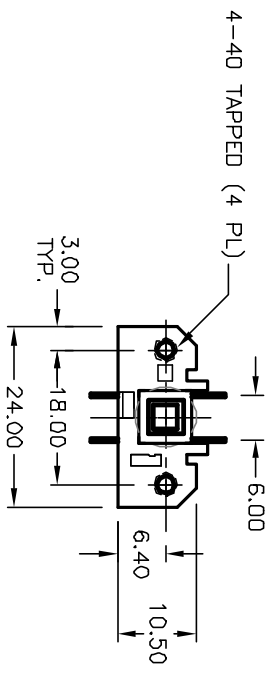

- NOTES:
1. ALL DIMENSIONS IN MM
 2. GENERAL TOLERANCE: X.X=±0.4
X.XX=±0.25
 3. TERM. NOS. FOR REF. ONLY
 4. RATING: 0.5A @100VAC, 0.2A @250VAC, 1A @25VDC
 5. OPERATING FORCE: <700 GRAMS
 6. CONTACT RESISTANCE: 30 MILL-OHM TYPICAL
 7. DIELECTRIC STRENGTH: 1,500 V RMS min.
 8. ELECTRICAL LIFE: 100,000 TYP. CYCLES
 9. OPERATING TEMP.: -20°C to 70°C

REV.	ECN NO.	DESCRIPTION	DATE	CHKD
A	11865	RELEASED FOR PRODUCTION	2/24/03	CJB

TITLE	SCALE	DATE	DR	DWG	REV
IXTA 0003-02 (/) 4U EE A AG PN TAPPED 4-40 T&F / F& B	1:1	--	--	XA0878B	A

