

ISOMETRIC

PARTS LIST			
ITEM	QTY	PART NUMBER	DESCRIPTION
1	1	F040024	D16EET13
2	1	F050205	WHITE TRANSPARENT RECT. CONCAVE
3	1	F050407	50-004-07 60VAC/DC INCANDESCENT

PANEL MOUNTING

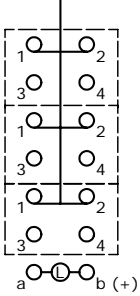

CONTACT CONFIGURATION

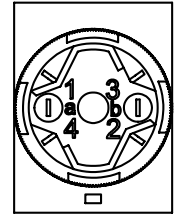
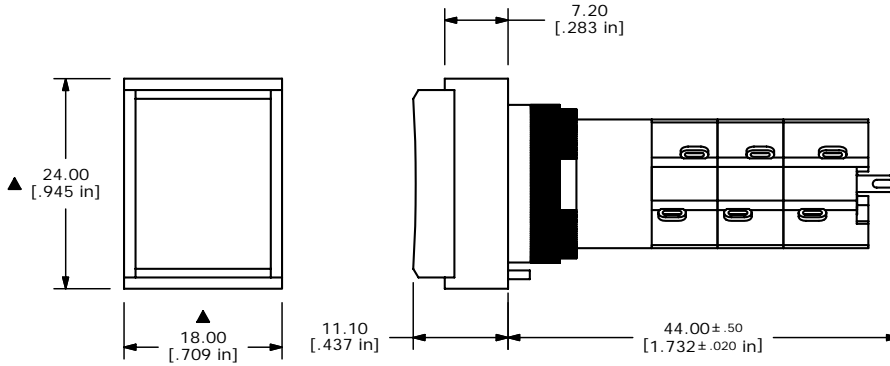

NOTE:

1. ALL DIMENSIONS IN MM [INCH]
2. GENERAL TOLERANCE: X.X=±0.4
X.XX=±0.25
3. TERMINAL NUMBERS FOR REF ONLY
4. MECHANICAL LIFE: 2,000,000 OPERATIONS
5. INSULATION RESISTANCE: 1,000 MEG-OHM MIN.
6. OPERATING TEMP.: -25°C to 55°C
- ▲ 7. LAMP VOLTAGE: INCANDESCENT 60V AC/DC 20mA
8. ▲ DENOTES CRITICAL PARAMETER.



B	16541	REMOVED POWER BUTTON, ADDED TABLE	10/17/2006	TN
A	16524	RELEASED FOR PRODUCTION	10/13/2006	TN
REV	PCR NO	DESCRIPTION	DATE	BY

TITLE D16EET13EWHT				
SCALE 1.5:1	DATE 10/13/2006	DR TN	DWG XF0690P	REV B

THE INFORMATION CONTAINED IN THIS DOCUMENT IS PROPRIETARY TO E-SWITCH AND IS NOT TO BE COPIED OR TRANSFERRED