

RECOMMENDED P.C.B. LAYOUT

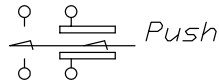

CIRCUIT: DPST

CONTACT CONFIGURATION

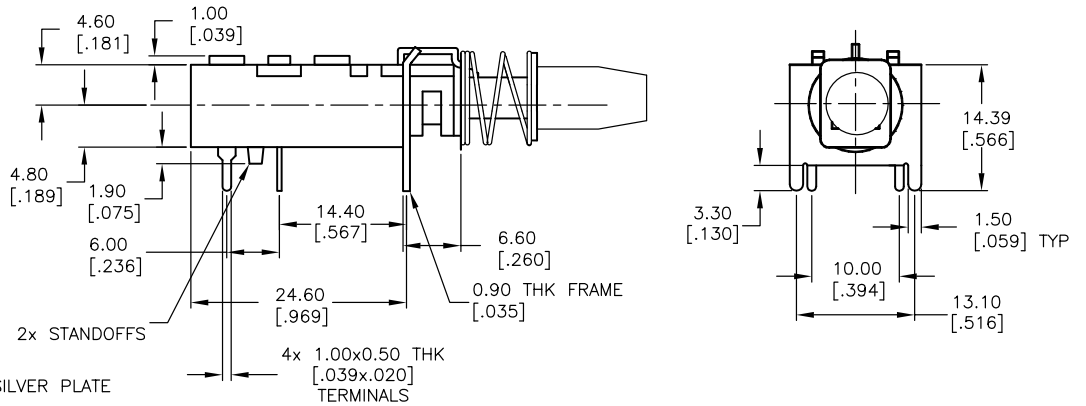

NOTES:

1. ALL DIMENSIONS IN MM [INCH]
2. GENERAL TOLERANCE: X.X=±0.4
X.XX=±0.25
3. TERM. NOS. FOR REFERENCE ONLY.
4. CONTACT MATERIAL: COPPER ALLOY W/ SILVER PLATE
- ▲ 5. RATING: 7A@125V , 4A@250
6. CONTACT RESISTANCE: 20MΩ MAX @ 5V DC 1A
7. DIELECTRIC STRENGTH: AC 1500V RMS
8. OPERATING FORCE: 550±150gf TYP.
9. TRAVEL: FULL:5.5, LOCK:4.0
10. ▲ DENOTES CRITICAL PARAMETER.

E-SWITCH®

TITLE					P227EE1CXCTAMGRY				
SCALE	DATE	DR	DWG	REV					
1.5:1	9/3/03	AR	XP0261A	A					

THE INFORMATION CONTAINED IN THIS DOCUMENT IS PROPRIETARY TO E-SWITCH AND IS NOT TO BE COPIED OR TRANSFERRED