

Dual IGBTMOD™ NFH-Series Module 200 Amperes/1200 Volts

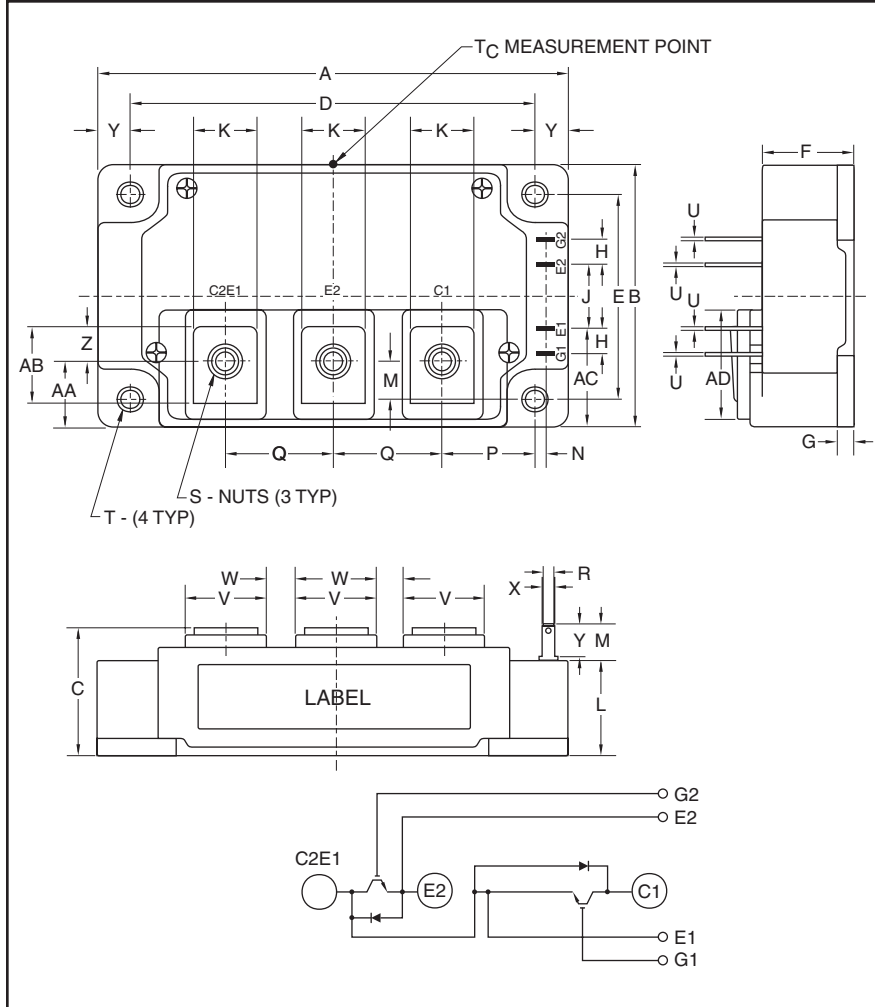

Outline Drawing and Circuit Diagram

Dimensions	Inches	Millimeters
A	4.25	108.0
B	2.44	62.0
C	1.14+0.04/-0.01	29.0+1.0/-0.5
D	3.66±0.01	93.0±0.25
E	1.88±0.01	48.0±0.25
F	0.67	17.0
G	0.16	4.0
H	0.24	6.0
J	0.59	15.0
K	0.55	14.0
L	0.87	22.0
M	0.33	8.5
N	0.10	2.5
P	0.85	21.5

Dimensions	Inches	Millimeters
Q	0.98	25.0
R	0.11	2.8
S	M6 Metric	M6
T	0.26 Dia.	Dia. 6.5
U	0.002	0.5
V	0.71	18.0
W	0.28	7.0
X	0.16	4.0
Y	0.3	7.5
Z	0.325	8.25
AA	0.624	15.85
AB	0.709	18.0
AC	0.69	17.5
AD	1.012	25.7



Description:

Powerex IGBTMOD™ Modules are designed for use in high frequency applications; 30 kHz for hard switching applications and 60 to 70 kHz for soft switching applications. Each module consists of two IGBT Transistors in a half-bridge configuration with each transistor having a reverse-connected super-fast recovery free-wheel diode. All components and interconnects are isolated from the heat sinking baseplate, offering simplified system assembly and thermal management.

Features:

- Low ESW(off)
- Discrete Super-Fast Recovery Free-Wheel Diode
- Isolated Baseplate for Easy Heat Sinking

Applications:

- Power Supplies
- Induction Heating
- Welders

Ordering Information:

Example: Select the complete part module number you desire from the table below -i.e. CM200DU-24NFH is a 1200V (V_{CEs}), 200 Ampere Dual IGBTMOD™ Power Module.

Type	Current Rating Amperes	V _{CEs} Volts (x 50)
CM	200	24

CM200DU-24NFH
Dual IGBTMOD™ NFH-Series Module
 200 Amperes/1200 Volts

Absolute Maximum Ratings, $T_j = 25\text{ °C}$ unless otherwise specified

Ratings	Symbol	CM200DU-24NFH	Units
Junction Temperature	T_j	-40 to 150	°C
Storage Temperature	T_{stg}	-40 to 125	°C
Collector-Emitter Voltage (G-E Short)	V_{CES}	1200	Volts
Gate-Emitter Voltage (C-E Short)	V_{GES}	±20	Volts
Collector Current ($T_C = 25\text{ °C}$)	I_C	200*	Amperes
Peak Collector Current	I_{CM}	400*	Amperes
Emitter Current** ($T_C = 25\text{ °C}$)	I_E	200*	Amperes
Peak Emitter Current**	I_{EM}	400*	Amperes
Maximum Collector Dissipation ($T_C = 25\text{ °C}$, $T_j \leq 150\text{ °C}$)	P_C	830	Watts
Maximum Collector Dissipation ($T_C = 25\text{ °C}$, $T_j \leq 150\text{ °C}$)	P_C	1300	Watts
Mounting Torque, M6 Main Terminal	—	40	in-lb
Mounting Torque, M6 Mounting	—	40	in-lb
Weight	—	400	Grams
Isolation Voltage (Main Terminal to Baseplate, AC 1 min.)	V_{ISO}	2500	Volts

Static Electrical Characteristics, $T_j = 25\text{ °C}$ unless otherwise specified

Characteristics	Symbol	Test Conditions	Min.	Typ.	Max.	Units
Collector-Cutoff Current	I_{CES}	$V_{CE} = V_{CES}$, $V_{GE} = 0V$	—	—	1.0	mA
Gate Leakage Current I_{GES}	$V_{GE} = V_{GES}$, $V_{CE} = 0V$	—	—	0.7	—	μA
Gate-Emitter Threshold Voltage	$V_{GE(th)}$	$I_C = 20mA$, $V_{CE} = 10V$	4.5	6.0	7.5	Volts
Collector-Emitter Saturation Voltage	$V_{CE(sat)}$	$I_C = 200A$, $V_{GE} = 15V$, $T_j = 25\text{ °C}$	—	5.0	6.5	Volts
		$I_C = 200A$, $V_{GE} = 15V$, $T_j = 125\text{ °C}$	—	5.0	—	Volts
Total Gate Charge	Q_G	$V_{CC} = 600V$, $I_C = 200A$, $V_{GE} = 15V$	—	900	—	nC
Emitter-Collector Voltage**	V_{EC}	$I_E = 200A$, $V_{GE} = 0V$	—	—	3.5	Volts

Dynamic Electrical Characteristics, $T_j = 25\text{ °C}$ unless otherwise specified

Characteristics	Symbol	Test Conditions	Min.	Typ.	Max.	Units
Input Capacitance	C_{ies}		—	—	32	nf
Output Capacitance	C_{oes}	$V_{CE} = 10V$, $V_{GE} = 0V$	—	—	2.7	nf
Reverse Transfer Capacitance	C_{res}		—	—	0.6	nf
Inductive Load	Turn-on Delay Time	$V_{CC} = 600V$, $I_C = 200A$,	—	—	300	ns
	Rise Time					
Switch Time	Turn-off Delay Time	$V_{GE1} = V_{GE2} = 15V$, $R_G = 1.6\Omega$, Inductive Load Switching Operation,	—	—	500	ns
	Fall Time					
Diode Reverse Recovery Time**	t_{rr}	$I_E = 200A$	—	—	250	ns
Diode Reverse Recovery Charge**	Q_{rr}		—	7.5	—	μC

* Pulse width and repetition rate should be such that device junction temperature (T_j) does not exceed $T_{j(max)}$ rating.

**Represents characteristics of the anti-parallel, emitter-to-collector free-wheel diode (FWDi).

CM200DU-24NFH
Dual IGBTMOD™ NFH-Series Module
 200 Amperes/1200 Volts

Thermal and Mechanical Characteristics, $T_j = 25\text{ }^\circ\text{C}$ unless otherwise specified

Characteristics	Symbol	Test Conditions	Min.	Typ.	Max.	Units
Thermal Resistance, Junction to Case	$R_{th(j-c)Q}$	Per IGBT 1/2 Module, T_C Reference Point per Outline Drawing	—	—	0.15	$^\circ\text{C/W}$
Thermal Resistance, Junction to Case	$R_{th(j-c)D}$	Per FWDi 1/2 Module, T_C Reference Point per Outline Drawing	—	—	0.24	$^\circ\text{C/W}$
Thermal Resistance, Junction to Case	$R_{th(j-c)'Q}$	Per IGBT 1/2 Module, T_C Reference Point Under Chips	—	—	0.095	$^\circ\text{C/W}$
Thermal Resistance, Junction to Case	$R_{th(j-c)'D}$	Per FWDi 1/2 Module, T_C Reference Point Under Chips	—	—	0.14	$^\circ\text{C/W}$
Contact Thermal Resistance	$R_{th(c-f)}$	Per 1/2 Module, Thermal Grease Applied	—	0.04	—	$^\circ\text{C/W}$
External Gate Resistance	R_G		1.6	—	16	Ω

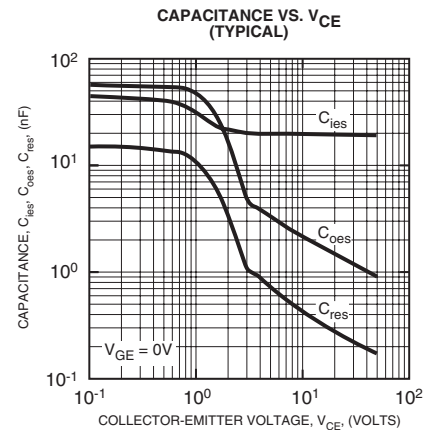
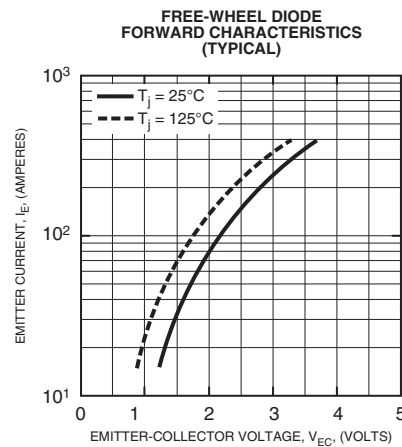
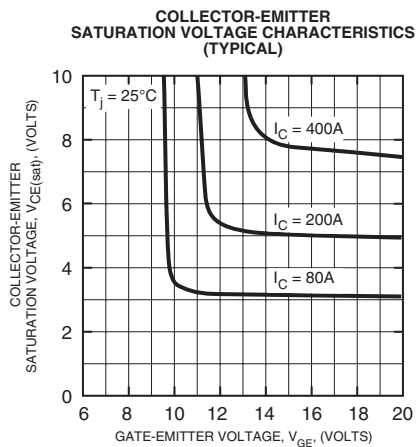
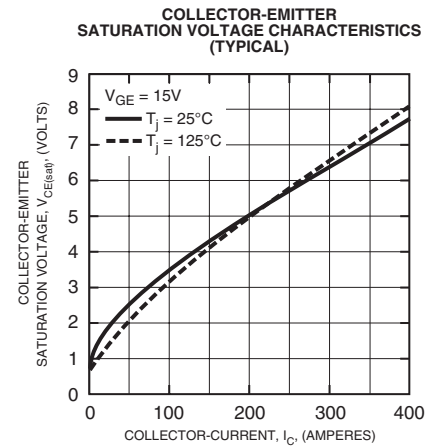
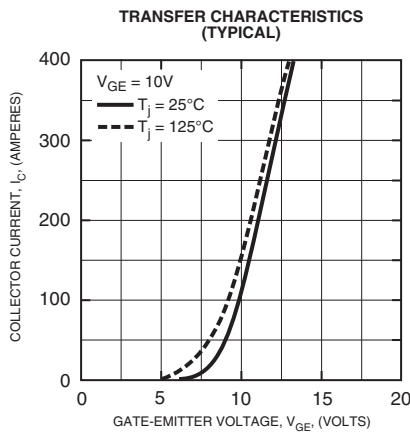
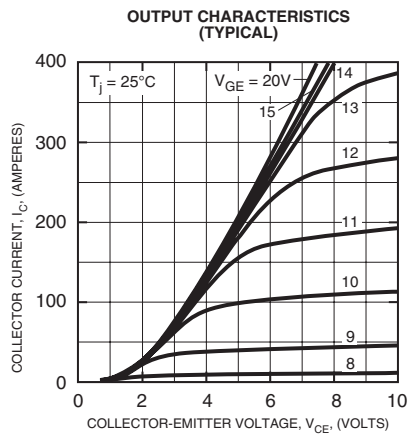

CM200DU-24NFH
Dual IGBTMOD™ NFH-Series Module
 200 Amperes/1200 Volts

