

Converter - Brake - Inverter Module (CB13) with Trench IGBT technology

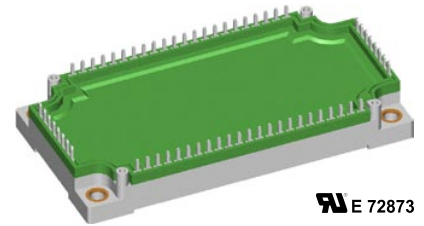
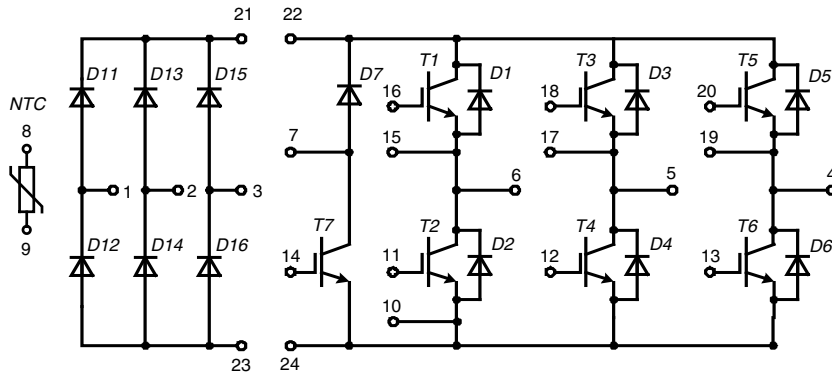

Three Phase Rectifier	Brake Chopper	Three Phase Inverter
$V_{RRM} = 1600 \text{ V}$	$V_{CES} = 1200 \text{ V}$	$V_{CES} = 1200 \text{ V}$
$I_{FAVM} = 50 \text{ A}$	$I_{C25} = 55 \text{ A}$	$I_{C25} = 80 \text{ A}$
$I_{FSM} = 850 \text{ A}$	$V_{CE(sat)} = 1.7 \text{ V}$	$V_{CE(sat)} = 1.7 \text{ V}$

Input Rectifier Bridge D11 - D16		
Symbol	Conditions	Maximum Ratings
V_{RRM}		1600 V
I_{FAV}	$T_C = 80^\circ\text{C}$; sine 180°	50 A
I_{DAVM}	$T_C = 80^\circ\text{C}$; rectangular; $d = 1/3$; bridge	140 A
I_{FSM}	$T_C = 25^\circ\text{C}$; $t = 10 \text{ ms}$; sine 50 Hz	850 A
P_{tot}	$T_C = 25^\circ\text{C}$	125 W

Symbol	Conditions	Characteristic Values			
		min.	typ.	max.	
V_F	$I_F = 50 \text{ A}$; $T_{VJ} = 25^\circ\text{C}$ $T_{VJ} = 125^\circ\text{C}$		1.15 1.05	1.3	V V
I_R	$V_R = V_{RRM}$; $T_{VJ} = 25^\circ\text{C}$ $T_{VJ} = 125^\circ\text{C}$		0.8	0.05	mA mA
R_{thJC}	(per diode)			1.0	K/W

($T_{VJ} = 25^\circ\text{C}$, unless otherwise specified)

Application: AC motor drives with

- Input from single or three phase grid
- Three phase synchronous or asynchronous motor
- electric braking operation

Features

- High level of integration - only one power semiconductor module required for the whole drive
- IGBT technology with low saturation voltage, low switching losses and tail current, high RBSOA and short circuit ruggedness
- Epitaxial free wheeling diodes with Hiperfast and soft reverse recovery
- Industry standard package with insulated copper base plate and soldering pins for PCB mounting
- Temperature sense included

Output Inverter T1 - T6			
Symbol	Conditions	Maximum Ratings	
V_{CES}	$T_{VJ} = 25^{\circ}\text{C}$ to 150°C	1200	V
V_{GES}	Continuous	± 20	V
I_{C25}	$T_C = 25^{\circ}\text{C}$	80	A
I_{C80}	$T_C = 80^{\circ}\text{C}$	50	A
I_{CM}	$T_C = 80^{\circ}\text{C}$; $t_p = 1$ ms	100	A
P_{tot}	$T_C = 25^{\circ}\text{C}$	270	W

Symbol	Conditions	Characteristic Values					
		(T _{VJ} = 25°C, unless otherwise specified)					
		min.	typ.	max.			
$V_{CE(sat)}$	$I_C = 50$ A; $V_{GE} = 15$ V			$T_{VJ} = 25^{\circ}\text{C}$	1.7	2.15	V
				$T_{VJ} = 125^{\circ}\text{C}$	2.0		V
$V_{GE(th)}$	$I_C = 2$ mA; $V_{GE} = V_{CE}$	5	5.8	6.5	V		
I_{CES}	$V_{CE} = V_{CES}$; $V_{GE} = 0$ V			$T_{VJ} = 25^{\circ}\text{C}$		2.7	mA
				$T_{VJ} = 125^{\circ}\text{C}$	0.7		mA
I_{GES}	$V_{CE} = 0$ V; $V_{GE} = \pm 20$ V			400	nA		
C_{ies}	$V_{CE} = 25$ V; $V_{GE} = 0$ V; $f = 1$ MHz		3.5		nF		
Q_{Gon}	$V_{CE} = 600$ V; $V_{GE} = 15$ V; $I_C = 50$ A		470		nC		
$t_{d(on)}$ t_r $t_{d(off)}$ t_f E_{on} E_{off}	Inductive load, $T_{VJ} = 125^{\circ}\text{C}$ $V_{CE} = 600$ V; $I_C = 50$ A $V_{GE} = \pm 15$ V; $R_G = 18$ Ω			90		ns	
				50		ns	
				520		ns	
				90		ns	
				5		mJ	
				6.5		mJ	
RBSOA	$I_C = I_{CM}$; $V_{GE} = 15$ V $R_G = 18$ Ω ; $T_{VJ} = 125^{\circ}\text{C}$	$V_{CEK} \leq V_{CES} - L_S di/dt$			V		
t_{SC} (SCSOA)	$V_{CE} = 720$ V; $V_{GE} = \pm 15$ V; $R_G = 18$ Ω $t_p \leq 10$ μs ; non-repetitive; $T_{VJ} = 125^{\circ}\text{C}$		200		A		
R_{thJC}				0.46	K/W		

Output Inverter D1 - D6							
Symbol	Conditions	Maximum Ratings					
I_{F25}	$T_C = 25^{\circ}\text{C}$	100	A				
I_{F80}	$T_C = 80^{\circ}\text{C}$	50	A				
Symbol	Conditions	Characteristic Values					
		min.	typ.	max.			
V_F	$I_F = 50$ A;			$T_{VJ} = 25^{\circ}\text{C}$	2.1	2.6	V
				$T_{VJ} = 125^{\circ}\text{C}$	1.6		V
I_{RM} Q_{rr} t_{rr} E_{rec}	$I_F = 60$ A; $di_f/dt = -1200$ A/ μs ; $T_{VJ} = 125^{\circ}\text{C}$; $V_R = 600$ V; $V_{GE} = 0$ V			90		A	
				10		μC	
				160		ns	
				4		mJ	
R_{thJC}	(per diode)			0.65	K/W		

Brake Chopper T7

Symbol	Conditions	Maximum Ratings	
V_{CES}	$T_{VJ} = 25^{\circ}\text{C}$ to 150°C	1200	V
V_{GES}	Continuous	± 20	V
I_{C25}	$T_C = 25^{\circ}\text{C}$	55	A
I_{C80}	$T_C = 80^{\circ}\text{C}$	35	A
I_{CM}	$T_C = 80^{\circ}\text{C}$; $t_p = 1$ ms	70	A
P_{tot}	$T_C = 25^{\circ}\text{C}$	200	W

Symbol	Conditions	Characteristic Values			
($T_{VJ} = 25^{\circ}\text{C}$, unless otherwise specified)					
		min.	typ.	max.	

$V_{CE(sat)}$	$I_C = 35$ A; $V_{GE} = 15$ V	$T_{VJ} = 25^{\circ}\text{C}$		1.7	2.15	V
		$T_{VJ} = 125^{\circ}\text{C}$		2.0		V
$V_{GE(th)}$	$I_C = 1.5$ mA; $V_{GE} = V_{CE}$		5	5.8	6.5	V
I_{CES}	$V_{CE} = V_{CES}$; $V_{GE} = 0$ V	$T_{VJ} = 25^{\circ}\text{C}$			0.25	mA
		$T_{VJ} = 125^{\circ}\text{C}$		0.3		mA
I_{GES}	$V_{CE} = 0$ V; $V_{GE} = \pm 20$ V				400	nA
C_{ies}	$V_{CE} = 25$ V; $V_{GE} = 0$ V; $f = 1$ MHz			2.5		nF
Q_{Gon}	$V_{CE} = 600$ V; $V_{GE} = 15$ V; $I_C = 35$ A			330		nC
$t_{d(on)}$	Inductive load, $T_{VJ} = 125^{\circ}\text{C}$ $V_{CE} = 600$ V; $I_C = 35$ A $V_{GE} = \pm 15$ V; $R_G = 27$ Ω			90		ns
t_r				50		ns
$t_{d(off)}$				520		ns
t_f				90		ns
E_{off}				4.8		mJ
RBSOA	$I_C = I_{CM}$; $V_{GE} = 15$ V $R_G = 27$ Ω ; $T_{VJ} = 125^{\circ}\text{C}$			$V_{CEK} \leq V_{CES} - L_S di/dt$		V
t_{SC} (SCSOA)	$V_{CE} = 720$ V; $V_{GE} = \pm 15$ V; $R_G = 27$ Ω $t_p \leq 10$ μs ; non-repetitive; $T_{VJ} = 125^{\circ}\text{C}$			140		A
R_{thJC}				0.62		K/W

Brake Chopper D7

Symbol	Conditions	Maximum Ratings	
V_{RRM}	$T_{VJ} = 25^{\circ}\text{C}$ to 150°C	1200	V
I_{F25}	$T_C = 25^{\circ}\text{C}$	48	A
I_{F80}	$T_C = 80^{\circ}\text{C}$	30	A

Symbol	Conditions	Characteristic Values			
		min.	typ.	max.	

V_F	$I_F = 35$ A;	$T_{VJ} = 25^{\circ}\text{C}$		2.5	3.3	V
		$T_{VJ} = 125^{\circ}\text{C}$		2.0		V
I_R	$V_R = V_{RRM}$;	$T_{VJ} = 25^{\circ}\text{C}$			0.25	mA
		$T_{VJ} = 125^{\circ}\text{C}$		0.5		mA
R_{thJC}	(per diode)				1.2	K/W

Temperature Sensor NTC

Symbol	Conditions	Characteristic Values			
		min.	typ.	max.	
R_{25}	$T = 25^{\circ}\text{C}$	4.75	5.0	5.25	$\text{k}\Omega$
$B_{25/50}$			3375		K

Module

Symbol	Conditions	Maximum Ratings	
T_{VJ}	operating	-40...+125	$^{\circ}\text{C}$
T_{JM}		+150	$^{\circ}\text{C}$
T_{stg}		-40...+125	$^{\circ}\text{C}$
V_{ISO}	$I_{ISO} \leq 1 \text{ mA}; 50/60 \text{ Hz}$	2500	V~
M_d	Mounting torque (M5)	3 - 6	Nm

Symbol	Conditions	Characteristic Values		
		min.	typ.	max.
$R_{therm-chip}$	Resistance terminal to chip		5	$\text{m}\Omega$
d_S	Creepage distance on surface	6		mm
d_A	Strike distance in air	6		mm
R_{thCH}	with heatsink compound		0.01	K/W
Weight			300	g

Dimensions in mm (1 mm = 0.0394")

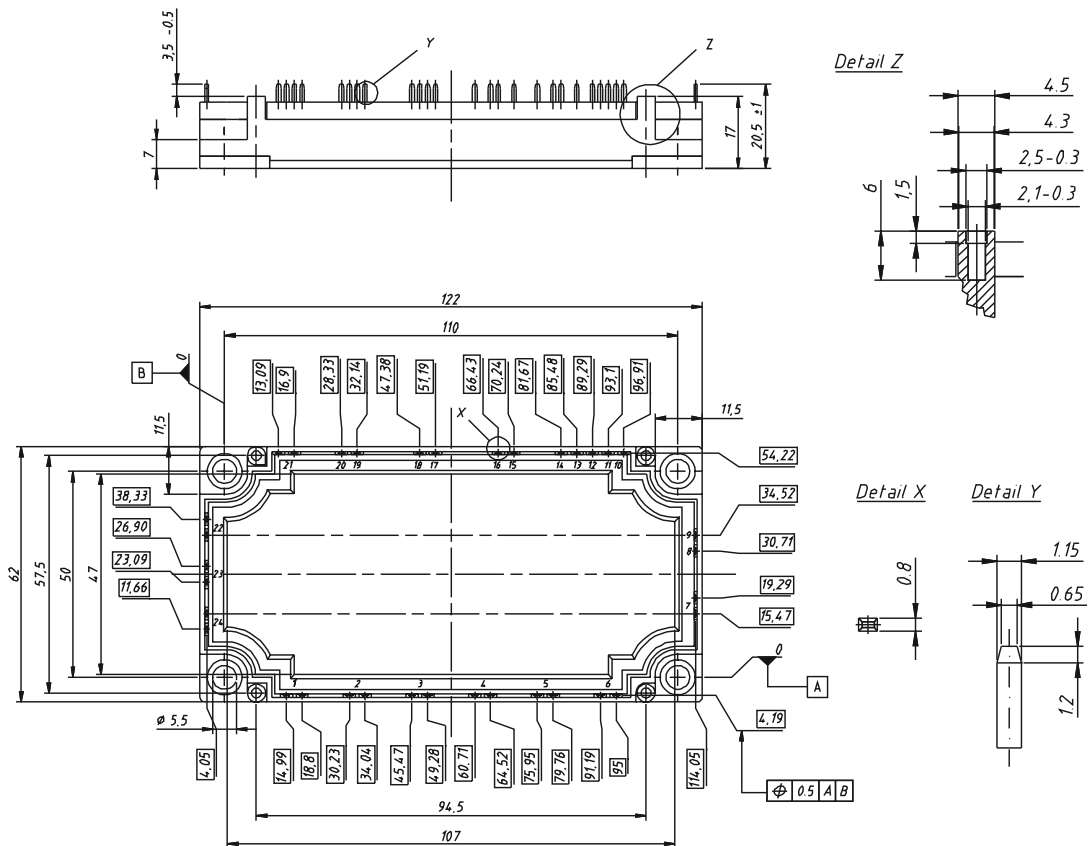

IXYS reserves the right to change limits, test conditions and dimensions.

© 2006 IXYS All rights reserved

Input Rectifier Bridge D11 - D16

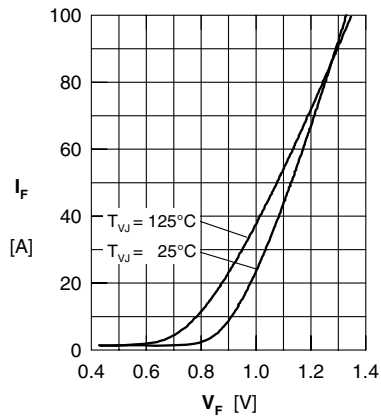

Fig. 1 Typ. forward current vs. voltage drop per diode

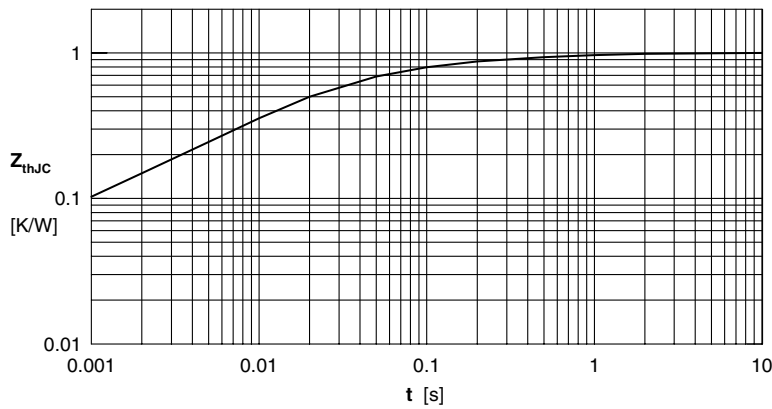

Fig. 2 Transient thermal impedance junction to case

Output Inverter T1 - T6 / D1 - D6

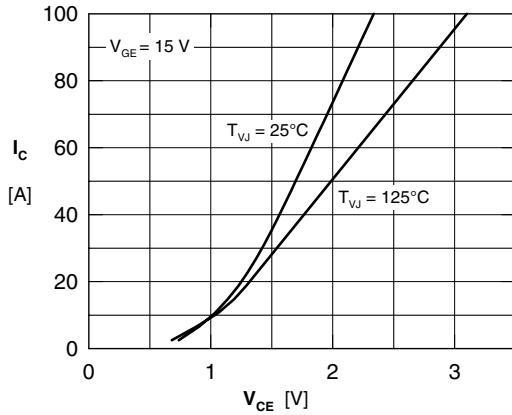

Fig. 3 Typical output characteristic

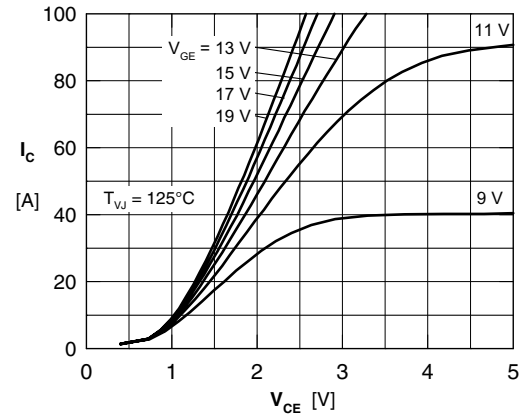

Fig. 4 Typical output characteristic

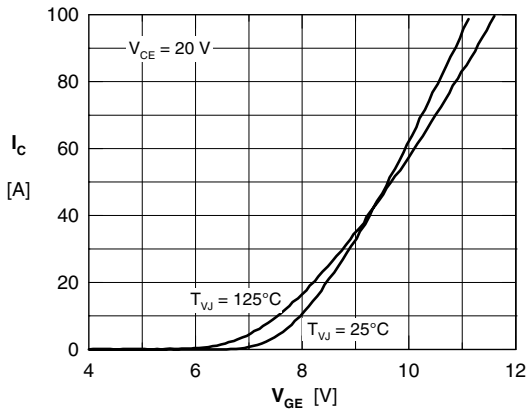

Fig. 5 Typical transfer characteristic

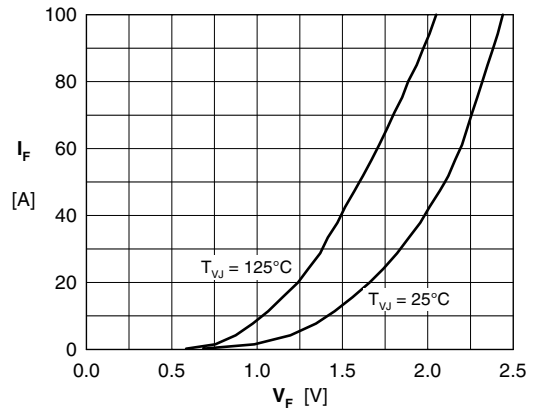

Fig. 6 Typical forward characteristic of free wheeling diode

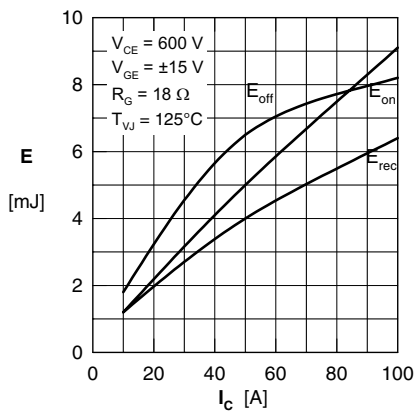

Fig. 7 Typ. switching losses vs. collector current

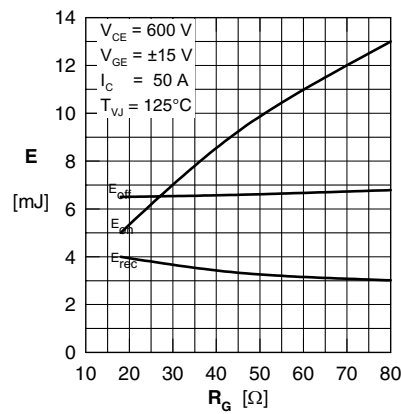

Fig. 8 Typ. switching losses vs. gate resistance

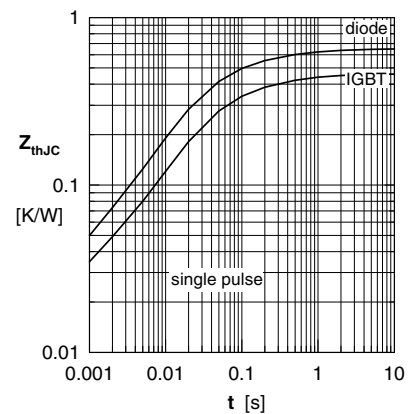

Fig. 9 Transient thermal impedance

IXYS reserves the right to change limits, test conditions and dimensions.

© 2006 IXYS All rights reserved

0646

Brake Chopper T7 / D7

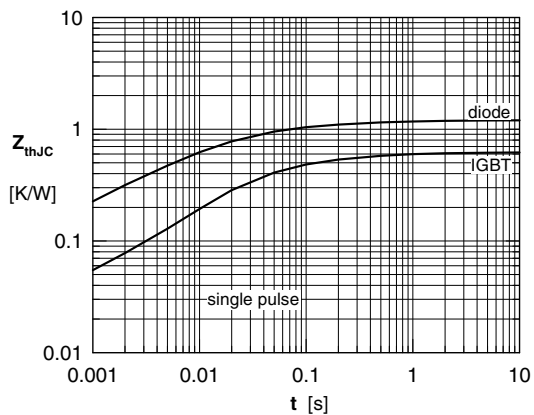
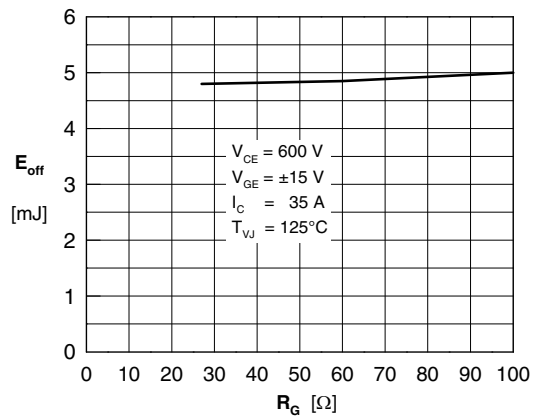
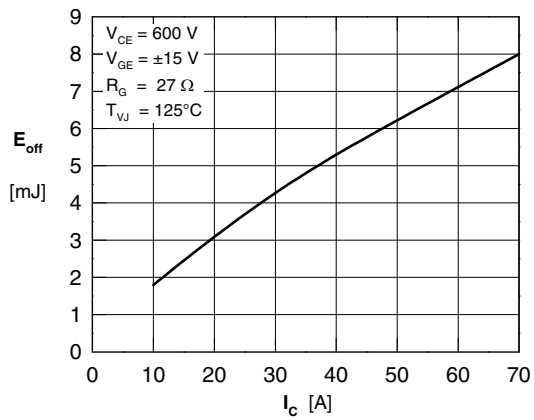
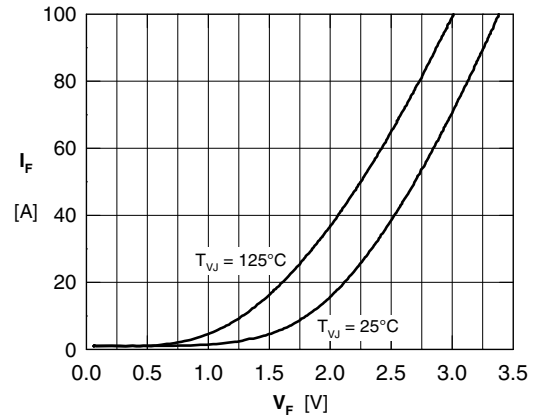
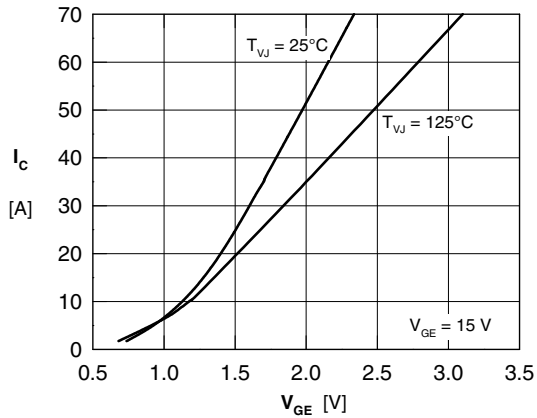

Temperature Sensor NTC

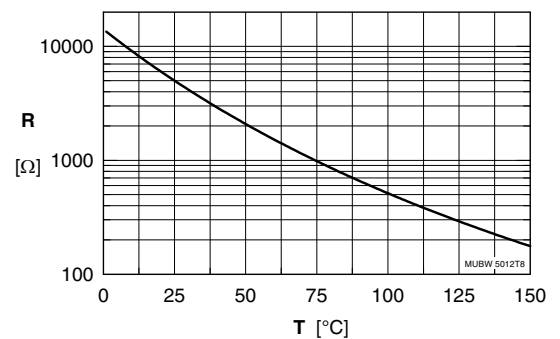

IXYS reserves the right to change limits, test conditions and dimensions.

© 2006 IXYS All rights reserved

0646