

P.C. MOUNTING

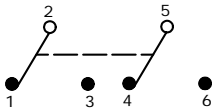

CIRCUIT: 2PDT

NOTES:

1. ALL DIMENSIONS IN MM [INCH]
2. GENERAL TOLERANCE: X.X=±0.4  
X.XX=±0.25
3. TERM. NOS. FOR REFERENCE ONLY.
4. RATING 0.1A @30V DC
- ▲5. MATERIALS:  
CONTACT/TERMINALS: SILVER PLATE  
HOUSING: PBT UL94HB  
BASE: PA66 UL94HB  
ACTUATOR: POM
6. CONTACT RESISTANCE: 100 MILLI-OHM (INITIAL)
- ▲7. TIMING: NON-SHORTING
8. OPERATING FORCE: 230±50GF
9. TRAVEL: LATCHING  
2MM TO LOCK  
3MM OVERALL
10. ELECTRICAL LIFE: 10000 CYCLES
11. OPERATING TEMP: -20°C TO +70°C
12. ▲DENOTES CRITICAL PARAMETER.
- 13 2002/95/EC (ROHS) COMPLIANT

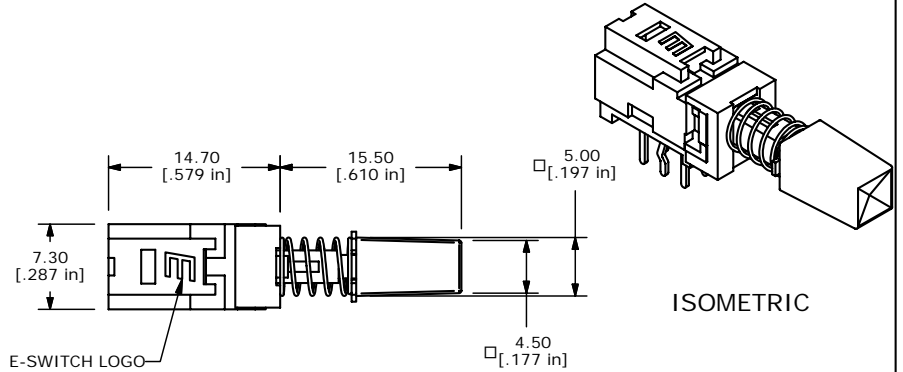

ISOMETRIC

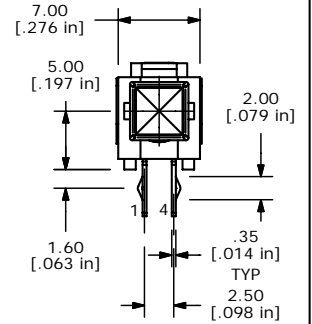
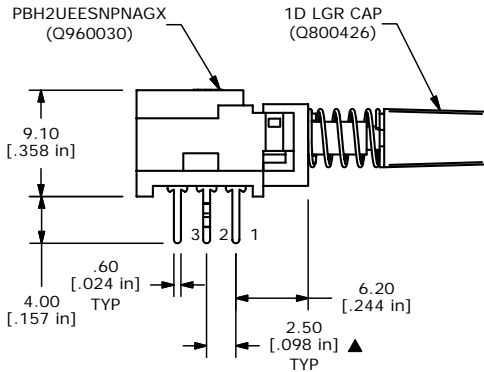

**E-SWITCH®**

TITLE PBH2UEESNPAG1DLGR

A	16119	RELEASED FOR PRODUCTION	6/9/06	CT
REV	PCR NO	DESCRIPTION	DATE	BY

THE INFORMATION CONTAINED IN THIS DOCUMENT IS PROPRIETARY TO E-SWITCH AND IS NOT TO BE COPIED OR TRANSFERRED

SCALE	DATE	DR	DWG	REV
2:1	6/9/2006	CT	XQ0020P	A