

ISOMETRIC

- NOTES:
1. ALL DIMENSIONS IN MM [INCH]
 2. GENERAL TOLERANCE: X.X=±0.4
X.XX=±0.25
 3. TERM. NOS. FOR REFERENCE ONLY.
 4. RATING 0.1A @30V DC
 - ▲5. MATERIALS:
CONTACT/TERMINALS: SILVER PLATE
HOUSING: PBT UL94HB
BASE: PA66 UL94HB
ACTUATOR: POM
CAP: ABS UL94VO
 6. CONTACT RESISTANCE: 100 MILLI-OHM (INITIAL)
 - ▲7. TIMING: NON-SHORTING
 8. OPERATING FORCE: 230±50GF
 9. TRAVEL: LATCHING
2MM TO LOCK
3MM OVERALL
 10. ELECTRICAL LIFE: 10000 CYCLES
 11. OPERATING TEMP: -20°C TO +70°C
 12. ▲ DENOTES CRITICAL PARAMETER.
 13. 2002/95/EC (ROHS) COMPLIANT
 14. PACKAGE: TRAYS- 120pcs for one tray.

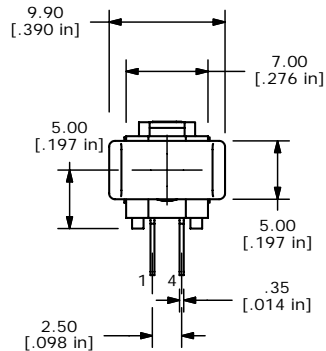
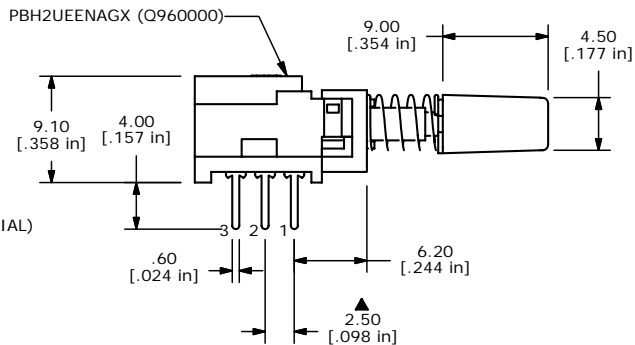

E-SWITCH®

TITLE PBH2UEENAG1CWHT

A	16815	RELEASED FOR PRODUCTION	1/8/07	TN
REV	PCR NO	DESCRIPTION	DATE	BY

THE INFORMATION CONTAINED IN THIS DOCUMENT IS PROPRIETARY TO E-SWITCH AND IS NOT TO BE COPIED OR TRANSFERRED

SCALE	DATE	DR	DWG	REV
2:1	1/8/2007	TN	XQ0028P	A