

RECOMMENDED PANEL
 MOUNTING

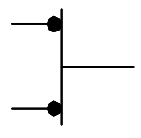

CIRCUIT: 2P, SPST
 CONTACT CONFIGURATION
 ON (OFF)

NOTES:

1. ALL DIMENSIONS IN MM [INCH]
2. GENERAL TOLERANCE: X.X=±0.4
 X.XX=±0.25
3. TERM. NOS. FOR REF. ONLY
4. RATING: 3A 125V, 1.5A 250V AC
5. CONTACT RESISTANCE: 50m ohm max.
6. INSULATION RESISTANCE: DC 500V 100M ohm min.
7. DIELECTRIC STRENGTHS: AC 1000V 1 minute
8. ACTUATOR COLOR: YELLOW

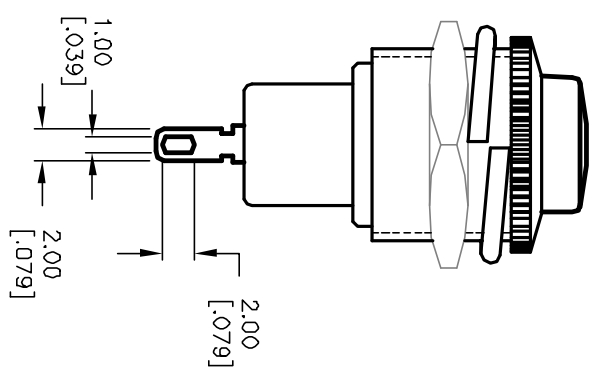
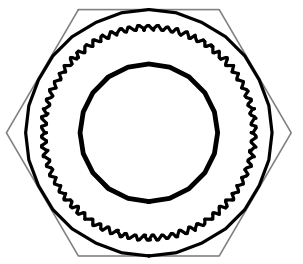
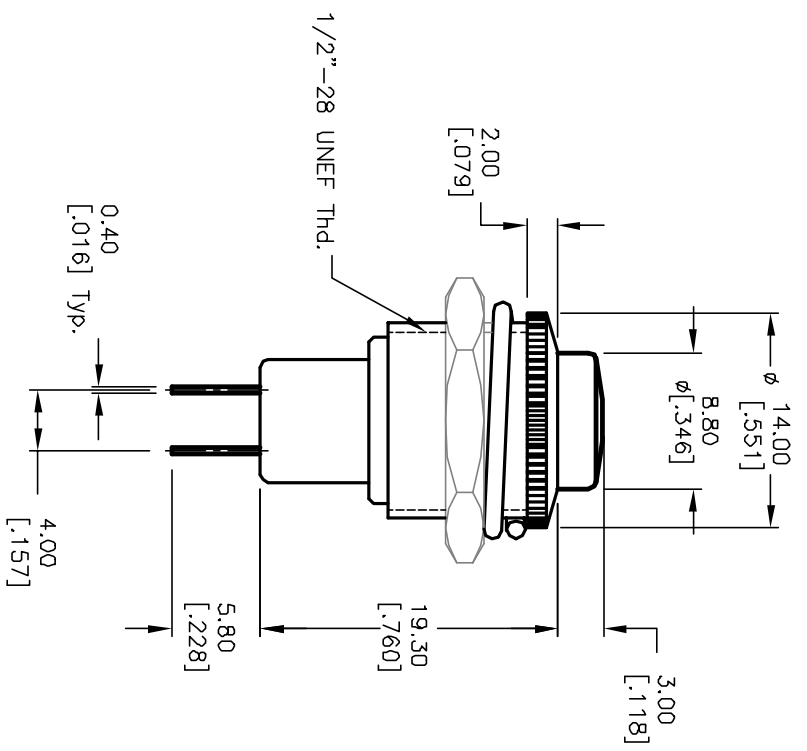

REV.	ECN No.	DESCRIPTION	DATE	CHKD
A	12156	REFER TO OLD TAB#F030019_A	5/21/02	CB
THE INFORMATION CONTAINED IN THIS DOCUMENT IS PROPRIETARY TO E-SWITCH AND IS NOT TO BE COPIED OR TRANSFERRED				

TITLE	SCALE	DATE	DR	DWG	REV
RP3502MB-YEL	2:1	2/15/00	MM	F030021	A

