

SUGGESTED PANEL CUTOUT

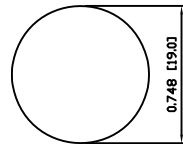

MAXIMUM PANEL THICKNESS: 0.472 [12.0mm]

SCHEMATIC

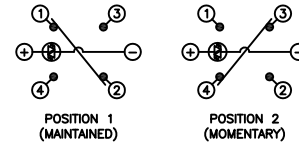

SPECIFICATIONS

- FUNCTION:  
1PNO OFF-(ON) + 1PNC ON-(OFF)
- RATING:  
2A 48VDC
- ILLUMINATION VOLTAGE:  
2.8V 20mA
- CONTACT RESISTANCE:  
Initial: 50mΩ Max. at 1A 12VDC
- INSULATION RESISTANCE:  
1,000MΩ Min. at 500VDC
- DIELECTRIC STRENGTH:  
2,000VAC Min. for 1 Minute
- ELECTRICAL LIFE:  
50,000 Cycles
- MECHANICAL LIFE:  
1,000,000 Cycles
- TEMPERATURE:  
Operating: -20°C to 70°C
- INGRESS PROTECTION:  
IP65
- APPROVALS:  
**RoHS**  
COMPLIANT

MATERIALS

- BUSHING:  
Stainless Steel (304)
- BASE:  
Polycarbonate (PC), UL94 V-2
- ACTUATOR:  
Stainless Steel (304)  
Polycarbonate (PC), UL94 V-2
- HARDWARE:  
Nickel Plated Brass (H59)
- SEALING:  
Silicone  
Stainless Steel (304)
- INNER ASSEMBLY:  
Polycarbonate (PC), UL94 V-2  
Brass (H59)
- SPRING:  
Steel (Cr18Ni9)
- CONTACTS:  
Silver Plated Copper
- TERMINALS:  
Brass (H59)
- O-RING:  
Nitrile Butadiene Rubber (NBR)

COLORS AND FINISH

- BEZEL:  
Stainless Steel  
Machine Finish
- ACTUATOR:  
Stainless Steel  
Machine Finish
- ILLUMINATION:  
Blue (Forward)  
Blue (Reverse)
- MARKING:  
None

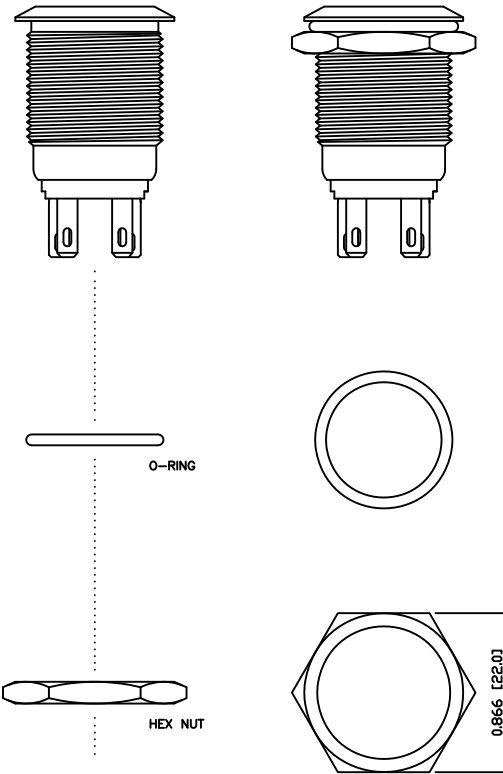

EXPLODED VIEW

ASSEMBLED VIEW

BODY	A	09/07/24	CAB
COLORS	A	09/07/24	CAB
MATERIALS	B	09/10/16	CAB
SPECIFICATIONS	A	09/07/27	CAB
REFERENCE	REV.	DATE	BY

THE INFORMATION CONTAINED IN THIS DOCUMENT IS PROPRIETARY TO E-SWITCH AND IS NOT TO BE COPIED OR TRANSFERRED

B	CORRECTED TERMINAL MATERIAL	PCRD0167	09/10/16	CAB
A	INITIAL RELEASE	PCRD0051	09/08/05	CAB
REV.	DESCRIPTION	PCR	DATE	DRAWN BY

DIMENSIONS	
INCHES [MILLIMETERS]	
GENERAL TOLERANCES	
±0.008 [±0.2] / ±1'	
SCALE	PROJECTION
DRAWING NOT TO SCALE	1st Angle

## PV4F2Y0SS-341

DRAWING NUMBER 52-PV4F2Y0SS341	DATE OCTOBER 16, 2009	REVISION B
-----------------------------------	--------------------------	---------------