

SCHEMATIC

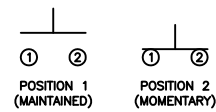

SPECIFICATIONS

FUNCTION:
1P1T OFF-(ON)

RATING:
2A 48VDC

CONTACT RESISTANCE:
Initial: 50mΩ Max. at 1A 12VDC

INSULATION RESISTANCE:
1,000MΩ Min. at 500VDC

DIELECTRIC STRENGTH:
2,000VAC Min. for 1 Minute

ELECTRICAL LIFE:
200,000 Cycles

MECHANICAL LIFE:
1,000,000 Cycles

INGRESS PROTECTION:
IP65

TEMPERATURE:
Operating: -20°C to 70°C

APPROVALS:
RoHS
COMPLIANT

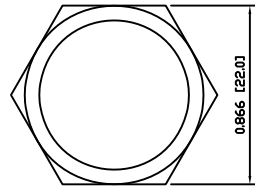
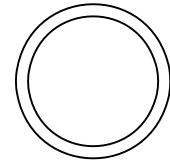
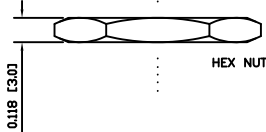
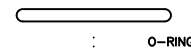
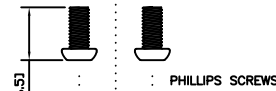
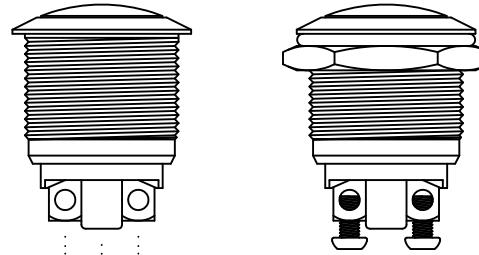
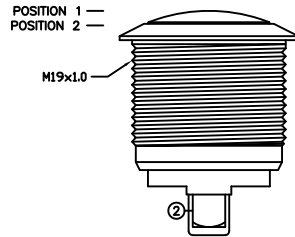
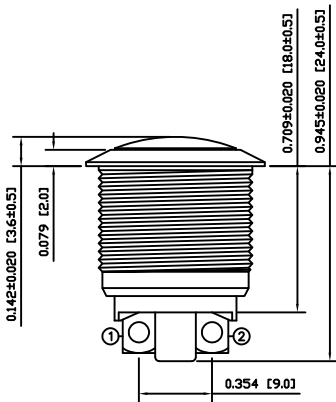
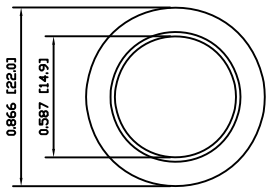

EXPLODED VIEW

ASSEMBLED VIEW

COLORS AND FINISH

BEZEL:
Black
Anodized Finish

ACTUATOR:
Black
Anodized Finish

MATERIALS

BUSHING:
Aluminum

BASE:
Polybutylene Terephthalate (PBT), UL94 V-2

ACTUATOR:
Aluminum

HARDWARE:
Nickel Plated Brass (H59)

SEALING:
Silicone
Stainless Steel (304)

INNER ASSEMBLY:
Polyamide 6/6 (PA66)
Brass (H59)

SPRING:
Steel (Cr18Ni9)

CONTACTS:
Silver Plated Copper

TERMINALS:
Silver Plated Brass (H59)
Steel (A3)

O-RING:
Nitrile Butadiene Rubber (NBR)

SUGGESTED PANEL CUTOUT

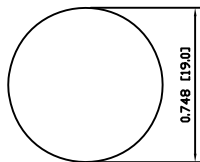

MAXIMUM PANEL THICKNESS: 0.315 [8.0mm]

BODY	A	09/07/06	CAB
MATERIALS	A	09/07/07	CAB
SPECIFICATIONS	A	09/07/07	CAB
REFERENCE	REV.	DATE	BY

THE INFORMATION CONTAINED IN THIS DOCUMENT IS PROPRIETARY TO E-SWITCH AND IS NOT TO BE COPIED OR TRANSFERRED

A	INITIAL RELEASE	PCRD0051	09/08/05	CAB
REV.	DESCRIPTION	PCR	DATE	DRAWN BY

DIMENSIONS	
INCHES [MILLIMETERS]	
GENERAL TOLERANCES	
±0.008 [±0.2] / ±1'	
SCALE	PROJECTION
DRAWING NOT TO SCALE	1st Angle

PV1S64011			
DRAWING NUMBER	DATE	REVISION	
52-PV1S64011	AUGUST 5, 2009	A	