

ISOMETRIC

| ▲ LED SPECIFICATION | | |
|------------------------|----------|----------|
| Column 1 | Column 2 | Column 3 |
| LED PARAMETER | UNITS | RED |
| FORWARD CURRENT | mA | 20 |
| FORWARD VOLTAGE @ 20mA | V | 2.1-2.6 |
| LUMINOUS INTENSITY | mcd | 42-100 |

NOTE:

1. ALL DIMENSIONS IN MM [INCH]
2. GENERAL TOLERANCE: X.X=±0.4
X.XX=±0.25
3. TERMINAL NUMBERS FOR REF ONLY
4. CIRCUIT: SPST OFF-MOMENTARY ON
5. CONTACT MATERIAL: Gold over SILVER
- ▲ 6. RATING: 125mA @ 125 VAC
100mA @ 50 VDC
7. ELECTRIC LIFE: 500,000 CYCLES AT FULL LOAD
8. CONTACT RESISTANCE: 50 milli-OHM max. (INITIAL)
9. INSULATION RESISTANCE: 1,000 MEGA-OHM min. @ 500VDC.
10. DIELECTRIC STRENGTH: 1,000 VAC rms.
11. OPERATING FORCE: 300 gf +/- 100 gf
12. OPERATING TEMPERATURE: -30°C TO +85°C.
13. CONTACT BOUNCE: 10ms MAX.
- ▲ 14. TRAVEL: 1.5mm
15. PANEL THICKNESS RANGE: 1.5 - 4.0 mm.
16. ▲ DENOTES CRITICAL PARAMETER.
17. 2002/95/EC (ROHS) COMPLIANT
18. MAX MOUNTING TORQUE: 1.5 Nm APPLIED TO THE NUT
- ▲ 19. HARDWARE INCLUDED:
 1. T081101 LOCK WASHER (1)
 2. T081102 HEX NUT (1)
 3. T081100 RUBBER WASHER (1)

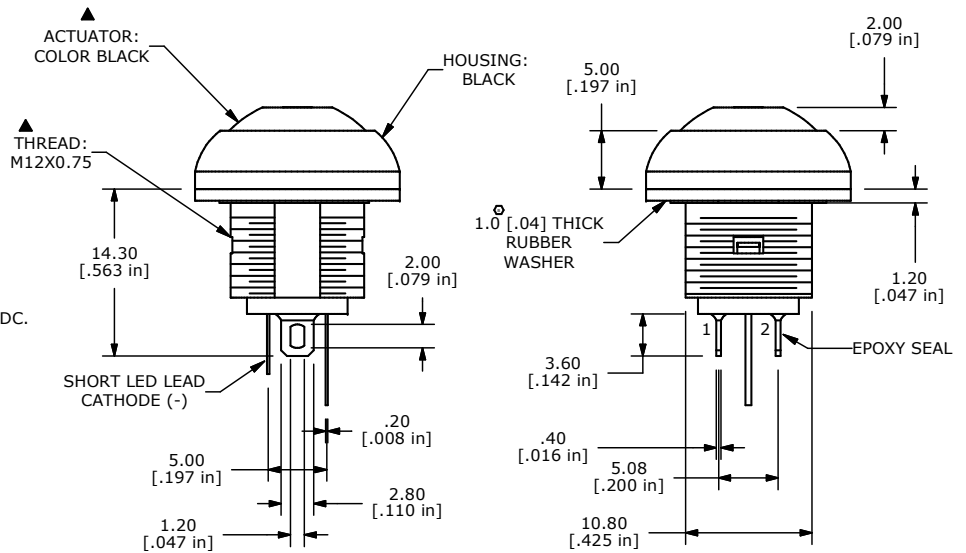

| | | | | |
|-----|--------|--------------------|----------|----|
| B | 17943 | Dim was 1.0[0.025] | 1/24/08 | rc |
| A | 17904 | New-Release | 12/20/07 | rc |
| REV | PCR NO | DESCRIPTION | DATE | BY |

| | | | | |
|-----------------------------|-----------------|-------|--------------|-------|
| TITLE RP8100B2M1CEBLKBLKRED | | | | |
| SCALE 2 : 1 | DATE 12/13/2007 | DR rc | DWG ST081020 | REV B |

THE INFORMATION CONTAINED IN THIS DOCUMENT IS PROPRIETARY TO E-SWITCH AND IS NOT TO BE COPIED OR TRANSFERRED