

SHEET OF

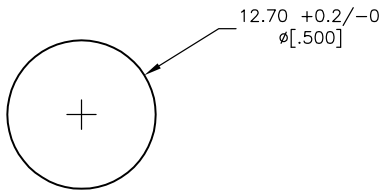

RECOMMEND PANEL MOUNTING

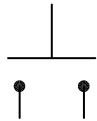

CIRCUIT: 2P; SPST  
CONTACT CONFIGURATION  
OFF (ON)

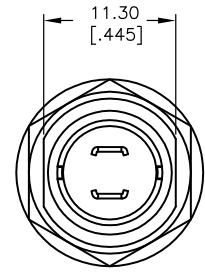
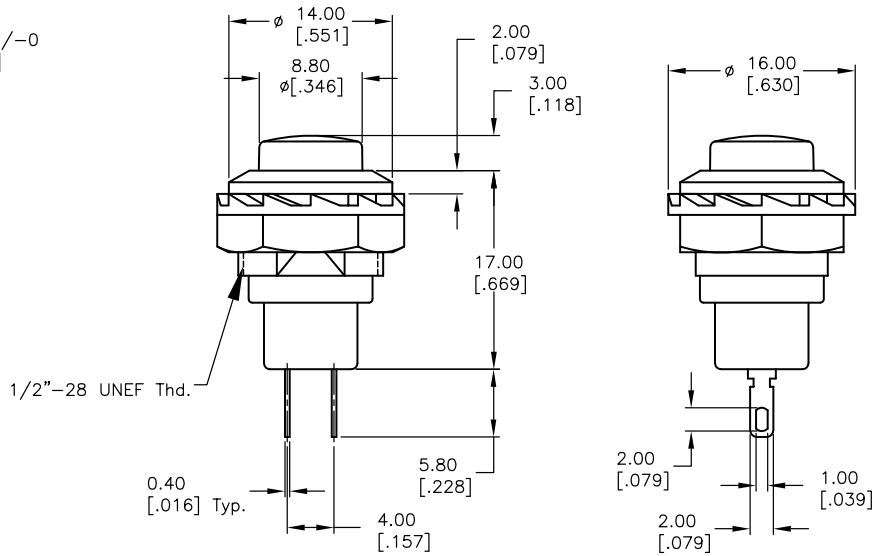

NOTES:

1. ALL DIMENSIONS IN MM [INCH]
2. GENERAL TOLERANCE: 0.0±0.4  
0.00±0.25
3. TERM. NOS. FOR REF. ONLY
4. RATING: 3A 125V, 1.5A 250V AC
5. CONTACT RESISTANCE: 50m ohm max.
6. INSULATION RESISTANCE: DC 500V 100M ohm min.
7. DIELECTRIC STRENGTHS: AC 1000V 1 minute

**E-SWITCH®**

TITLE					RP3502A-RED				
SCALE	DATE	DR	DWG	REV					
2:1	2/8/00	MM	F030012	A					

REV.	ECN No.	DESCRIPTION	DATE	CHKD
A	10522	RELEASED FOR PRODUCTION		

THE INFORMATION CONTAINED IN THIS DOCUMENT IS PROPRIETARY TO E-SWITCH AND IS NOT TO BE COPIED OR TRANSFERRED