

NOTES:

1. ALL DIMENSIONS IN MM[INCH]
2. GENERAL TOLERANCE: X.XX±0.2mm
3. RATING: DC 12V, 50mA
4. CONTACT ARRANGEMENT: SPST, NORMALLY OPEN.
5. OPERATING TEMP: -20C TO +70C
6. STORAGE TEMP: -40C TO +85C
7. PACKAGE: TAPE AND REEL, 2500 PER REEL.
8. CONTACT MATERIAL: SILVER
9. CONTACT RESISTANCE: 100m Ohms MAX(Initial).
10. INSULATION RESISTANCE: 100M Ohms Min.
11. 2002/95/EC (ROHS) COMPLIANT
- ▲12. ACTUATION FORCE: 320+80/-60 GRAMS CENTER, 180+/-60 4 TILT POSITIONS.
- ▲13. TRAVEL: 0.25±0.15mm
14. OPERATING LIFE: 200,000 CYCLES.
- 15.▲DENOTES CRITICAL PARAMETER.

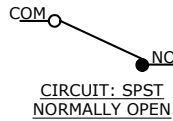
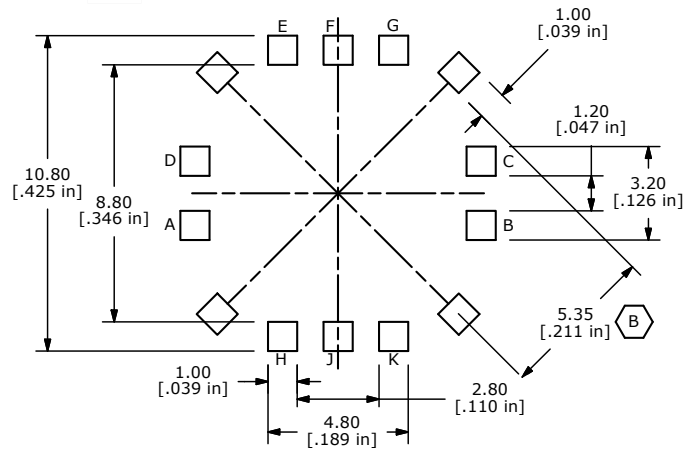

P.C.B. LAYOUT

CIRCUIT TABLE	
ACTUATION POSITION	CIRCUIT
1	D-E
2	C-G
3	F-J
4	A-H
5	B-K

REV	PCR NO	DESCRIPTION	DATE	BY
D	19618	DRAWING CLEAN-UP	01/25/11	BMA
C	18001	Update Notes to New Spec	3/10/08	rc
B	17906	chg location of 5.35 dim	12/20/07	rc
A	16777	RELEASED FOR PRODUCTION	12/20/06	TN

THE INFORMATION CONTAINED IN THIS DOCUMENT IS PROPRIETARY TO E-SWITCH AND IS NOT TO BE COPIED OR TRANSFERRED



TITLE JS1300AQ

SCALE	DATE	DR	DWG	REV
5:1	12/20/2006	TN	N211123	D