

CIRCUIT: SPST
CONTACT CONFIGURATION

SWITCH FUNCTION	
POS 1	POS 2
↶	↷
DNF	DN

LEGEND
 ○ = OFF POSITION
 ■ = INDICATES KEY PULL
 ✕ = INDICATES NO KEY PULL

RECOMMENDED PANEL CUTOUT

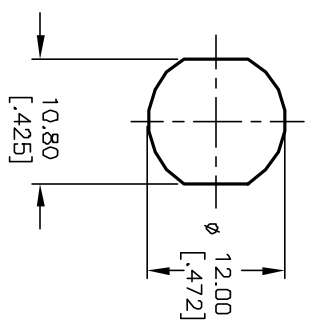

NOTES:

1. ALL DIMENSIONS IN MM [INCH]
2. GENERAL TOLERANCE: X.X=±0.4
X.XX=±0.25
3. TERM. NOS. FOR REFERENCE ONLY.
4. RATING: 1A @125VAC, 0.5A @250VAC
5. CONTACT RESISTANCE: 10mΩ-1-Ω
6. DIELECTRIC STRENGTH: 1000 VAC-1Minute
7. MATERIALS:

HOUSING: ZINC ALLOY DIE CAST
 CYLINDER: ZINC ALLOY W/CHROME PLATING
 TERMINAL AND CONTACTS: SILVER PLATED
 KEYS (2) KEY CODE 1097: ZINC ALLOY, CHROME PLATING

REV.	ECN No.	DESCRIPTION	DATE	CHKD
A	11732	RELEASED FOR PRODUCTION	10/19/01	CJB

TITLE		SCALE	DATE	DR	DWG	REV
K0132A-1097		1.5:1	10/19/01	CJB	K400113	A



THE INFORMATION CONTAINED IN THIS DOCUMENT IS PROPRIETARY TO E-SWITCH AND IS NOT TO BE COPIED OR TRANSFERRED