

# IGBT Modules

Short Circuit SOA Capability

Square RBSOA

$$I_{C25} = 135 \text{ A}$$

$$V_{CES} = 1200 \text{ V}$$

$$V_{CE(sat) \text{ typ.}} = 2.2 \text{ V}$$

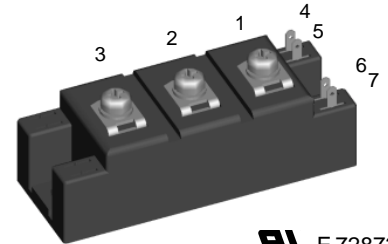
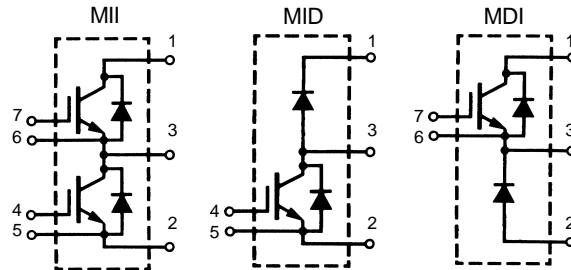

E72873

Symbol	Conditions	Maximum Ratings	
$V_{CES}$	$T_J = 25^\circ\text{C}$ to $150^\circ\text{C}$	1200	V
$V_{CGR}$	$T_J = 25^\circ\text{C}$ to $150^\circ\text{C}$ ; $R_{GE} = 20 \text{ k}\Omega$	1200	V
$V_{GES}$	Continuous	$\pm 20$	V
$V_{GEM}$	Transient	$\pm 30$	V
$I_{C25}$	$T_C = 25^\circ\text{C}$	135	A
$I_{C80}$	$T_C = 80^\circ\text{C}$	90	A
$I_{CM}$	$T_C = 80^\circ\text{C}$ , $t_p = 1 \text{ ms}$	180	A
$t_{SC}$ <b>(SCSOA)</b>	$V_{GE} = \pm 15 \text{ V}$ , $V_{CE} = V_{CES}$ , $T_J = 125^\circ\text{C}$ $R_G = 15 \Omega$ , non repetitive	10	$\mu\text{s}$
<b>RBSOA</b>	$V_{GE} = \pm 15 \text{ V}$ , $T_J = 125^\circ\text{C}$ , $R_G = 15 \Omega$ Clamped inductive load, $L = 100 \mu\text{H}$	$I_{CM} = 150$ $V_{CEK} \leq V_{CES}$	A
$P_{tot}$	$T_C = 25^\circ\text{C}$	560	W
$T_J$		150	$^\circ\text{C}$
$T_{stg}$		-40 ... +150	$^\circ\text{C}$
$V_{ISOL}$	50/60 Hz, RMS $t = 1 \text{ min}$ $I_{ISOL} \leq 1 \text{ mA}$ $t = 1 \text{ s}$ Insulating material: $\text{Al}_2\text{O}_3$	4000 4800	V~ V~
$M_d$	Mounting torque (module)  (terminals)	2.25-2.75 20-25 2.5-3.7 22-33	Nm lb.in. Nm lb.in.
$d_s$	Creepage distance on surface	12.7	mm
$d_A$	Strike distance through air	9.6	mm
$a$	Max. allowable acceleration	50	$\text{m/s}^2$
<b>Weight</b>	Typical	130 4.6	g oz.

Data according to a single IGBT/FRED unless otherwise stated.

## Features

- NPT IGBT technology
- low saturation voltage
- low switching losses
- switching frequency up to 30 kHz
- square RBSOA, no latch up
- high short circuit capability
- positive temperature coefficient for easy paralleling
- MOS input, voltage controlled
- ultra fast free wheeling diodes
- package with DCB ceramic base plate
- isolation voltage 4800 V
- UL registered E72873

## Advantages

- space and weight savings
- reduced protection circuits

## Typical Applications

- AC and DC motor control
- AC servo and robot drives
- power supplies
- welding inverters

Symbol	Conditions	Characteristic Values ( $T_J = 25^\circ\text{C}$ , unless otherwise specified)		
		min.	typ.	max.
$V_{(BR)CES}$	$V_{GE} = 0\text{ V}$	1200		V
$V_{GE(th)}$	$I_C = 3\text{ mA}, V_{CE} = V_{GE}$	4.5		6.5 V
$I_{CES}$	$V_{CE} = V_{CES}$ $T_J = 25^\circ\text{C}$ $T_J = 125^\circ\text{C}$		7.5	5 mA mA
$I_{GES}$	$V_{CE} = 0\text{ V}, V_{GE} = \pm 20\text{ V}$			$\pm 300\text{ nA}$
$V_{CE(sat)}$	$I_C = 75\text{ A}, V_{GE} = 15\text{ V}$		2.2	2.7 V
$C_{ies}$	$V_{CE} = 25\text{ V}, V_{GE} = 0\text{ V}, f = 1\text{ MHz}$		5.5	nF
$C_{oes}$			0.75	nF
$C_{res}$			0.33	nF
$t_{d(on)}$	<b>Inductive load, <math>T_J = 125^\circ\text{C}</math></b> $I_C = 75\text{ A}, V_{GE} = \pm 15\text{ V}$ $V_{CE} = 600\text{ V}, R_G = 15\ \Omega$		100	ns
$t_r$			50	ns
$t_{d(off)}$			650	ns
$t_f$			50	ns
$E_{on}$			12.1	mJ
$E_{off}$			10.5	mJ
$R_{thJC}$				0.22 K/W
$R_{thJS}$	with heatsink compound		0.44	K/W

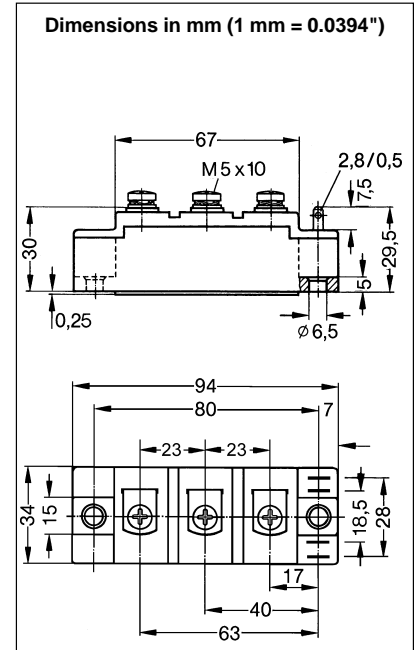

Reverse Diode (FRED)		Characteristic Values ( $T_J = 25^\circ\text{C}$ , unless otherwise specified)		
		min.	typ.	max.
$V_F$	$I_F = 75\text{ A}, V_{GE} = 0\text{ V},$ $I_F = 75\text{ A}, V_{GE} = 0\text{ V}, T_J = 125^\circ\text{C}$		2.2 1.7	2.5 V 1.8 V
$I_F$	$T_C = 25^\circ\text{C}$ $T_C = 80^\circ\text{C}$			150 A 95 A
$I_{RM}$	$I_F = 75\text{ A}, V_{GE} = 0\text{ V}, -di_F/dt = 600\text{ A}/\mu\text{s}$		62	A
$t_{rr}$	$T_J = 125^\circ\text{C}, V_R = 600\text{ V}$		200	ns
$R_{thJC}$				0.45 K/W
$R_{thJS}$	with heatsink compound		0.9	K/W

### Equivalent Circuits for Simulation

#### Conduction

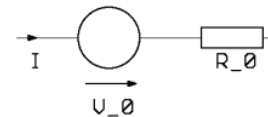

IGBT (typ. at  $V_{GE} = 15\text{ V}; T_J = 125^\circ\text{C}$ )  
 $V_0 = 1.5\text{ V}; R_0 = 13.6\text{ m}\Omega$

Free Wheeling Diode (typ. at  $T_J = 125^\circ\text{C}$ )  
 $V_0 = 1.3\text{ V}; R_0 = 6.5\text{ m}\Omega$

#### Thermal Response

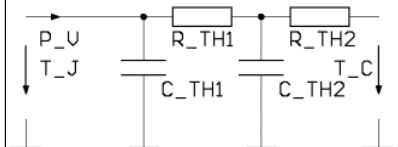

IGBT (typ.)

$C_{th1} = 0.20\text{ J/K}; R_{th1} = 0.218\text{ K/W}$   
 $C_{th2} = 0.47\text{ J/K}; R_{th2} = 0.005\text{ K/W}$

Free Wheeling Diode (typ.)

$C_{th1} = 0.14\text{ J/K}; R_{th1} = 0.443\text{ K/W}$   
 $C_{th2} = 0.26\text{ J/K}; R_{th2} = 0.009\text{ K/W}$

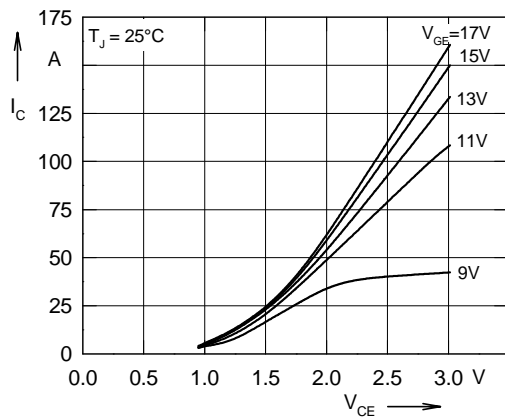

Fig. 1 Typ. output characteristics

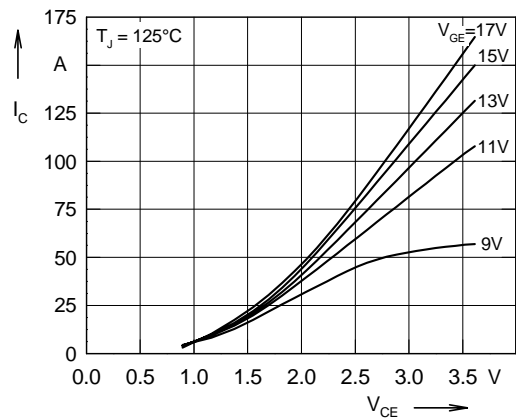

Fig. 2 Typ. output characteristics

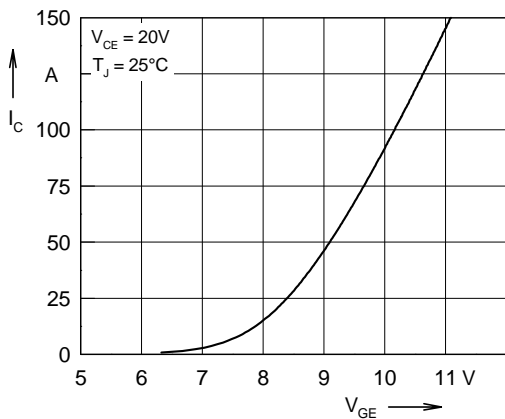

Fig. 3 Typ. transfer characteristics

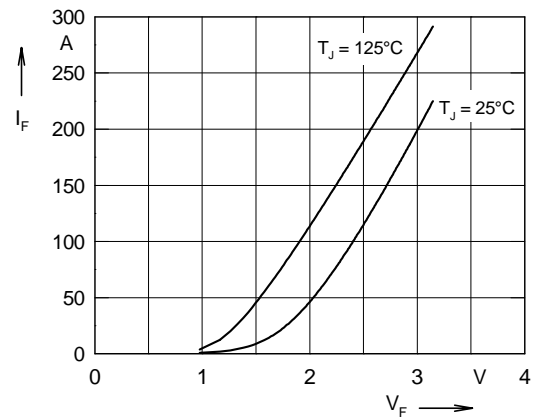

Fig. 4 Typ. forward characteristics of free wheeling diode

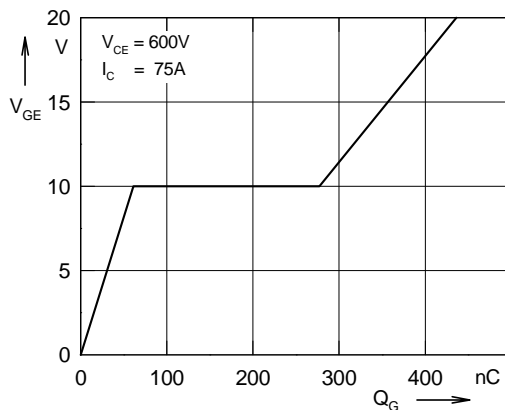

Fig. 5 Typ. turn on gate charge

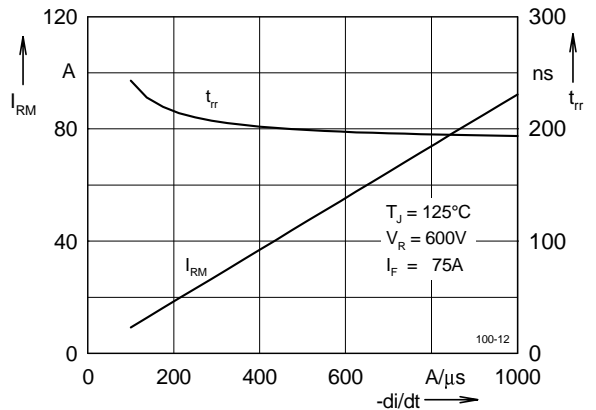

Fig. 6 Typ. turn off characteristics of free wheeling diode

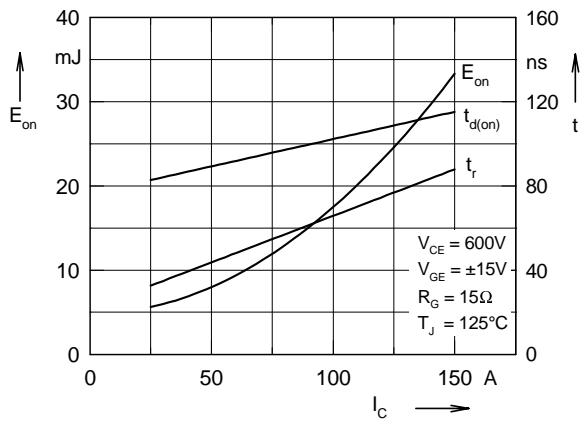

Fig. 7 Typ. turn on energy and switching times versus collector current

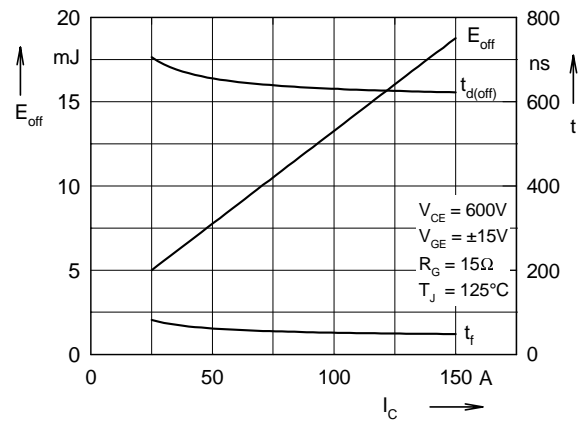

Fig. 8 Typ. turn off energy and switching times versus collector current

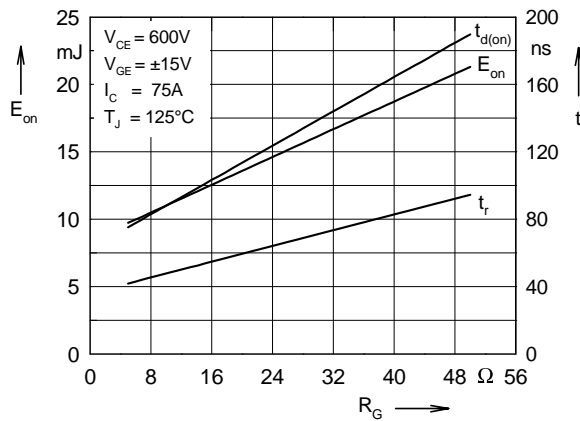

Fig. 9 Typ. turn on energy and switching times versus gate resistor

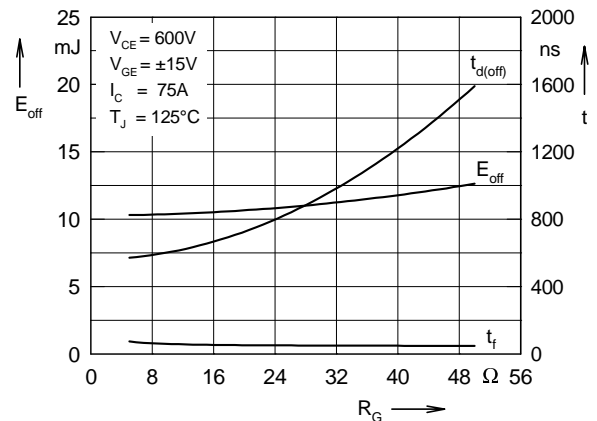

Fig. 10 Typ. turn off energy and switching times versus gate resistor

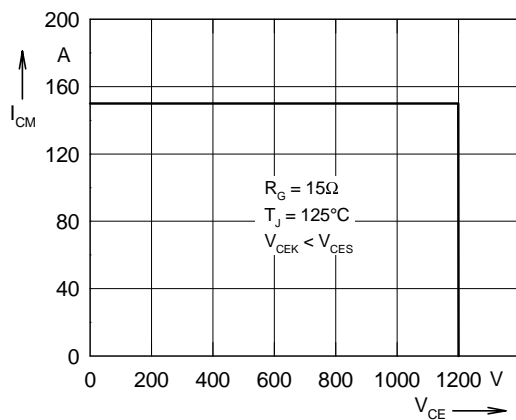

Fig. 11 Reverse biased safe operating area RBSOA

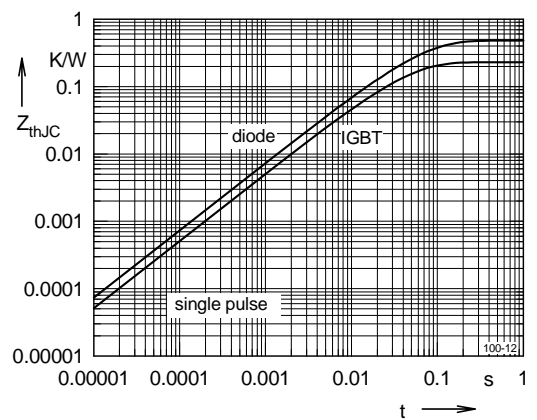

Fig. 12 Typ. transient thermal impedance