

IGBT Modules

Short Circuit SOA Capability

Square RBSOA

$I_{C25} = 90 \text{ A}$
 $V_{CES} = 1200 \text{ V}$
 $V_{CE(sat) \text{ typ.}} = 2.2 \text{ V}$

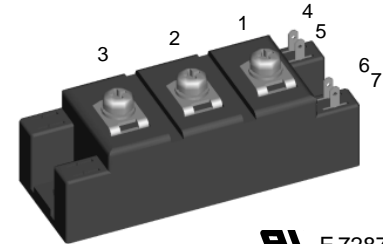
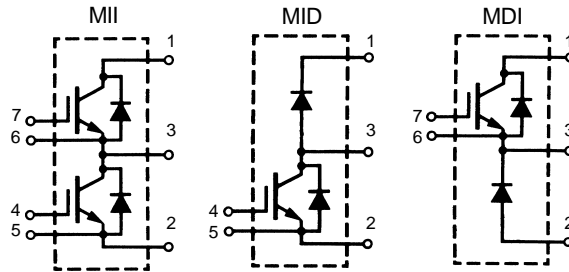

E 72873

Symbol	Conditions	Maximum Ratings	
V_{CES}	$T_J = 25^\circ\text{C to } 150^\circ\text{C}$	1200	V
V_{CGR}	$T_J = 25^\circ\text{C to } 150^\circ\text{C}; R_{GE} = 20 \text{ k}\Omega$	1200	V
V_{GES}	Continuous	± 20	V
V_{GEM}	Transient	± 30	V
I_{C25}	$T_C = 25^\circ\text{C}$	90	A
I_{C80}	$T_C = 80^\circ\text{C}$	60	A
I_{CM}	$T_C = 80^\circ\text{C}, t_p = 1 \text{ ms}$	120	A
t_{SC} (SCSOA)	$V_{GE} = \pm 15 \text{ V}, V_{CE} = V_{CES}, T_J = 125^\circ\text{C}$ $R_G = 22 \Omega$, non repetitive	10	μs
RBSOA	$V_{GE} = \pm 15 \text{ V}, T_J = 125^\circ\text{C}, R_G = 22 \Omega$ Clamped inductive load, $L = 100 \mu\text{H}$	$I_{CM} = 100$ $V_{CEK} \leq V_{CES}$	A
P_{tot}	$T_C = 25^\circ\text{C}$	370	W
T_J		150	$^\circ\text{C}$
T_{stg}		-40 ... +150	$^\circ\text{C}$
V_{ISOL}	50/60 Hz, RMS $t = 1 \text{ min}$ $I_{ISOL} \leq 1 \text{ mA}$ $t = 1 \text{ s}$ Insulating material: Al_2O_3	4000 4800	V~ V~
M_d	Mounting torque (module) (terminals)	2.25-2.75 20-25 2.5-3.7 22-33	Nm lb.in. Nm lb.in.
d_s	Creepage distance on surface	12.7	mm
d_A	Strike distance through air	9.6	mm
a	Max. allowable acceleration	50	m/s^2
Weight	Typical	130 4.6	g oz.

Data according to a single IGBT/FRED unless otherwise stated.

Features

- NPT IGBT technology
- low saturation voltage
- low switching losses
- switching frequency up to 30 kHz
- square RBSOA, no latch up
- high short circuit capability
- positive temperature coefficient for easy paralleling
- MOS input, voltage controlled
- ultra fast free wheeling diodes
- package with DCB ceramic base plate
- isolation voltage 4800 V
- UL registered E72873

Advantages

- space and weight savings
- reduced protection circuits

Typical Applications

- AC and DC motor control
- AC servo and robot drives
- power supplies
- welding inverters

Symbol	Conditions	Characteristic Values ($T_J = 25^\circ\text{C}$, unless otherwise specified)		
		min.	typ.	max.
$V_{(BR)CES}$	$V_{GE} = 0\text{ V}$	1200		V
$V_{GE(th)}$	$I_C = 2\text{ mA}, V_{CE} = V_{GE}$	4.5		6.5 V
I_{CES}	$V_{CE} = V_{CES}$ $T_J = 25^\circ\text{C}$ $T_J = 125^\circ\text{C}$		6	4 mA mA
I_{GES}	$V_{CE} = 0\text{ V}, V_{GE} = \pm 20\text{ V}$			$\pm 200\text{ nA}$
$V_{CE(sat)}$	$I_C = 50\text{ A}, V_{GE} = 15\text{ V}$		2.2	2.7 V
C_{ies}	$V_{CE} = 25\text{ V}, V_{GE} = 0\text{ V}, f = 1\text{ MHz}$		3.3	nF
C_{oes}			0.5	nF
C_{res}			0.22	nF
$t_{d(on)}$	Inductive load, $T_J = 125^\circ\text{C}$ $I_C = 50\text{ A}, V_{GE} = \pm 15\text{ V}$ $V_{CE} = 600\text{ V}, R_G = 22\ \Omega$		100	ns
t_r			70	ns
$t_{d(off)}$			500	ns
t_f			70	ns
E_{on}			7.6	mJ
E_{off}			5.6	mJ
R_{thJC}				0.33 K/W
R_{thJS}	with heatsink compound		0.66	K/W

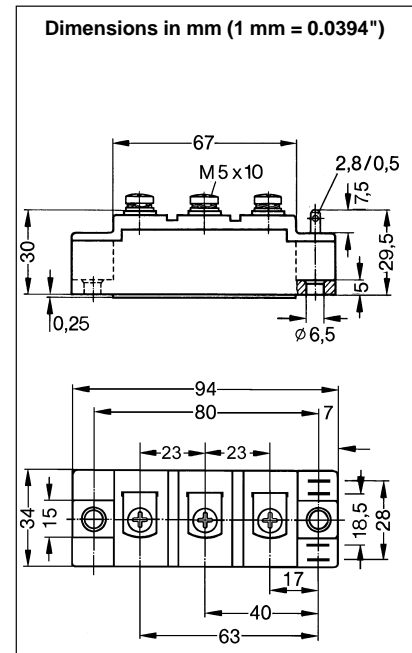

Symbol	Conditions	Characteristic Values ($T_J = 25^\circ\text{C}$, unless otherwise specified)		
		min.	typ.	max.
V_F	$I_F = 50\text{ A}, V_{GE} = 0\text{ V},$ $I_F = 50\text{ A}, V_{GE} = 0\text{ V}, T_J = 125^\circ\text{C}$		2.2 1.8	2.5 V 1.9 V
I_F	$T_C = 25^\circ\text{C}$ $T_C = 80^\circ\text{C}$			100 A 60 A
I_{RM}	$I_F = 50\text{ A}, V_{GE} = 0\text{ V}, -di_F/dt = 400\text{ A}/\mu\text{s}$		40	A
t_{rr}	$T_J = 125^\circ\text{C}, V_R = 600\text{ V}$		200	ns
R_{thJC}				0.66 K/W
R_{thJS}	with heatsink compound		1.32	K/W

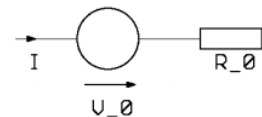
Equivalent Circuits for Simulation
Conduction

IGBT (typ. at $V_{GE} = 15\text{ V}; T_J = 125^\circ\text{C}$)
 $V_0 = 1.5\text{ V}; R_0 = 20.1\text{ m}\Omega$

Free Wheeling Diode (typ. at $T_J = 125^\circ\text{C}$)
 $V_0 = 1.3\text{ V}; R_0 = 10.8\text{ m}\Omega$

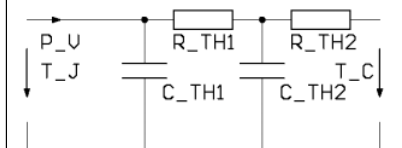
Thermal Response

IGBT (typ.)

$C_{th1} = 0.13\text{ J/K}; R_{th1} = 0.323\text{ K/W}$
 $C_{th2} = 0.32\text{ J/K}; R_{th2} = 0.008\text{ K/W}$

Free Wheeling Diode (typ.)

$C_{th1} = 0.10\text{ J/K}; R_{th1} = 0.645\text{ K/W}$
 $C_{th2} = 0.18\text{ J/K}; R_{th2} = 0.013\text{ K/W}$

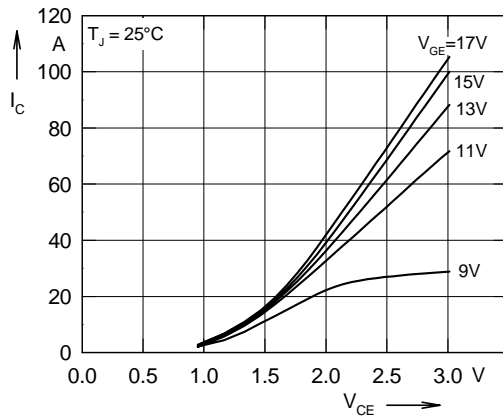

Fig. 1 Typ. output characteristics

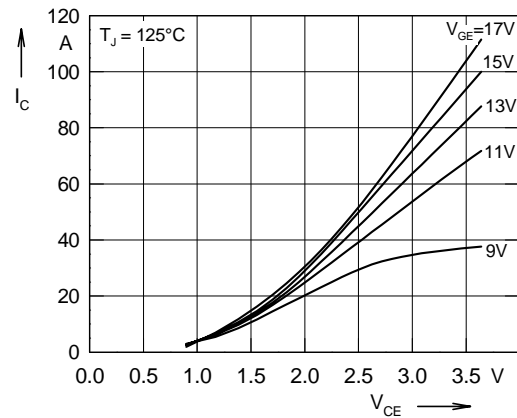

Fig. 2 Typ. output characteristics

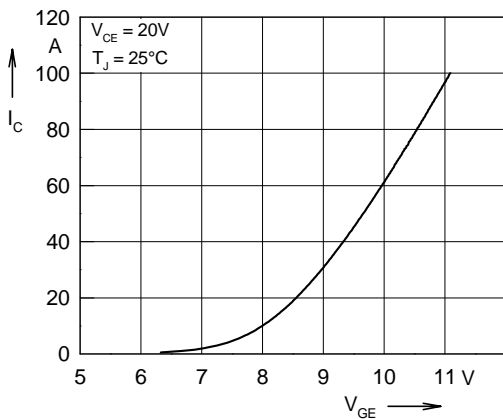

Fig. 3 Typ. transfer characteristics

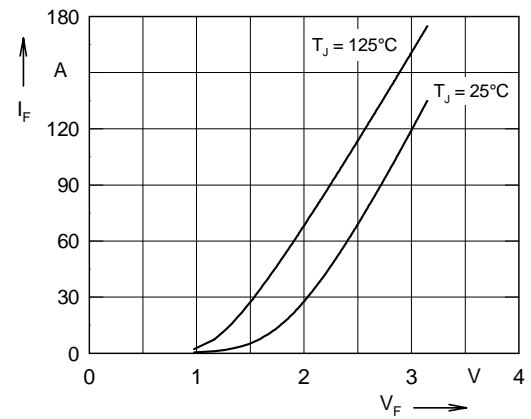

Fig. 4 Typ. forward characteristics of free wheeling diode

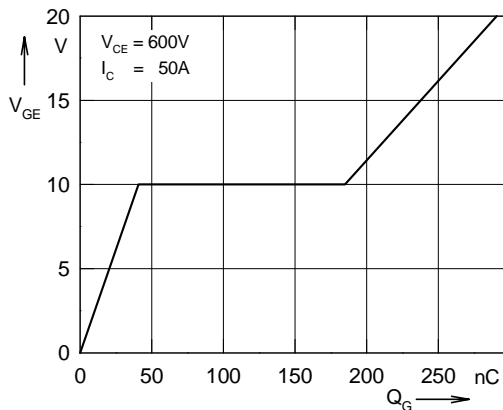

Fig. 5 Typ. turn on gate charge

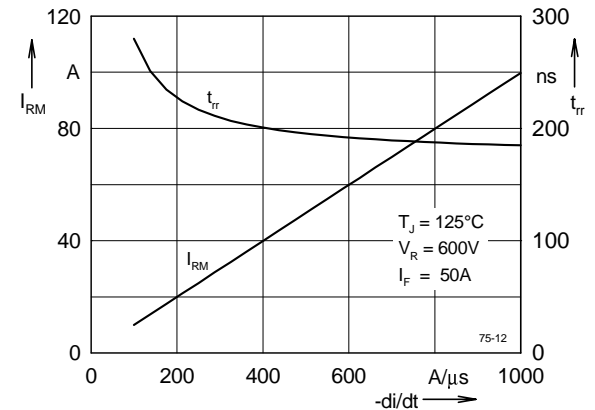

Fig. 6 Typ. turn off characteristics of free wheeling diode

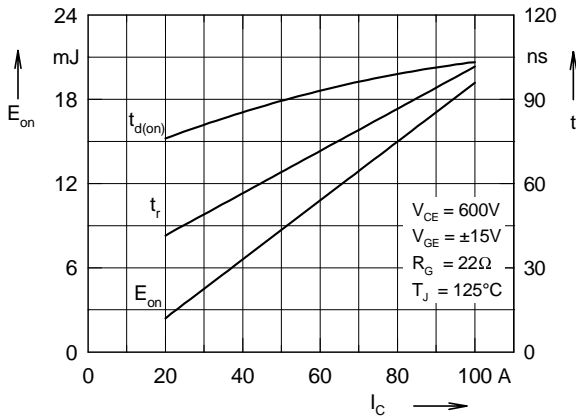

Fig. 7 Typ. turn on energy and switching times versus collector current

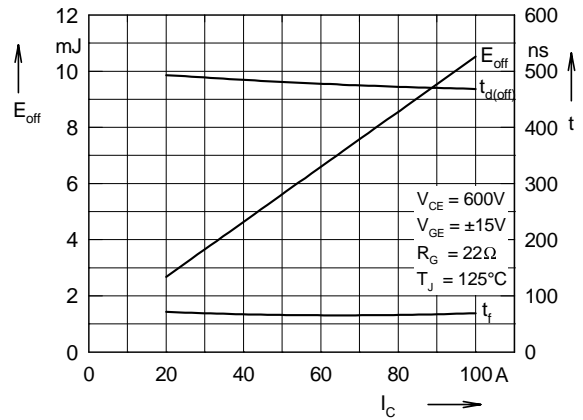

Fig. 8 Typ. turn off energy and switching times versus collector current

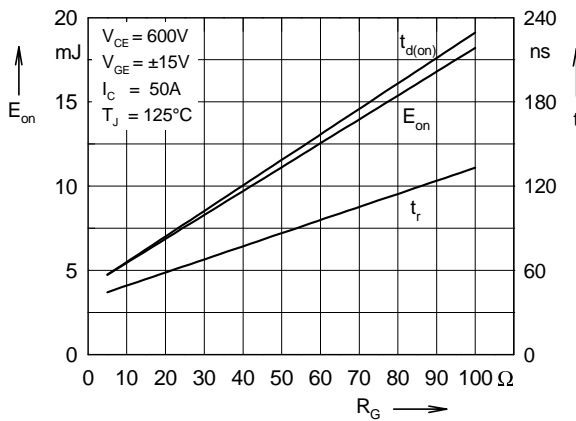

Fig. 9 Typ. turn on energy and switching times versus gate resistor

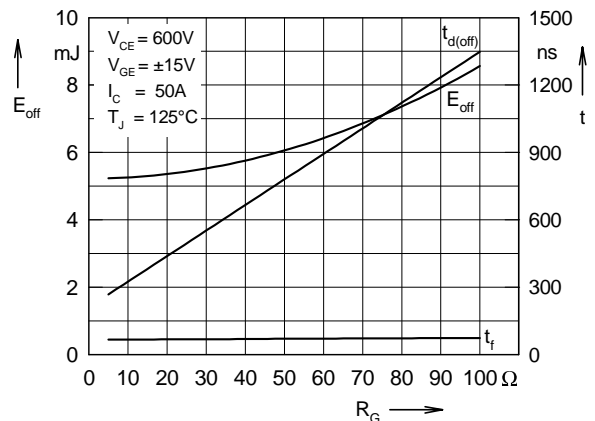

Fig.10 Typ. turn off energy and switching times versus gate resistor

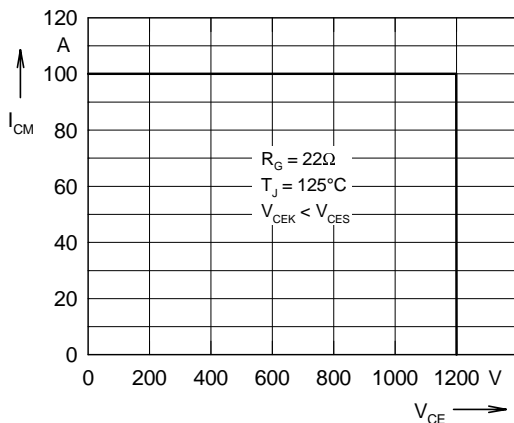

Fig. 11 Reverse biased safe operating area RBSOA

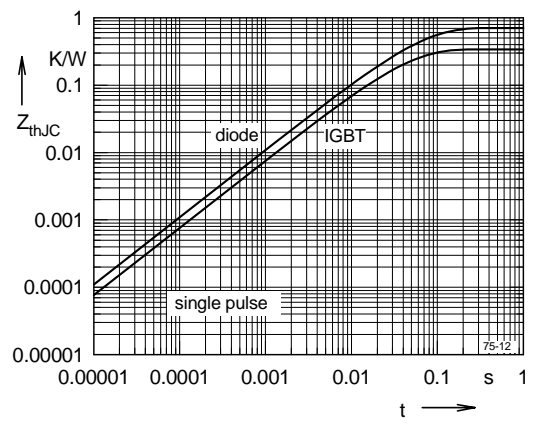

Fig. 12 Typ. transient thermal impedance