

APEM COMPONENTS LIMITED



A P E M

Designed and manufactured in the UK

Illuminated pushbuttons and indicators,
Keylock, Lever and Emergency Stop Switches



Certificate No: FM 67874

APEM designs and manufactures three product lines: miniature and industrial switches, switch panels for professional applications and specific assemblies.

APEM rank amongst the world's largest manufacturers of both miniature and industrial switches with manufacturing sites in the United Kingdom, France and the United States.

With several million part number variants corresponding to over 250 product families, APEM can meet all the requirements of miniature, sub-miniature and industrial switch markets.

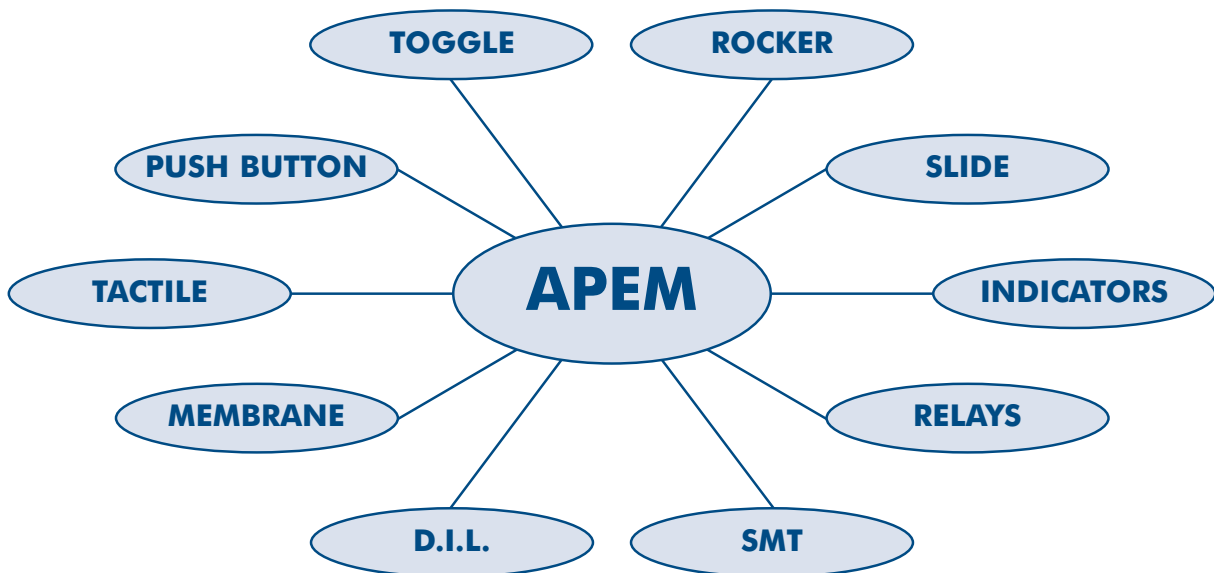

A01 SERIES

INDUSTRIAL CONTROLS

Panel cut-out Ø16MM



	Page	Contents
	5	A01 - A02 Series Specifications
	6	Illuminated or non-illuminated pushbutton switches
	7	Indicators
	8	Rotary lever switches
	9	Keylock switches
	10	Emergency stop switches
NEW	11	Emergency stop enclosure switches
	12	Mushroom head pushbutton switches
NEW	13	Custom engraved aluminium pushbutton switches
	14	Accessories
	15	Accessories
	16	Installation/accessories

A02 SERIES/A03 SERIES/PUSH-PULL SERIES

INDUSTRIAL CONTROLS
Panel cut-out Ø22-Ø30MM



Page	Contents
17	Illuminated or non-illuminated pushbutton switches
18	Metal bezel pushbuttons and indicators
19	Flush mounting pushbuttons and indicators
20	Indicators
21	Rotary lever switches
22	Keylock switches
23	Emergency stop switches
24	Mushroom head pushbutton switches
25	Installation/accessories
NEW	26 A03 Series range of pushbuttons/indicators
NEW	27 Push-pull switches
NEW	28 APEM special assemblies

A01 - A02 SERIES

INDUSTRIAL CONTROLS

Distinctive features

A01 and A02 Series are designed and manufactured in the United Kingdom

The A01 and A02 series offer ranges of:

- pushbutton switches, illuminated or not
 - indicators
 - 2 or 3 position keylock switches
 - 2 or 3 position rotary lever switches
 - emergency stop switches
- with rectangular, square or round operators.

- Environmental protection : IP65
- Modular construction
- Electrical life : 50.000 cycles min.
- Screen engraving or insertable legends on request
- Approvals



UL 1054



BS RIA 20
Shock & Vibration



VDE



EN 61058



Sub-assembly

For single part number assemblies please contact APEM Components

A01/A1/A03 Series

• Panel cut-out :
– Ø 16mm (.630)
– flush mount : round Ø 22mm (.866)
– flush mount : rectangular 20.60 x 26.70mm (.811 x 1.051)
– flush mount : square 20.60 x 20.60 (.811 x .811)
A1 – flush mount : round Ø 22mm (.866)
A03 – round or square: Ø 22mm (.866)
– flush mount : Ø 30mm (1.378)
• 1, 2, 3 and 4 poles
• Solder lug/quick-connect terminals
• Contacts : silver, gold plated
• Current/voltage rating :
6A 250VAC max. - 10mA 5VAC min.
• Lamp : filament, neon or multi-chip LED

A02 Series



• Panel cut-out :
– round or square : Ø 22mm (.866)
– rectangular : 29,5 x 21,5mm (1.160 x .846)
– flush mount : Ø30mm (1.378)
• 1 and 2 poles
• Screw terminals (optional : quick connect terminals)
• Contacts : silver
• Current/voltage rating :
12A 380VAC - 16A 250VAC max.
25mA 5VAC min.
• Lamp : filament, neon, multi-chip LED
or special multi-LED assembly
For back of panel safety, this series has a unique covered cable connection arrangement. See page 25.

A01 - A02 SERIES

INDUSTRIAL CONTROLS

Specifications

ELECTRICAL SPECIFICATIONS

	A01/A1/A03	A02
• Function :	Momentary or maintained action	Momentary or maintained action
• Current/voltage rating :	10mA 5VAC min. 6A 250VAC max. 6A/12VDC max.	25mA 5VAC min. 12A 380VAC - 16A 250VAC max. 12A/12VDC max.
• Contact gap :	>1mm (.039)	Double break 2 x 1,5mm (.059)
• Initial contact resistance :	10mΩ max. at 1A 4VDC	10mΩ max. at 1A 4VDC
• Insulation resistance :	50 MΩ min.	50 MΩ min.
• Dielectric strength :	750V between open contacts 5KV live to accessible	2KV between open contacts 4KV live to accessible
• Electrical life :	50.000 cycles min.	50.000 cycles min.
• Insulation :	Class 2	Class 2
• Lamp life :	LED : 60.000 h min. to 75% relative luminosity - Filament : approx. 5.000h Neon : approx. 10.000 h	LED : 60.000 h min. to 75% relative luminosity - Filament : approx. 5.000h Neon : approx. 10.000 h
• Lamp circuit diagrams	 	 

GENERAL SPECIFICATIONS

	A01/A1/A03	A02
• Min. mechanical life :	Pushbutton momentary : 1 million cycles Pushbutton maintained : 100.000 cycles Keylock and rotary : 100.000 cycles	Pushbutton momentary : 1 million cycles Pushbutton maintained : 100.000 cycles Keylock and rotary : 100.000 cycles
• Operating temperature :	-20°C to +55°C	-20°C to +85°C
• Solder heat resistance : (IEC 68-2-20Tb, method 2)	350°C, 5 sec.	350°C, 5 sec.
• Degree of environmental protection (IEC 529)	IP 65 front of panel IP 40 back of panel	IP 65 front of panel IP 40 back of panel
• Lamps :	Midget Grooved T1 3/4 filament, multi-chip LED or neon	Midget Grooved T1 3/4 filament, multi-chip LED or neon Special multi-LED assembly
• Switch terminals :	Solder/quick-connect 2,8mm (.110)	M3 screws - wire 2 x 0,75mm 2 max.
• Lamp terminals :	Solder/quick-connect 2,8mm (.110)	M3 screws Flexible wire 2 x 2,5mm ² max. Rigid wire 4mm ² max

For screen engraving or film legends, consult factory. For approved models consult APEM.

A01 SERIES

ILLUMINATED OR NON-ILLUMINATED PUSHBUTTON SWITCHES

Panel cut-out Ø16 (.630)

A pushbutton assembly requires:

screen + lamp (if illuminated) + operator + switchblock

To order these elements, select desired model numbers from tables below.

Example: IP65 rectangular pushbutton, single pole, maintained, red screen and 12V red LED = A0161B, A0142M1, A0101X and A0151B

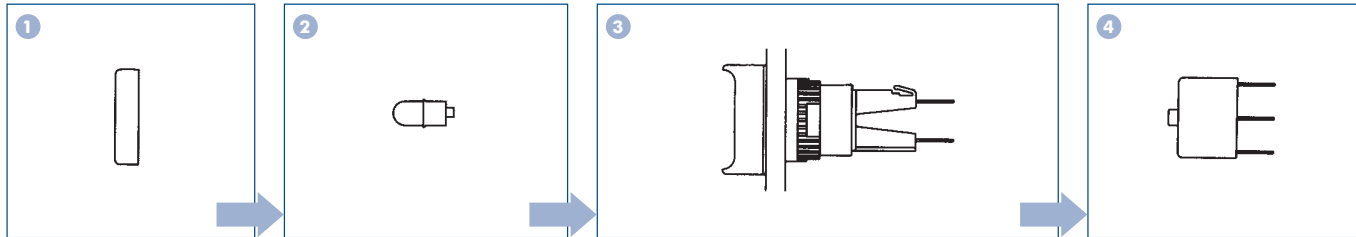
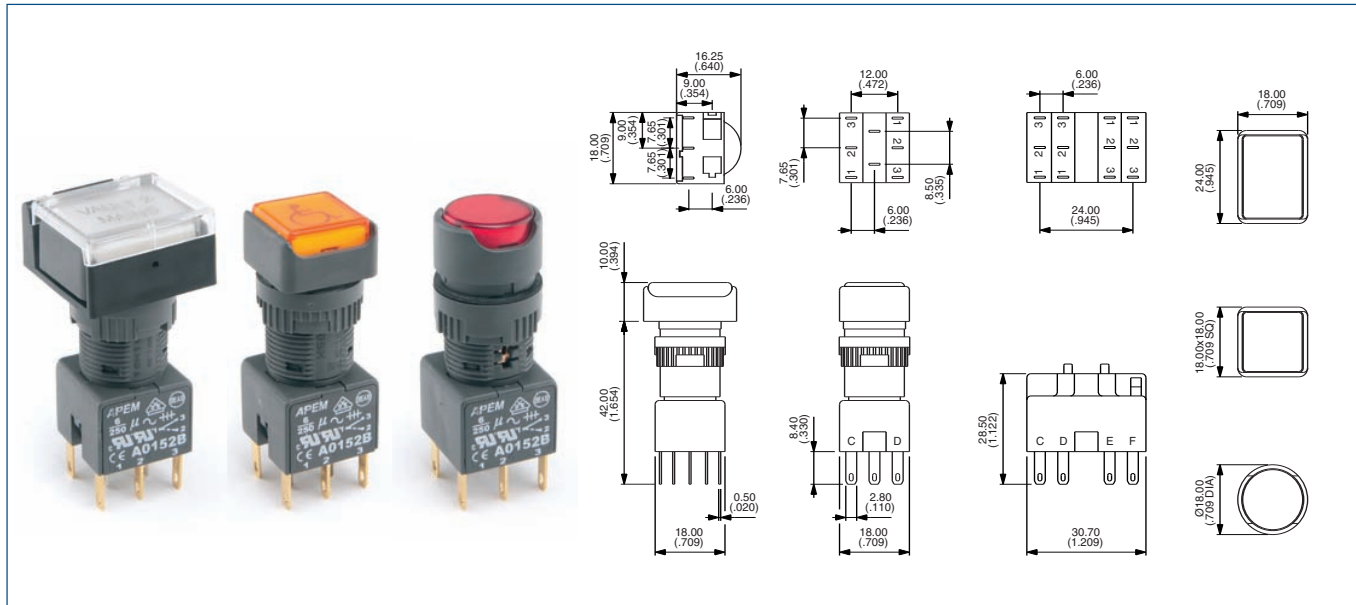
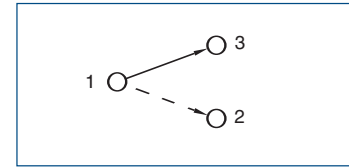

Screen

Bezel	Colour	Part No
<input type="checkbox"/>	black	A0161A
<input type="checkbox"/>	red	A0161B
<input type="checkbox"/>	amber	A0161C
<input type="checkbox"/>	yellow	A0161D
<input type="checkbox"/>	green	A0161E
<input type="checkbox"/>	blue	A0161F
<input type="checkbox"/>	clear	A0161G
<input type="checkbox"/>	white	A0161J
<input type="checkbox"/>	black	A0162A
<input type="checkbox"/>	red	A0162B
<input type="checkbox"/>	amber	A0162C
<input type="checkbox"/>	yellow	A0162D
<input type="checkbox"/>	green	A0162E
<input type="checkbox"/>	blue	A0162F
<input type="checkbox"/>	clear	A0162G
<input type="checkbox"/>	white	A0162J
<input type="checkbox"/>	black	A0163A
<input type="checkbox"/>	red	A0163B
<input type="checkbox"/>	amber	A0163C
<input type="checkbox"/>	yellow	A0163D
<input type="checkbox"/>	green	A0163E
<input type="checkbox"/>	blue	A0163F
<input type="checkbox"/>	clear	A0163G
<input type="checkbox"/>	white	A0163J

Lamp

Lamp	Voltage	Part No
Filament	6.3V	A0141A
Filament	14V	A0141B
Filament	28V	A0141C
Filament	36V	A0141D
Filament	48V	A0141E
Filament	60V	A0141F
Neon	110V	A0143G
Neon	220V	A0143H
LED	6V red	A0142L1
LED	6V green	A0142L2
LED	6V amber	A0142L3
LED	12V red	A0142M1
LED	12V green	A0142M2
LED	12V amber	A0142M3
LED	12V blue	A0142M4
LED	12V white	A0142M5
LED	24V red	A0142N1
LED	24V green	A0142N2
LED	24V amber	A0142N3
LED	24V blue	A0142N4
LED	24V white	A0142N5
LED	48V red	A0142P1
LED	48V green	A0142P2
LED	48V amber	A0142P3

Operator

Pole	Bezel	Description	Part No
1 or 2	<input type="checkbox"/>	llum, momentary	A0101Y
1 or 2	<input type="checkbox"/>	llum, maintained	A0101X
1 or 2	<input type="checkbox"/>	Non-illum, momentary	A0102Y
1 or 2	<input type="checkbox"/>	Non-illum, maintained	A0102X
3 or 4	<input type="checkbox"/>	llum, momentary	A0103Y
3 or 4	<input type="checkbox"/>	llum, maintained	A0103X
3 or 4	<input type="checkbox"/>	Non-illum, momentary	A0104Y
3 or 4	<input type="checkbox"/>	Non-illum, maintained	A0104X
1 or 2	<input type="checkbox"/>	llum, momentary	A0105Y
1 or 2	<input type="checkbox"/>	llum, maintained	A0105X
1 or 2	<input type="checkbox"/>	Non-illum, momentary	A0106Y
1 or 2	<input type="checkbox"/>	Non-illum, maintained	A0106X
3 or 4	<input type="checkbox"/>	llum, momentary	A0107Y
3 or 4	<input type="checkbox"/>	llum, maintained	A0107X
3 or 4	<input type="checkbox"/>	Non-illum, momentary	A0108Y
3 or 4	<input type="checkbox"/>	Non-illum, maintained	A0108X
1 or 2	<input type="checkbox"/>	llum, momentary	A0109Y
1 or 2	<input type="checkbox"/>	llum, maintained	A0109X
1 or 2	<input type="checkbox"/>	Non-illum, momentary	A0110Y
1 or 2	<input type="checkbox"/>	Non-illum, maintained	A0110X
3 or 4	<input type="checkbox"/>	llum, momentary	A0111Y
3 or 4	<input type="checkbox"/>	llum, maintained	A0111X
3 or 4	<input type="checkbox"/>	Non-illum, momentary	A0112Y
3 or 4	<input type="checkbox"/>	Non-illum, maintained	A0112X

Switch block

No of poles	Part No
Single pole	A0151B
Double pole	A0152B
Three pole	A0155B
Four pole	A0153B

Unsealed switches (IP40):
add '01' to end of operator model number

Screen engraving/insertable legends:
contact APEM Components

Bi-colour LEDs optional

Bezel: rectangular square round. 'llum' - illuminated, 'Non-illum' - non illuminated

A01 SERIES INDICATORS

Panel cut-out Ø16 (.630)

An indicator assembly requires:

screen + lamp + operator

To order these elements, select desired model numbers from tables below.

Example: IP65 rectangular indicator with red screen and 12V red LED = A0161B, A0142M1 and A0171

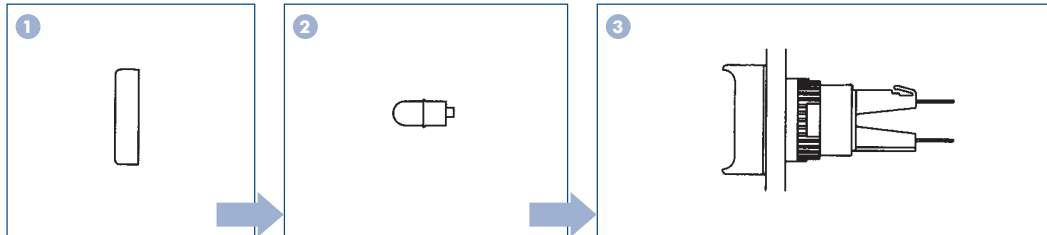
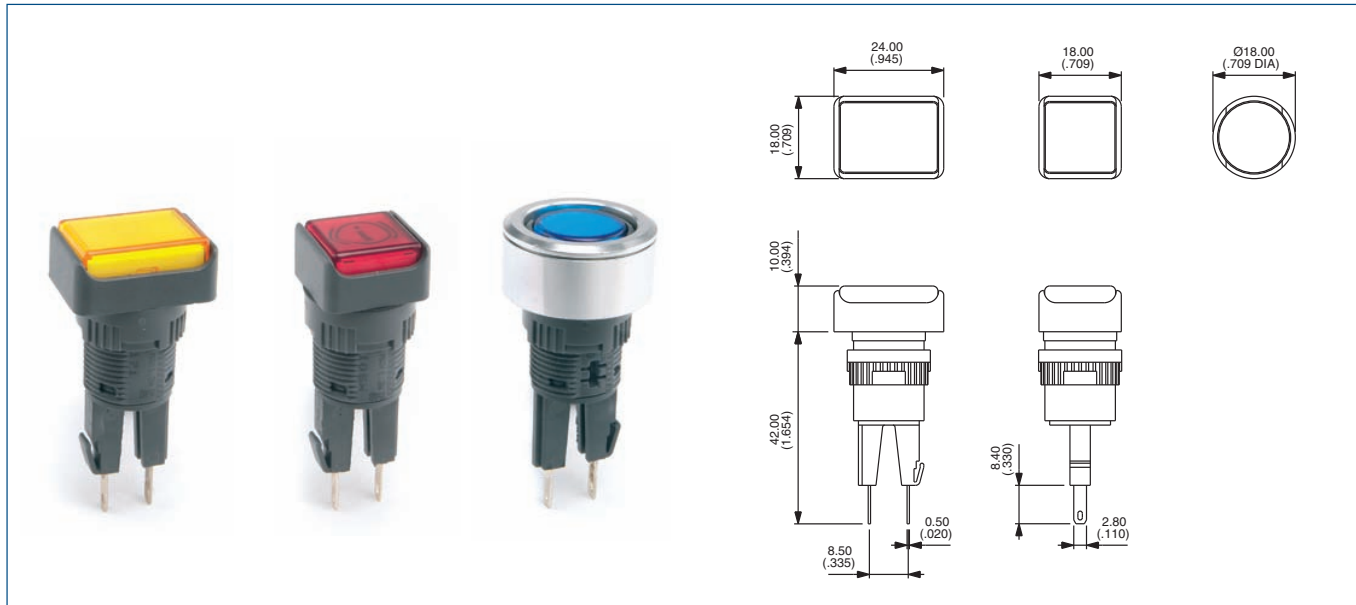

Screen

Bezel	Colour	Part No
<input type="checkbox"/>	black	A0161A
<input type="checkbox"/>	red	A0161B
<input type="checkbox"/>	amber	A0161C
<input type="checkbox"/>	yellow	A0161D
<input type="checkbox"/>	green	A0161E
<input type="checkbox"/>	blue	A0161F
<input type="checkbox"/>	clear	A0161G
<input type="checkbox"/>	white	A0161J
<input type="checkbox"/>	black	A0162A
<input type="checkbox"/>	red	A0162B
<input type="checkbox"/>	amber	A0162C
<input type="checkbox"/>	yellow	A0162D
<input type="checkbox"/>	green	A0162E
<input type="checkbox"/>	blue	A0162F
<input type="checkbox"/>	clear	A0162G
<input type="checkbox"/>	white	A0162J
<input type="radio"/>	black	A0163A
<input type="radio"/>	red	A0163B
<input type="radio"/>	amber	A0163C
<input type="radio"/>	yellow	A0163D
<input type="radio"/>	green	A0163E
<input type="radio"/>	blue	A0163F
<input type="radio"/>	clear	A0163G
<input type="radio"/>	white	A0163J

Lamp

Lamp	Voltage	Part No
Filament	6.3V	A0141A
Filament	14V	A0141B
Filament	28V	A0141C
Filament	36V	A0141D
Filament	48V	A0141E
Filament	60V	A0141F
Neon	110V	A0143G
Neon	220V	A0143H
LED	6V red	A0142L1
LED	6V green	A0142L2
LED	6V amber	A0142L3
LED	12V red	A0142M1
LED	12V green	A0142M2
LED	12V amber	A0142M3
LED	12V blue	A0142M4
LED	12V white	A0142M5
LED	24V red	A0142N1
LED	24V green	A0142N2
LED	24V amber	A0142N3
LED	24V blue	A0142N4
LED	24V white	A0142N5
LED	48V red	A0142P1
LED	48V green	A0142P2
LED	48V amber	A0142P3

Operator

Bezel	Description	Part No
<input type="checkbox"/>	Indicator	A0171
<input type="checkbox"/>	Indicator	A0172
<input type="radio"/>	Indicator	A0173

Unsealed switches (IP40):
add '01' to end of **operator** model number

Screen engraving/insertable legends:
contact **APEM** Components

Bezel: rectangular square round.

A01 SERIES

ROTARY LEVER SWITCHES

Panel cut-out Ø16 (.630)

A rotary level switch assembly requires:

operator + switchblock

To order these elements, select desired model numbers from tables below.

Example: IP65 rectangular rotary switch with long lever, single pole, 2 positions maintained = A019101 and A0151B

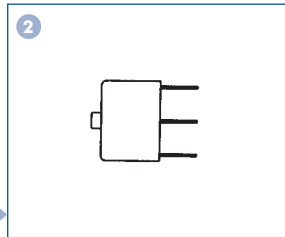
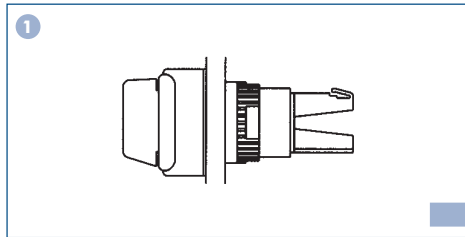
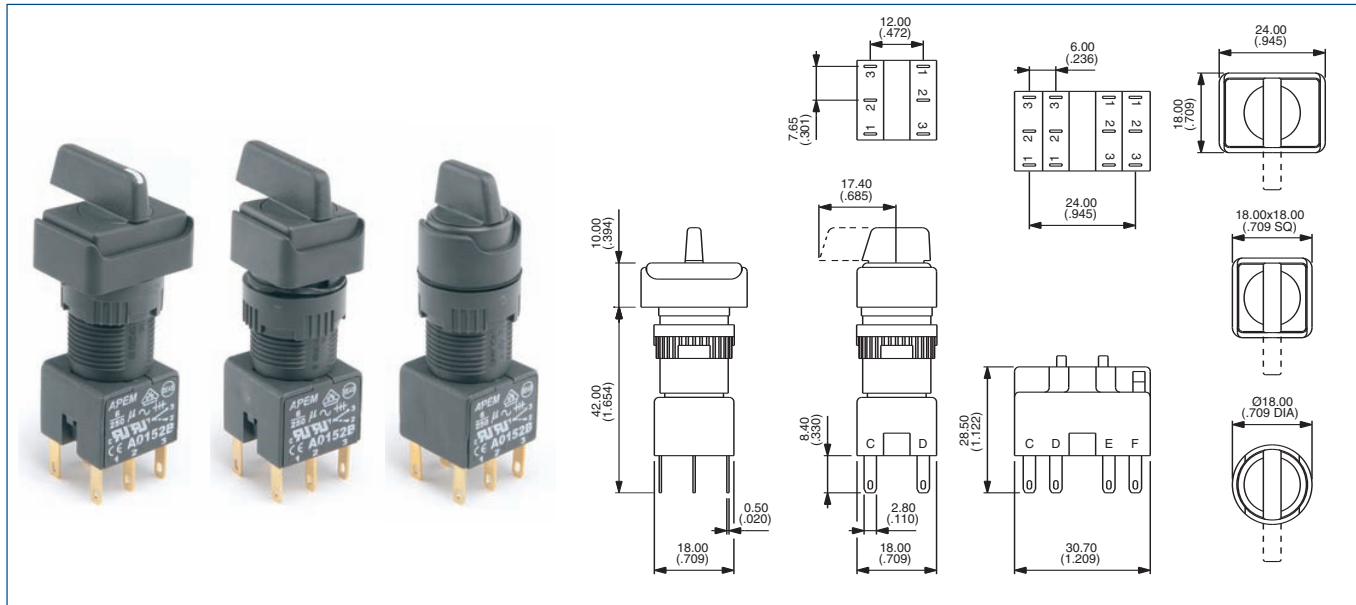
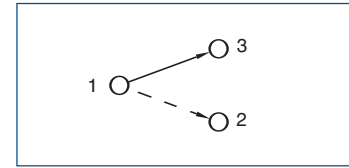

Operator

Pole	Bezel	Description	Short lever	Long lever
1 or 2	□	2 pos. maintained	A019201	A019101
1 or 2	□	2 pos. momentary	A019202	A019102
3 or 4	□	2 pos. maintained	A019203	A019103
3 or 4	□	2 pos. momentary	A019204	A019104
1 or 2	□	3 pos. maintained	A019205	A019105
1 or 2	□	3 pos. momentary	A019206	A019106
1 or 2	□	3 pos. mainL, momR	A019207	A019107
1 or 2	□	3 pos. momL, mainR	A019208	A019108
1 or 2	□	2 pos. maintained	A019401	A019301
1 or 2	□	2 pos. momentary	A019402	A019302
3 or 4	□	2 pos. maintained	A019403	A019303
3 or 4	□	2 pos. momentary	A019404	A019304
1 or 2	□	3 pos. maintained	A019405	A019305
1 or 2	□	3 pos. momentary	A019406	A019306
1 or 2	□	3 pos. mainL, momR	A019407	A019307
1 or 2	□	3 pos. momL, mainR	A019408	A019308
1 or 2	○	2 pos. maintained	A019601	A019501
1 or 2	○	2 pos. momentary	A019602	A019502
3 or 4	○	2 pos. maintained	A019603	A019503
3 or 4	○	2 pos. momentary	A019604	A019504
1 or 2	○	3 pos. maintained	A019605	A019505
1 or 2	○	3 pos. momentary	A019606	A019506
1 or 2	○	3 pos. mainL, momR	A019607	A019507
1 or 2	○	3 pos. momL, mainR	A019608	A019508

Switch block

No of poles	Part No
Single pole	A0151B
Double pole	A0152B
Three pole	A0155B
Four pole	A0153B

• Note: 3/4 pole switch block for use only with 2 position rotary lever

Lever Positions

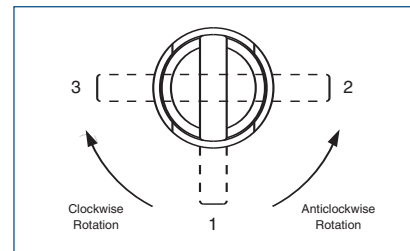

Lever Rotation – 2 position switches

The model numbers shown are for switches with anticlockwise lever rotation.

For clockwise rotation, replace:

01	with	09
02	with	10
03	with	11
04	with	12

at the end of the model number

Optional engraving on lever end add "WL" to the end of the part number.

Bezel: □ rectangular □ square ○ round. 'pos' - position, 'mainL' - maintained left 'momR' - momentary right, etc

A01 SERIES

KEYLOCK SWITCHES

Panel cut-out Ø16 (.630)

An keylock assembly requires:

operator + switchblock

To order these elements, select desired model numbers from tables below.

Example: IP65 rectangular keyswitch, single pole, 2 positions maintained = A018101 and A0151B

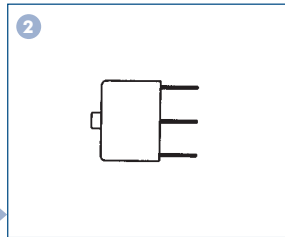
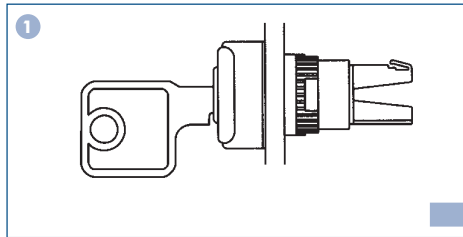
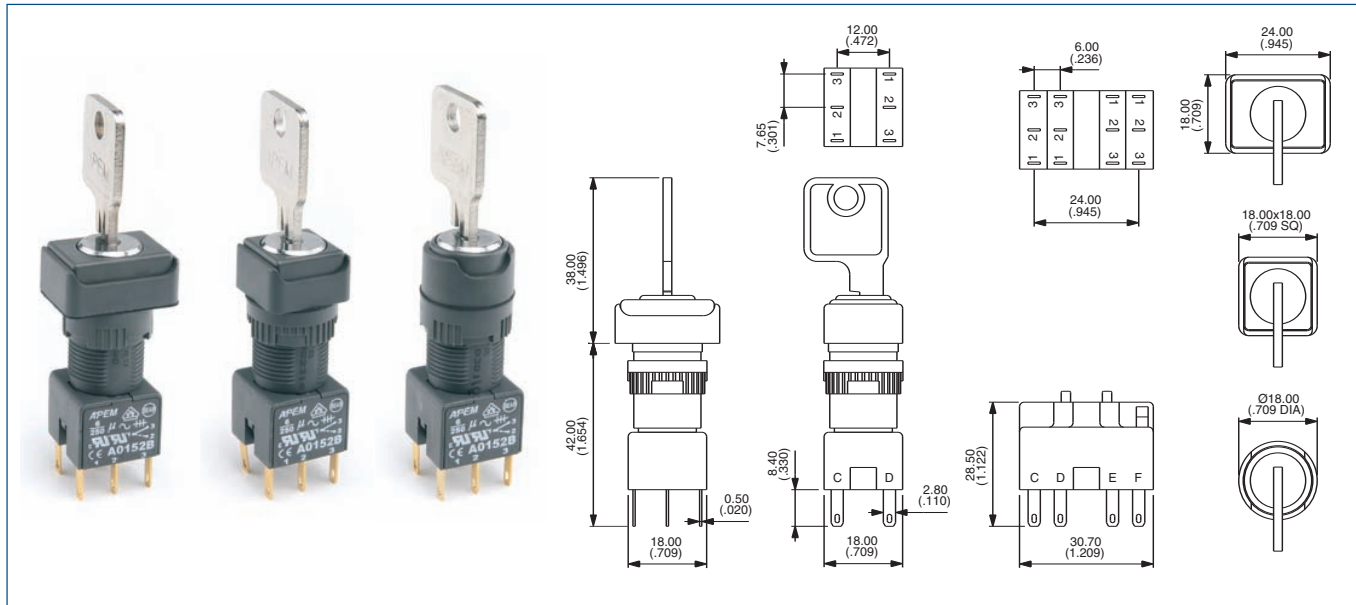
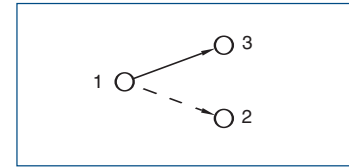

Operator

Pole	Bezel	Description	Part No.	Key removable
1 or 2	□	2 pos. maintained	A018101	A-C
1 or 2	□	2 pos. momentary	A018102	A
3 or 4	□	2 pos. maintained	A018103	A-C
3 or 4	□	2 pos. momentary	A018104	A
1 or 2	□	3 pos. maintained	A018105	A-B-C
1 or 2	□	3 pos. momentary	A018106	A
1 or 2	□	3 pos. mainL, momR	A018107	A-B
1 or 2	□	3 pos. momL, mainR	A018108	A-C
1 or 2	□	2 pos. maintained	A018201	A-C
1 or 2	□	2 pos. momentary	A018202	A
3 or 4	□	2 pos. maintained	A018203	A-C
3 or 4	□	2 pos. momentary	A018204	A
1 or 2	□	3 pos. maintained	A018205	A-B-C
1 or 2	□	3 pos. momentary	A018206	A
1 or 2	□	3 pos. mainL, momR	A018207	A-B
1 or 2	□	3 pos. momL, mainR	A018208	A-C
1 or 2	○	2 pos. maintained	A018301	A-C
1 or 2	○	2 pos. momentary	A018302	A
3 or 4	○	2 pos. maintained	A018303	A-C
3 or 4	○	2 pos. momentary	A018304	A
1 or 2	○	3 pos. maintained	A018305	A-B-C
1 or 2	○	3 pos. momentary	A018306	A
1 or 2	○	3 pos. mainL, momR	A018307	A-B
1 or 2	○	3 pos. momL, mainR	A018308	A-C

Switch block

No of poles	Part No
Single pole	A0151B
Double pole	A0152B
Three pole	A0155B
Four pole	A0153B

Key Positions

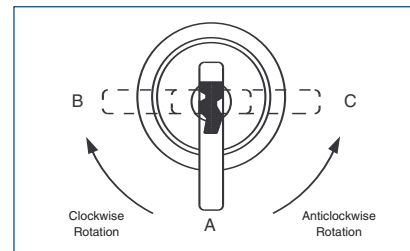

Key Rotation – 2 position switches

The model numbers shown are for switches with anticlockwise key rotation.

For clockwise rotation, replace:

01	with	25
02	with	24
03	with	27
04	with	28

at the end of the model number

- Non-removable key positions: contact APEM components
- 2 standard keys are supplied
- 20 key barrel types available from stock
- For on-on-on function contact APEM components
- Note: 3/4 pole switch block for use only with 2 position key switches

Bezel: □ rectangular □ square ○ round. 'pos' - position, 'mainL' - maintained left 'momR' - momentary right, etc

A01 SERIES

EMERGENCY STOP SWITCHES

Panel cut-out Ø16 (.630)

- Prominent Ø 24mm (.944) or optional Ø 40mm (1.575) dia. red mushroom actuator
- Highly reliable positive break switch
- Push to shut off switch, twist to reset to ON

An emergency stop switch assembly requires:

operator + switch block
 To order specify with single pole or double pole positive break switch block.
 Approved to UL1054/EN 60947-5-1

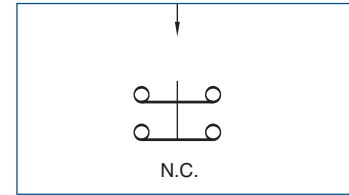

General Specifications

Min. Mechanical Life	: 6050 cycles (6 cycles per minute)
Operating Force	: 16N – 0.1Nm
Operating Temperature	: -20°C to +55°C
Solder Heat Resistance	: 350°C, 5 secs (IEC 68-2-2-20Tb, method 2)
Degree of Environmental Protection (IEC 529)	: IP65 front of panel IP40 back of panel
Switch Terminals	: Solder/quick-connect 2.8mm (.110) (IEC 68-2-20)

Electrical Specifications

Current/Voltage rating	: 1.5A 250 VAC AC-15
Contact Gap	: > 3mm
Dielectric test voltage	: 2900V
Electrical Life	: > 6050

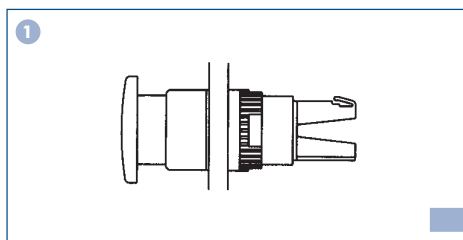
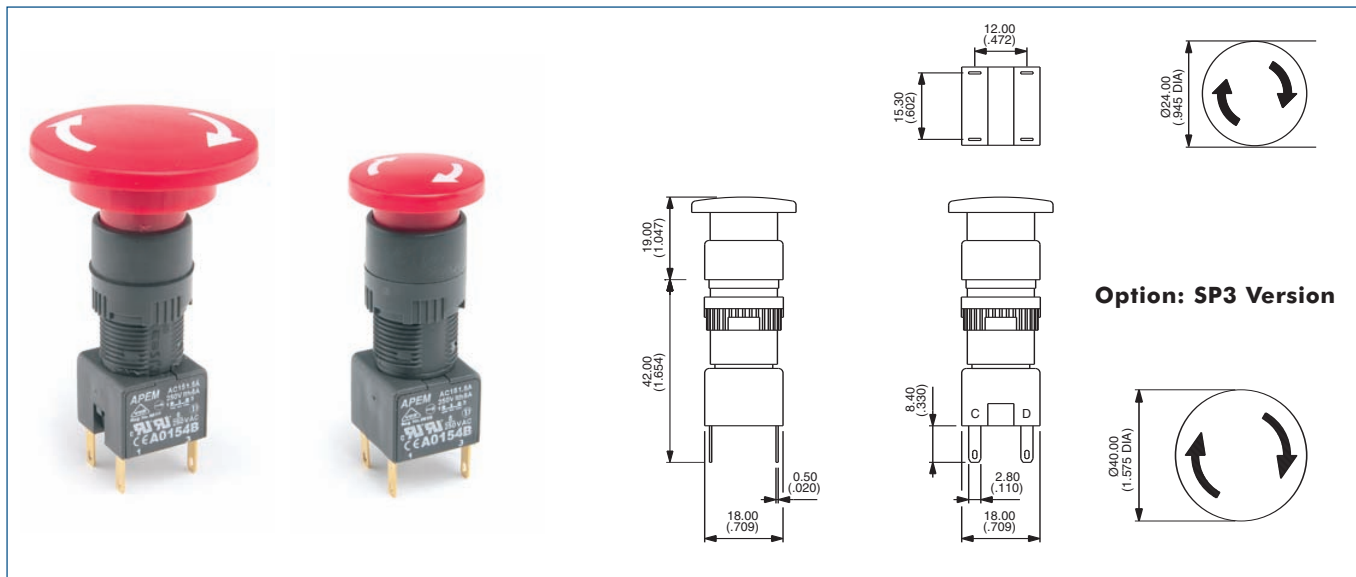

Operator

Bezel	Description	Part No
●	Emergency stop	A01ES
Option		
40Ømm	Emergency stop	A01ES SP3

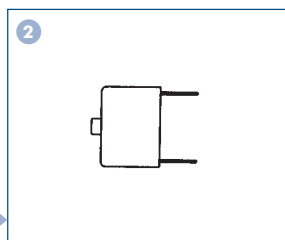

Switch block

No of poles	Part No
Single pole	A0150B
Double pole	A0154B

Accessories



60Ø Self Adhesive Label

Description	Part No
Yellow label with text	A01YL1
Yellow label	A01YL2

A01 SERIES

EMERGENCY STOP SWITCHES/MUSHROOM HEAD PUSHBUTTON SWITCHES Fitted in Enclosures

- Prominent Ø 40mm (1.575) dia. red mushroom actuator, twist to release
- Robust polycarbonate enclosures
- Highly reliable positive break switching on E-stop
- Sealed to IP65
- 6A current rating
- Knockouts for popular conduit sizes
- Double pole changeover switch blocks available for momentary/maintained mushroom head pushbuttons

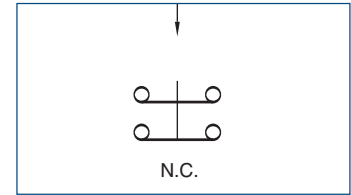

Emergency Stop

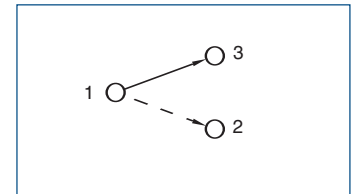

Momentary and Maintained

Technical Specifications

Contact Rating	: 6A 250 VAC/1.5A 250 VAC – E-Stop
Dimensions	: 65 x 65 x 57mm
Electrical Life	: 50,000 cycles/6050 cycles – E-Stop
Operating Temperature	: -20°C – +55°C

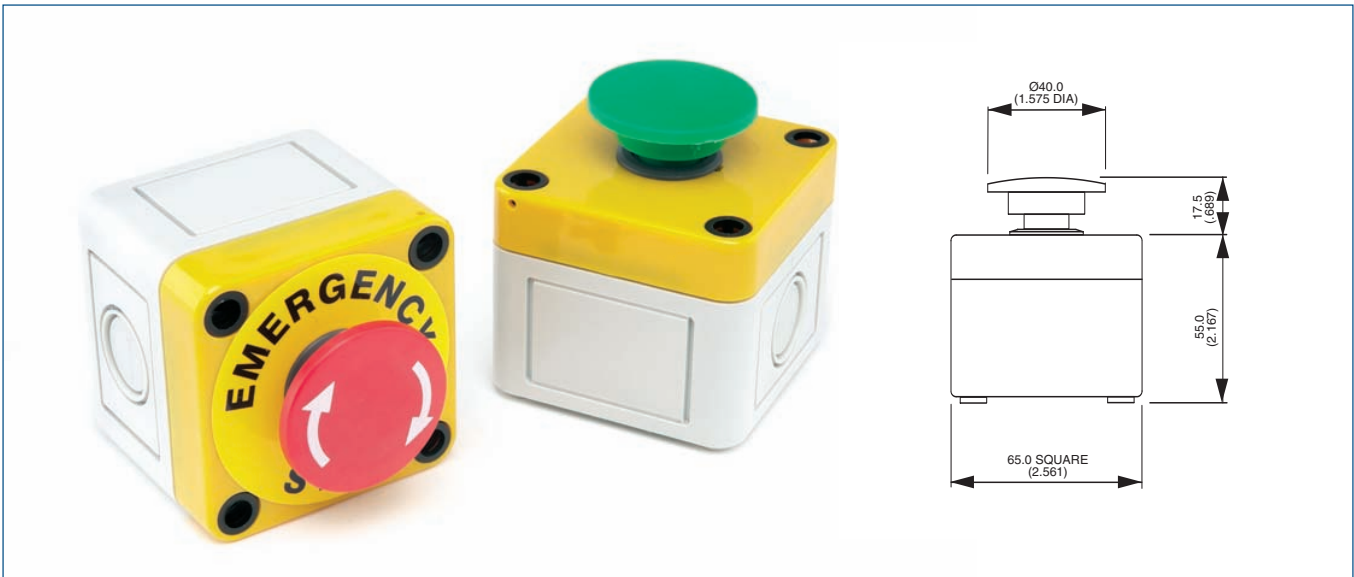

Description	Part No
Emergency Stop	A01ESSP354B + PEA01
Black Momentary	A01MMASP352B + PEA01
Red Momentary	A01MMBSP352B + PEA01
Yellow Momentary	A01MMDSP352B + PEA01
Green Momentary	A01MMESP352B + PEA01
Blue Momentary	A01MMFSP352B + PEA01
Black Maintained	A01MXASP352B + PEA01
Red Maintained	A01MXBSP352B + PEA01
Yellow Maintained	A01MXDSP352B + PEA01
Green Maintained	A01MXESP352B + PEA01
Blue Maintained	A01MXFSP352B + PEA01
Options	
12A 250V versions or custom printing on mushroom head actuators please contact APEM Components.	

A01 SERIES

MUSHROOM HEAD PUSHBUTTON SWITCHES

Panel cut-out Ø16 (.630)

- Prominent Ø 24mm (.944) or optional Ø 40mm (1.575) dia. mushroom actuators
- Momentary and maintained functions. Momentary function versions are unmarked, maintained function versions are twist release (arrows indicate direction of twist)
- Various coloured mushroom actuators are available

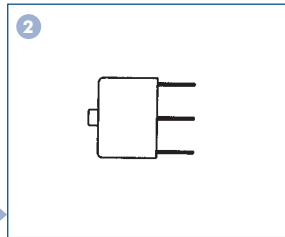
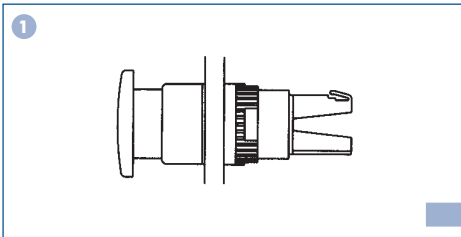
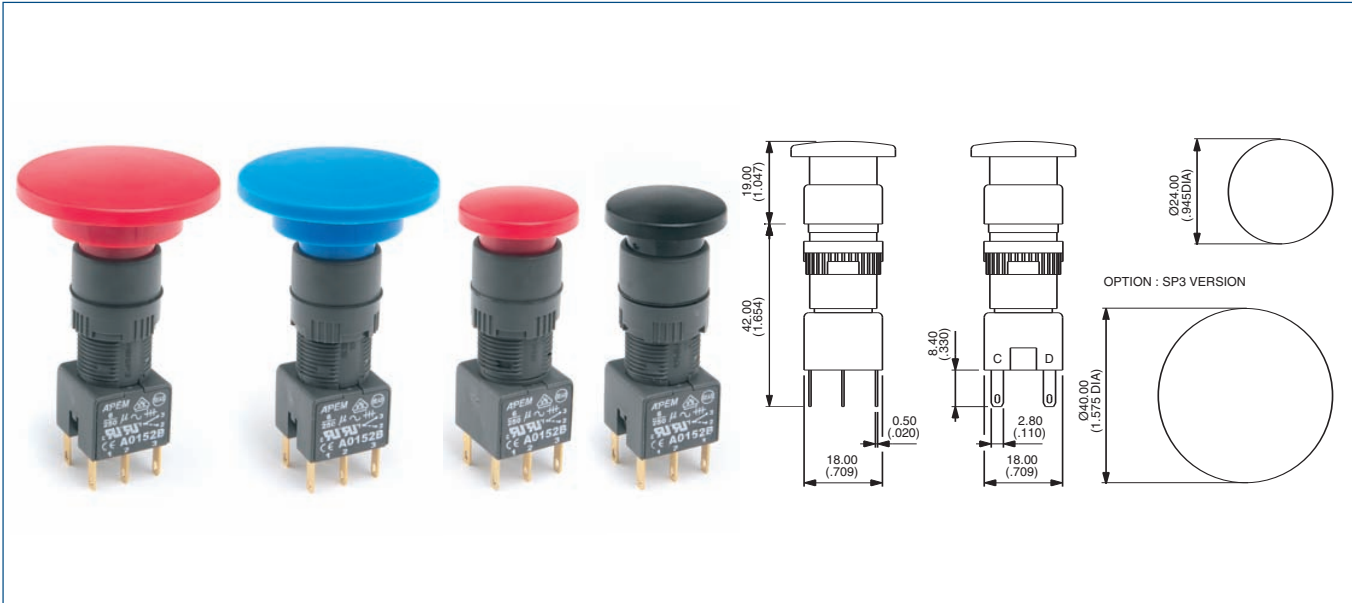
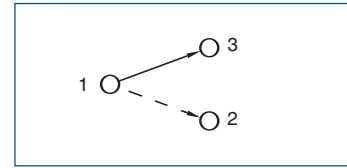

Operator

Actuator	Description	Part No
24mmØ	Black Momentary	A01MMA
24mmØ	Red Momentary	A01MMB
24mmØ	Yellow Momentary	A01MMD
24mmØ	Green Momentary	A01MME
24mmØ	Blue Momentary	A01MMF
24mmØ	Black Maintained	A01MXA
24mmØ	Red Maintained	A01MXB
24mmØ	Yellow Maintained	A01MXD
24mmØ	Green Maintained	A01MXE
24mmØ	Blue Maintained	A01MXF
40mmØ	Black Momentary	A01MMA SP3
40mmØ	Red Momentary	A01MMB SP3
40mmØ	Yellow Momentary	A01MMD SP3
40mmØ	Green Momentary	A01MME SP3
40mmØ	Blue Momentary	A01MMF SP3
40mmØ	Black Maintained	A01MXA SP3
40mmØ	Red Maintained	A01MXB SP3
40mmØ	Yellow Maintained	A01MXD SP3
40mmØ	Green Maintained	A01MXE SP3
40mmØ	Blue Maintained	A01MXF SP3

Switch block

No of poles	Part No
Single pole	A0151B
Double pole	A0152B
Three pole	A0155B
Four pole	A0153B

A01 SERIES

INDUSTRIAL CONTROLS

Accessories

FLUSH MOUNTING BEZELS Dark grey plastic material – supplied with sealing washer

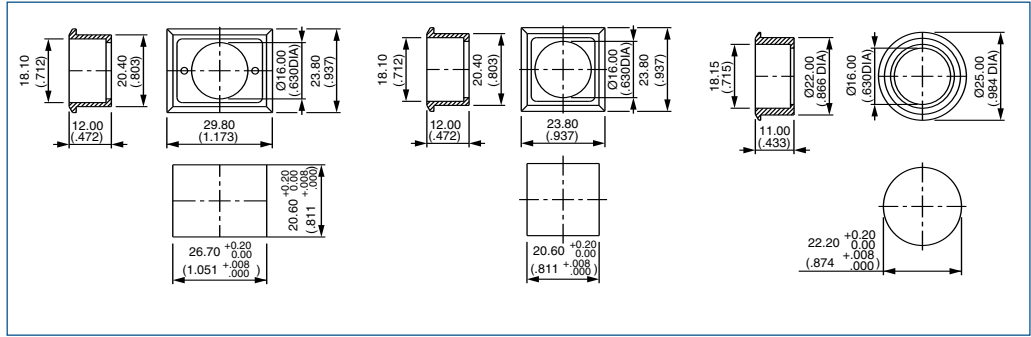

Rectangular **A01FM1**

Square **A01FM**

Round **A01FM2 ***

FLUSH MOUNTING BEZELS Anodised aluminium/matt black

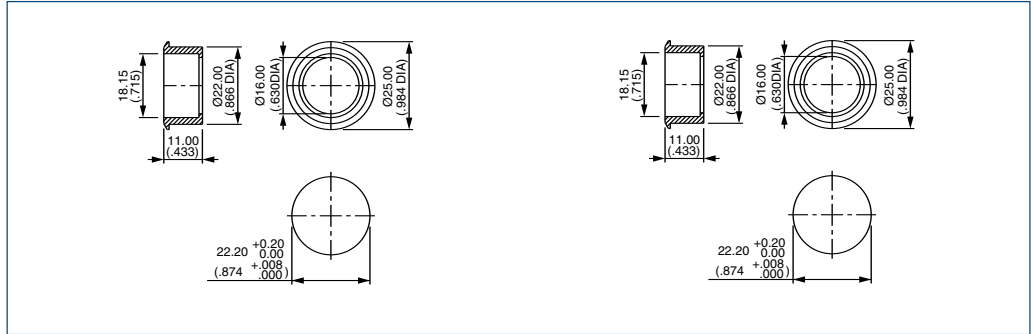

Round **A01FMM**

Round **A01FMMG**

PCB SOCKET

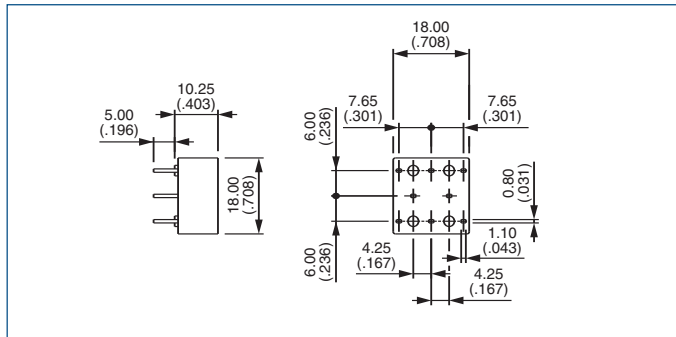

No of poles	Part No
Single pole, non illuminated	A01PC1
Double pole, non illuminated	A01PC2
Single pole, illuminated	A01PC3
Double pole, illuminated	A01PC4
Indicator	A01PC5
Single pole, E-stop	A01PC6
Double pole, E-stop	A01PC7

FLAPGUARDS

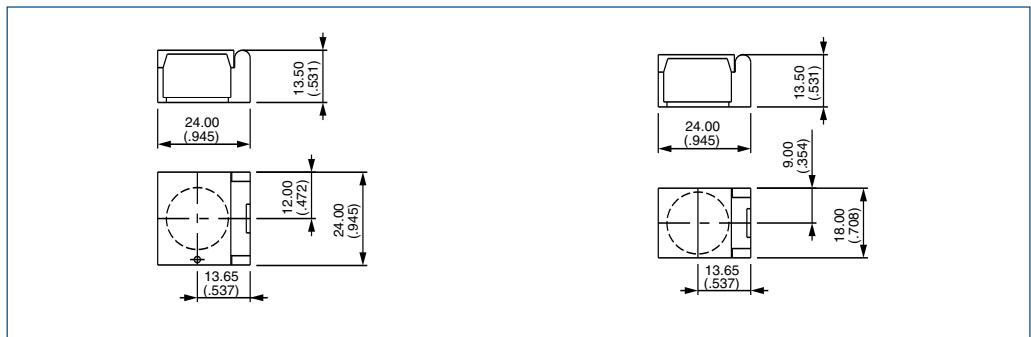

Rectangular **A01FG1**

Square/round **A01FG2**

A01 SERIES

Accessories

METAL GUARDS

→ Slot as alternative to Ø2mm hole. Material : 1 mm thick aluminium.

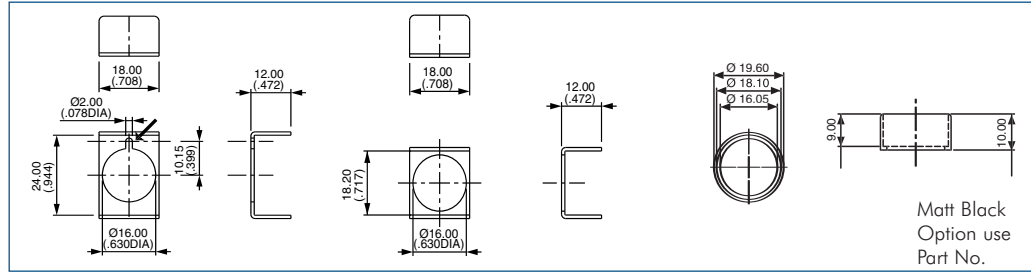

Rectangular **A01MG1**

Square **A01MG**

Round **A01MG2**

A01MG2G

Matt Black
Option use
Part No.

ANTI ROTATION RING

Recommended to prevent product rotation

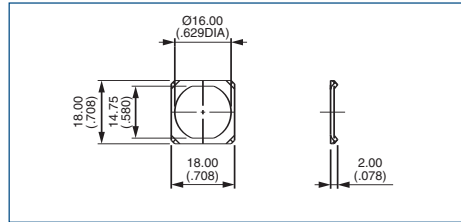

A01LW

ALUMINIUM SCREENS

For non-illuminated pushbuttons

For illuminated pushbuttons

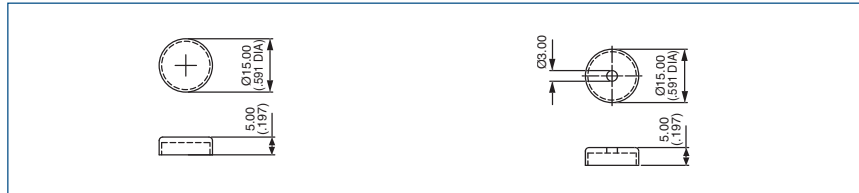
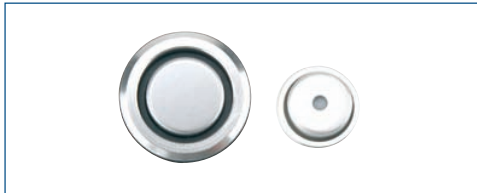

A0163AL

A0163AL1

SWITCHBLOCK TERMINAL GUARDS

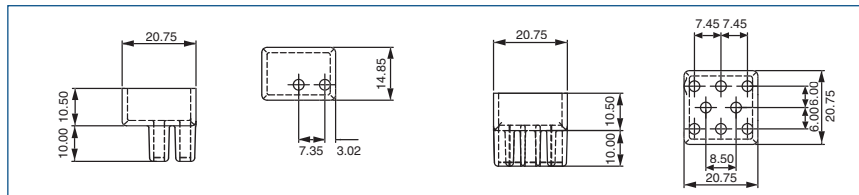

2 way **A01RTC2**

8 way **A01RTC8**

BLANKING PLUGS

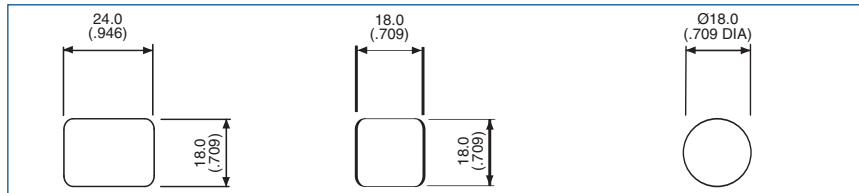

Rectangular **A0131**

Square **A0132**

Round **A0133**

RESISTOR ASSEMBLY

Resistor assembly – 2 stage illumination



A0152B + RISSP



(DIM) normally closed

(BRIGHT) normally open

A01 SERIES

INDUSTRIAL CONTROLS

Installation – tools

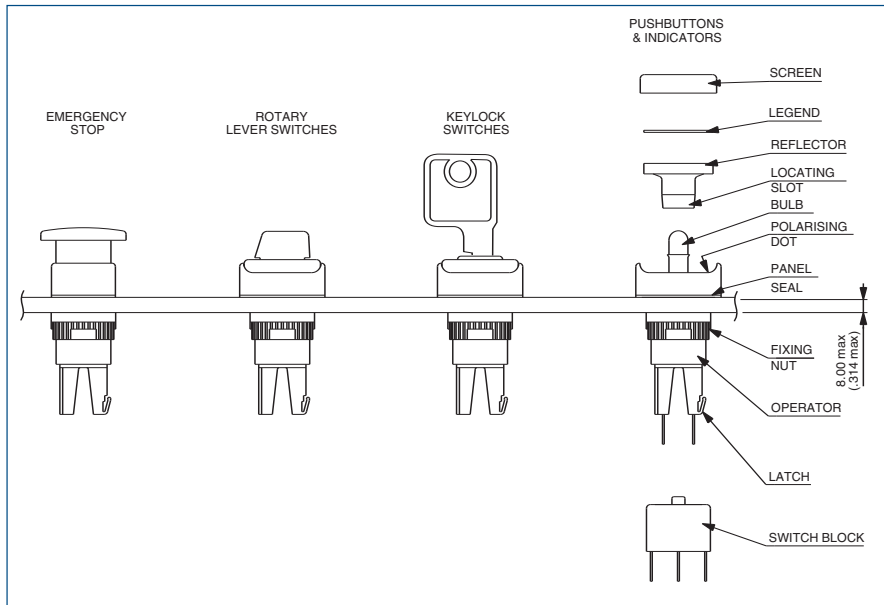

PANEL CUT-OUT

Round & square operators only

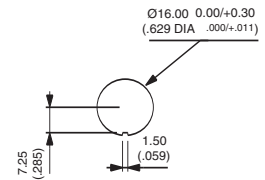

Rectangular operators only

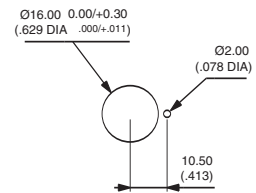

Max. panel thickness : 8mm (.314)

PANEL MOUNTING ASSEMBLY

- Drill/punch hole shaped as above.
- Assemble front operator through hole, fit fixing nut and tighten to a maximum torque of 0.8Nm using tool No. 30-0001.
- Wire chosen switch block as required and slide onto operator until latch engages.
- Fit bulb if required using tool No. 30-0002.
- Snap screen onto reflector assembly with legend in between if required and snap onto front operator TAKING CARE TO LINE UP THE LOCATING SLOT WITH THE POLARISING DOT, and not to damage the seal.

TO REMOVE BULB

Remove reflector/screen assembly. Use the bulb extractor 30-0002 to remove the bulb.

SWITCH BLOCK

To assemble switch block to front operator, firstly, TAKE CARE TO LINE UP SWITCH BLOCK WITH FRONT OPERATOR. Once in position slide on to front operator. N.B. Ensure latch is fully engaged correctly onto the switch block.

To remove switch block, depress the latch and slide the switch block off the operator.

FIXING NUT KEY



BULB REMOVER



A02 SERIES

ILLUMINATED OR NON-ILLUMINATED PUSHBUTTON SWITCHES

Panel cut-out Ø22 or 29.5 x 21.5

A pushbutton assembly requires:

screen + lamp (if illuminated) + operator + one or two switchblocks

To order these elements, select desired model numbers from tables below.

Example: IP65 rectangular maintained pushbutton, switch blocks with 2 N.O. contacts, red screen and 12V red LED assembly = A0261B, A0242J1, A0201X and A02503.

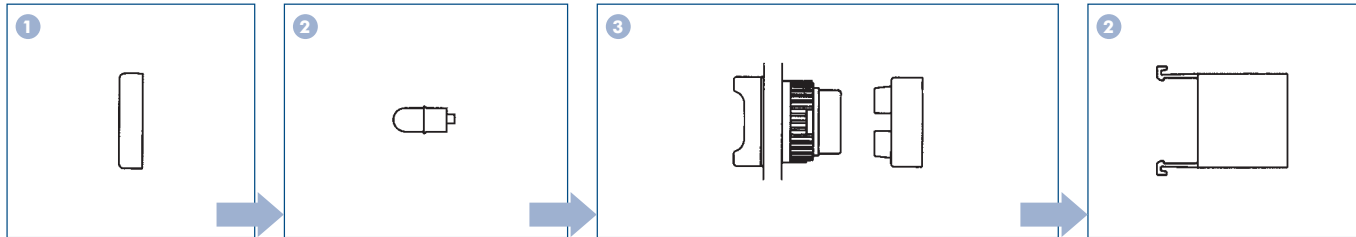
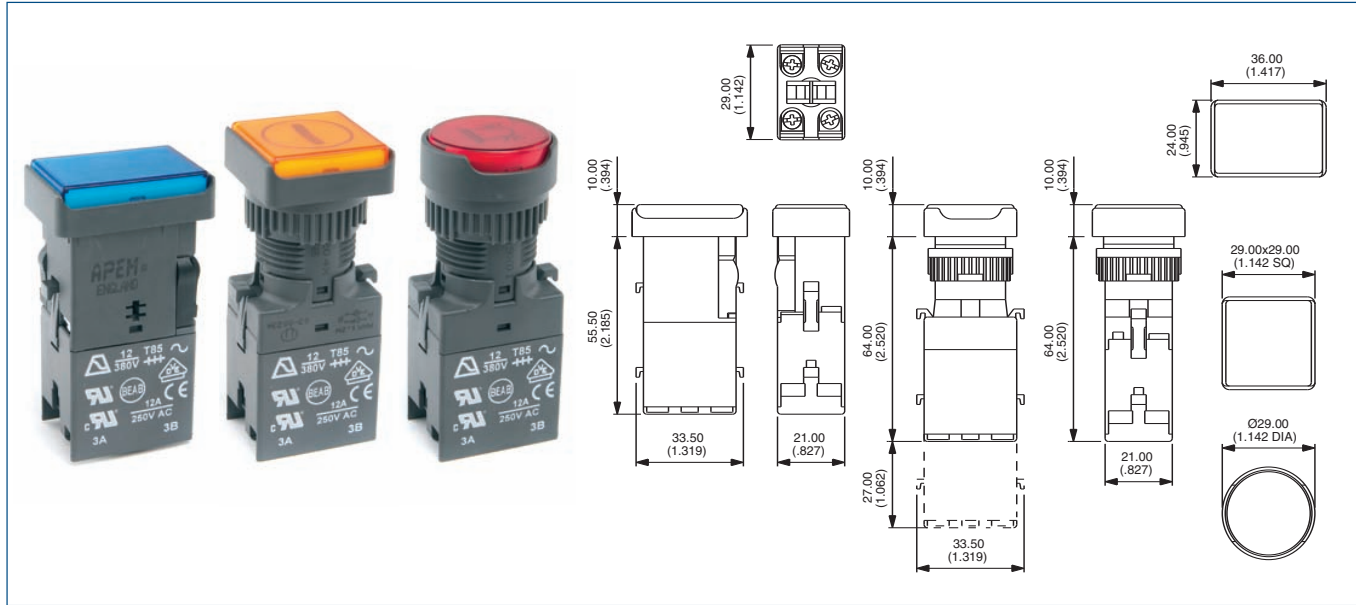
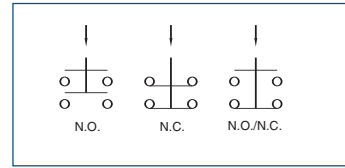

Screen

Bezel	Colour	Part No
<input type="checkbox"/>	black	A0261A
<input type="checkbox"/>	red	A0261B
<input type="checkbox"/>	amber	A0261C
<input type="checkbox"/>	yellow	A0261D
<input type="checkbox"/>	green	A0261E
<input type="checkbox"/>	blue	A0261F
<input type="checkbox"/>	clear	A0261G
<input type="checkbox"/>	white	A0261J
<input type="checkbox"/>	black	A0262A
<input type="checkbox"/>	red	A0262B
<input type="checkbox"/>	amber	A0262C
<input type="checkbox"/>	yellow	A0262D
<input type="checkbox"/>	green	A0262E
<input type="checkbox"/>	blue	A0262F
<input type="checkbox"/>	clear	A0262G
<input type="checkbox"/>	white	A0262J
<input type="checkbox"/>	black	A0263A
<input type="checkbox"/>	red	A0263B
<input type="checkbox"/>	amber	A0263C
<input type="checkbox"/>	yellow	A0263D
<input type="checkbox"/>	green	A0263E
<input type="checkbox"/>	blue	A0263F
<input type="checkbox"/>	clear	A0263G
<input type="checkbox"/>	white	A0263J

Lamp

Lamp	Voltage	Part No
Filament	6.3V	A0141A
Filament	14V	A0141B
Filament	28V	A0141C
Filament	36V	A0141D
Filament	48V	A0141E
Filament	60V	A0141F
Neon	110V	A0143G
Neon	220V	A0143H
LED lamp	model numbers	see Pages 6&7
Special LED Assemblies		
LED assy	6V	A0242H*
LED assy	12V	A0242J*
LED assy	24V	A0242K*
LED assy	6V	A0243H*
LED assy	12V	A0243J*
LED assy	24V	A0243K*
LED assy	6V	A0244H*
LED assy	12V	A0244J*
LED assy	24V	A0244K*
NB Replace * with colour code		
for LED assemblies:		
	1:	red
	2:	green
	3:	amber

Operator

Bezel	Description	Lamp type	Part No
<input type="checkbox"/>	Illum, momentary	Lamp/LED bulb	A0201Y
<input type="checkbox"/>	Illum, maintained	Lamp/LED bulb	A0201X
<input type="checkbox"/>	Illum, momentary	Special LED assy	A0202Y
<input type="checkbox"/>	Illum, maintained	Special LED assy	A0202X
<input type="checkbox"/>	Non-illum, momentary		A0203Y
<input type="checkbox"/>	Non-illum, maintained		A0203X
<input type="checkbox"/>	Illum, momentary	Lamp/LED bulb	A0204Y
<input type="checkbox"/>	Illum, maintained	Lamp/LED bulb	A0204X
<input type="checkbox"/>	Illum, momentary	Special LED assy	A0205Y
<input type="checkbox"/>	Illum, maintained	Special LED assy	A0205X
<input type="checkbox"/>	Non-illum, momentary		A0206Y
<input type="checkbox"/>	Non-illum, maintained		A0206X
<input type="checkbox"/>	Illum, momentary	Lamp/LED bulb	A0207Y
<input type="checkbox"/>	Illum, maintained	Lamp/LED bulb	A0207X
<input type="checkbox"/>	Illum, momentary	Special LED assy	A0208Y
<input type="checkbox"/>	Illum, maintained	Special LED assy	A0208X
<input type="checkbox"/>	Non-illum, momentary		A0209Y
<input type="checkbox"/>	Non-illum, maintained		A0209X

Switch block

Contacts	Part No
1 N.O.	A02501
1 N.C.	A02502
2 N.O.	A02503
2 N.C.	A02504
1 N.O./1 N.C.	A02505
Second switch block	
Contacts	
Part No	
1 N.O.	A02506
1 N.C.	A02507
2 N.O.	A02508
2 N.C.	A02509
1 N.O./1 N.C.	A02510

White or Blue LED Assembly:
contact APEM Components

Screen engraving/insertable legends:
contact APEM Components

To achieve 3 or 4 pole switching, add second switch block from above table.

Unsealed switches (IP40):
add '01' to end of operator model number

Bezel: rectangular square round. 'Illum' - illuminated,

'Non-illum' - non illuminated

A02 SERIES

METAL BEZEL PUSHBUTTON SWITCHES AND INDICATORS

Panel cut-out Ø22

A pushbutton assembly requires:

screen + lamp (if illuminated) + operator + one or two switchblocks

An indicator assembly requires : screen + lamp + operator

Example: IP65 metal bezel maintained pushbutton, switch block with 2 N.O. contacts, red screen and 12V red LED assembly = A0263B, A0244J1, A0211X and A02503

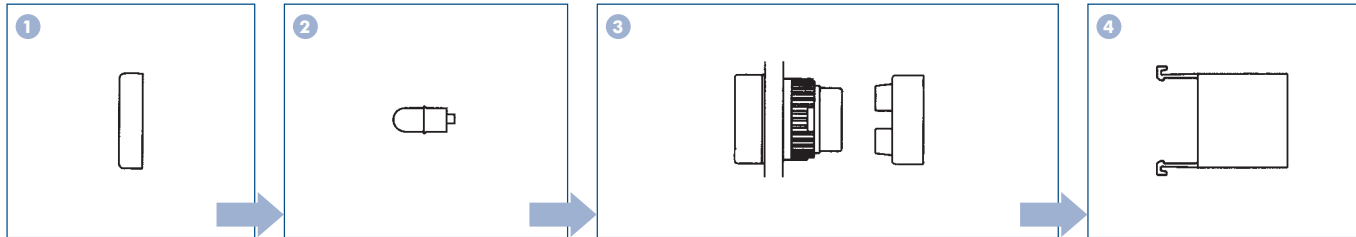
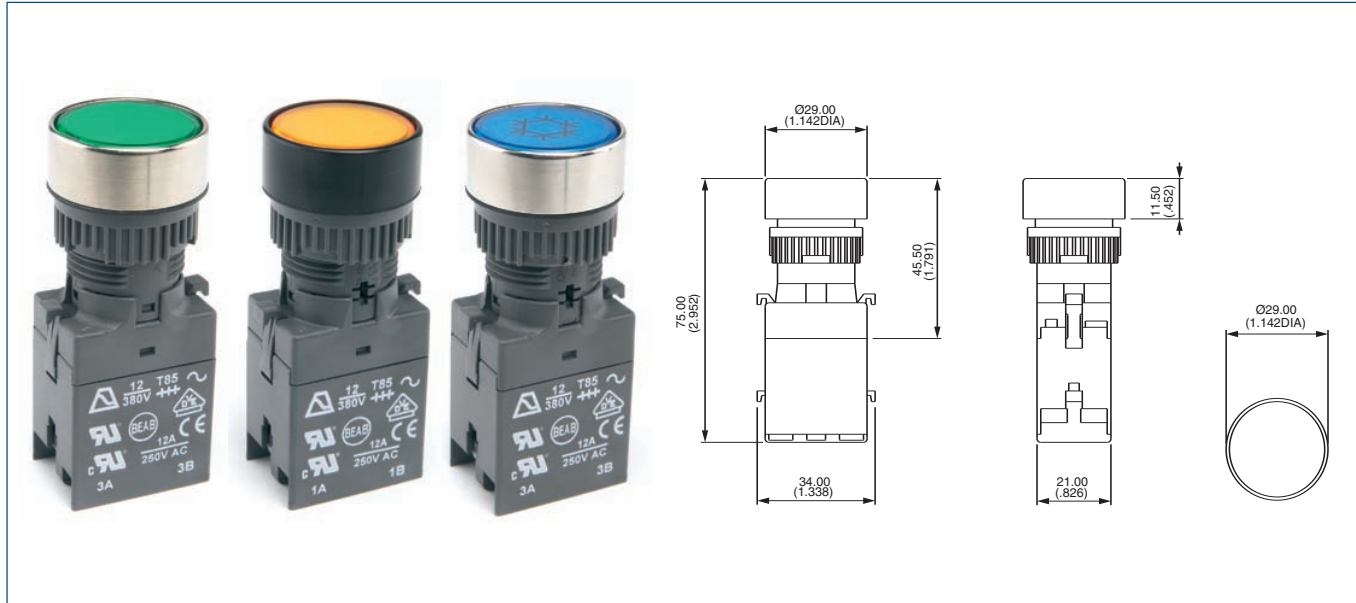
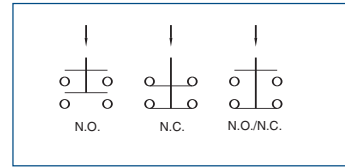

Screen

Bezel	Colour	Part No
○	black	A0263A
○	red	A0263B
○	amber	A0263C
○	yellow	A0263D
○	green	A0263E
○	blue	A0263F
○	clear	A0263G
○	white	A0263J

Lamp

Lamp	Voltage	Part No
Filament	6.3V	A0141A
Filament	14V	A0141B
Filament	28V	A0141C
Filament	36V	A0141D
Filament	48V	A0141E
Filament	60V	A0141F
Neon	110V	A0143G
Neon	220V	A0143H
LED lamp model numbers see Pages 6&7		
Special LED Assemblies		
LED assy ○	6V	A0244H*
LED assy ○	12V	A0244J*
LED assy ○	24V	A0244K*
NB Replace * with colour code for LED assemblies:		
	1: red	
	2: green	
	3: amber	

White or Blue LED Assembly:
contact APEM Components

Operator

Bezel	Description	Lamp type	Part No
○	Illum, momentary	Lamp/LED bulb	A0210Y
○	Illum, maintained	Lamp/LED bulb	A0210X
○	Illum, momentary	Special LED assy	A0211Y
○	Illum, maintained	Special LED assy	A0211X
○	Non-illum, momentary		A0212Y
○	Non-illum, maintained		A0212X
○	Illum, indicator	Lamp/LED bulb	A0277
○	Illum, indicator	Special LED assy	A0278

Std bezel material : nickel plated brass
For optional black finish, add 'G' to the end of operator model number.

Unsealed switches (IP40):
add '01' to end of operator model number

Screen engraving/insertable legends:
contact APEM Components

Switch block

Contacts	Part No
1 N.O.	A02501
1 N.C.	A02502
2 N.O.	A02503
2 N.C.	A02504
1 N.O./1 N.C.	A02505

Second switch block

Contacts	Part No
1 N.O.	A02506
1 N.C.	A02507
2 N.O.	A02508
2 N.C.	A02509
1 N.O./1 N.C.	A02510

To achieve 3 or 4 pole switching, add second switch block from above table.

Bezel: ○ round. 'Illum' - illuminated, 'Non-illum' - non illuminated

A02 SERIES

FLUSH MOUNTING PUSHBUTTON SWITCHES AND INDICATORS

Panel cut-out Ø30

A pushbutton assembly requires:

screen + lamp (if illuminated) + operator + one or two switchblocks

An indicator assembly requires : screen + lamp + operator

Example: IP65 flush mounting maintained pushbutton, switch block with 2 N.O. contacts, red screen and 12V red LED assembly
= A0263B, A0244J1, A0213X and A02503

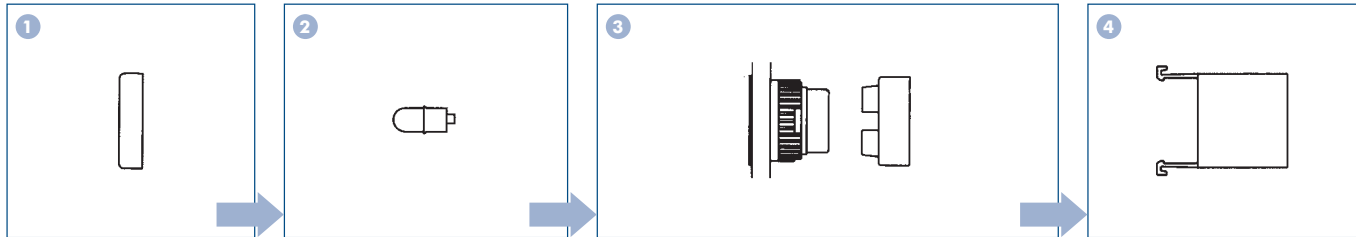
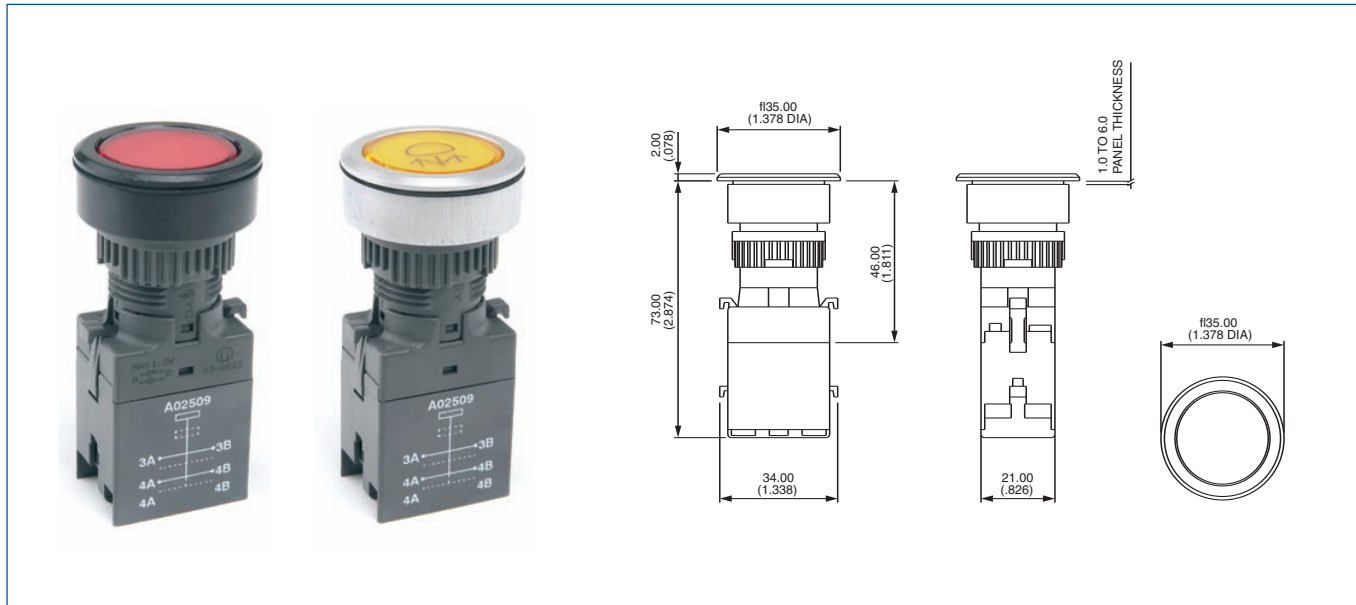
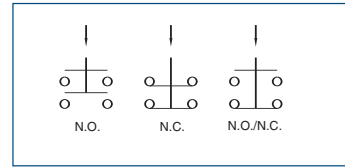

Screen

Bezel	Colour	Part No
○	black	A0263A
○	red	A0263B
○	amber	A0263C
○	yellow	A0263D
○	green	A0263E
○	blue	A0263F
○	clear	A0263G
○	white	A0263J

Lamp

Lamp	Voltage	Part No
Filament	6.3V	A0141A
Filament	14V	A0141B
Filament	28V	A0141C
Filament	36V	A0141D
Filament	48V	A0141E
Filament	60V	A0141F
Neon	110V	A0143G
Neon	220V	A0143H
LED lamp model numbers see Pages 6&7		
Special LED Assemblies		
LED assy	6V	A0244H*
LED assy	12V	A0244J*
LED assy	24V	A0244K*
NB Replace * with colour code for LED assemblies:		
	1: red	
	2: green	
	3: amber	

White or Blue LED Assembly:
contact APEM Components

Operator

Bezel	Description	Lamp type	Part No
○	Illum, momentary	Lamp/LED bulb	A0214Y
○	Illum, maintained	Lamp/LED bulb	A0214X
○	Illum, momentary	Special LED assy	A0213Y
○	Illum, maintained	Special LED assy	A0213X
○	Non-illum, momentary		A0215Y
○	Non-illum, maintained		A0215X
○	Illum, indicator	Lamp/LED bulb	A02791
○	Illum, indicator	Special LED assy	A02792

Std bezel material : silver anodised aluminium.
For optional black anodised aluminium, add 'G' to the end of **operator** model number.

Unsealed switches (IP40):
add '01' to end of **operator** model number

Screen engraving/insertable legends:
contact APEM Components

Switch block

Contacts	Part No
1 N.O.	A02501
1 N.C.	A02502
2 N.O.	A02503
2 N.C.	A02504
1 N.O./1 N.C.	A02505

Second switch block

Contacts	Part No
1 N.O.	A02506
1 N.C.	A02507
2 N.O.	A02508
2 N.C.	A02509
1 N.O./1 N.C.	A02510

To achieve 3 or 4 pole switching, add second switch block from above table.

Bezel: □ rectangular □ square ○ round. 'Illum' - illuminated, 'Non-illum' - non illuminated

A02 SERIES INDICATORS

Panel cut-out Ø22 or 29.5 x 21.5

An indicator assembly requires:

screen + lamp, LED bulb or LED assembly + operator

To order these elements, select desired model numbers from tables below.

Example: rectangular indicator with red screen and 12V red LED assembly
= A0261B, A0242J1 and A0272

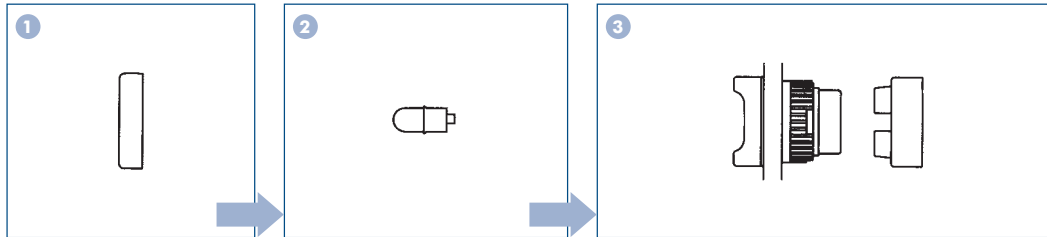
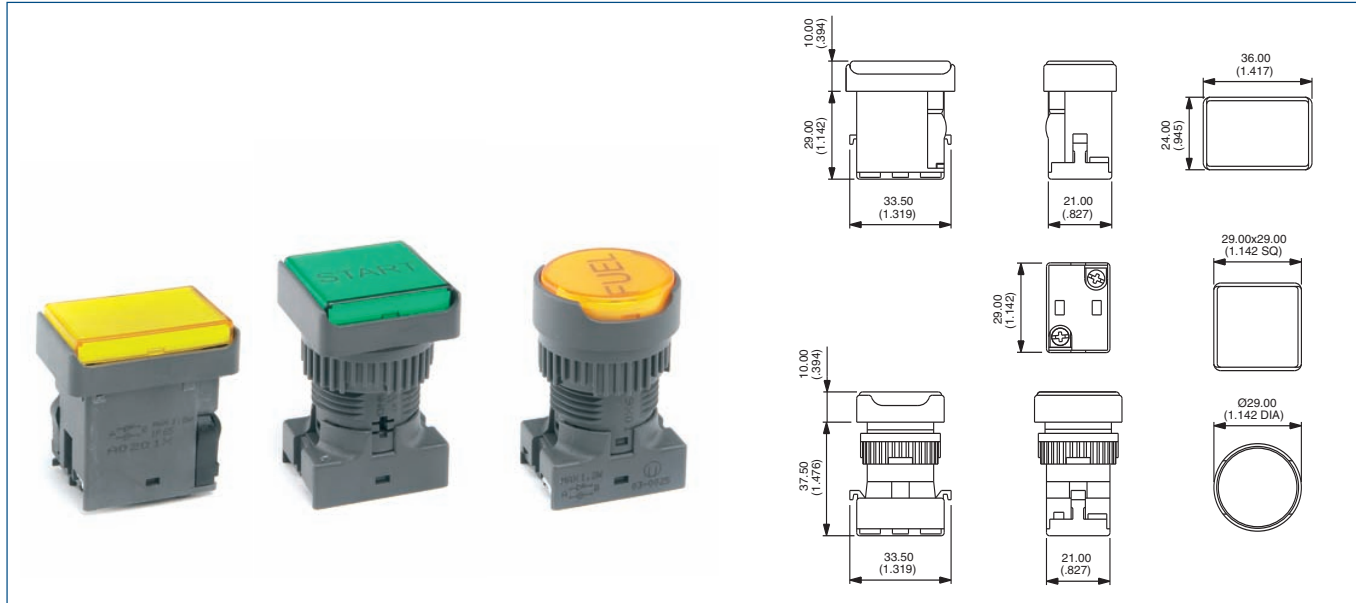

Screen

Bezel	Colour	Part No
<input type="checkbox"/>	black	A0261A
<input type="checkbox"/>	red	A0261B
<input type="checkbox"/>	amber	A0261C
<input type="checkbox"/>	yellow	A0261D
<input type="checkbox"/>	green	A0261E
<input type="checkbox"/>	blue	A0261F
<input type="checkbox"/>	clear	A0261G
<input type="checkbox"/>	white	A0261J
<input type="checkbox"/>	black	A0262A
<input type="checkbox"/>	red	A0262B
<input type="checkbox"/>	amber	A0262C
<input type="checkbox"/>	yellow	A0262D
<input type="checkbox"/>	green	A0262E
<input type="checkbox"/>	blue	A0262F
<input type="checkbox"/>	clear	A0262G
<input type="checkbox"/>	white	A0262J
<input type="checkbox"/>	black	A0263A
<input type="checkbox"/>	red	A0263B
<input type="checkbox"/>	amber	A0263C
<input type="checkbox"/>	yellow	A0263D
<input type="checkbox"/>	green	A0263E
<input type="checkbox"/>	blue	A0263F
<input type="checkbox"/>	clear	A0263G
<input type="checkbox"/>	white	A0263J

Lamp

Lamp	Voltage	Part No
Filament	6.3V	A0141A
Filament	14V	A0141B
Filament	28V	A0141C
Filament	36V	A0141D
Filament	48V	A0141E
Filament	60V	A0141F
Neon	110V	A0143G
Neon	220V	A0143H
LED lamp	model numbers	see Pages 6&7
Special LED Assemblies		
LED assy	<input type="checkbox"/> 6V	A0242H*
LED assy	<input type="checkbox"/> 12V	A0242J*
LED assy	<input type="checkbox"/> 24V	A0242K*
LED assy	<input type="checkbox"/> 6V	A0243H*
LED assy	<input type="checkbox"/> 12V	A0243J*
LED assy	<input type="checkbox"/> 24V	A0243K*
LED assy	<input type="checkbox"/> 6V	A0244H*
LED assy	<input type="checkbox"/> 12V	A0244J*
LED assy	<input type="checkbox"/> 24V	A0244K*
NB Replace * with colour code		
for LED assemblies: 1: red		
2: green		
3: amber		

Operator

Bezel	Description	Lamp type	Part No
<input type="checkbox"/>	Indicator	Lamp/LED bulb	A0271
<input type="checkbox"/>	Indicator	Special LED assy	A0272
<input type="checkbox"/>	Indicator	Lamp/LED bulb	A0273
<input type="checkbox"/>	Indicator	Special LED assy	A0274
<input type="checkbox"/>	Indicator	Lamp/LED bulb	A0275
<input type="checkbox"/>	Indicator	Special LED assy	A0276

White or Blue LED Assembly:

contact APEM Components

Screen engraving/insertable legends:

contact APEM Components

Unsealed indicators (IP40):

add '01' to end of operator model number

Bezel: rectangular square round

A02 SERIES

ROTARY SWITCHES

Panel cut-out Ø22 (.866)

A rotary lever assembly requires:

operator + one or two switchblocks

To order these elements, select desired model numbers from tables below.

Example: IP65 square 2 position maintained rotary switch with long lever, switch block with 2 N.O. contacts = A029101 and A02503.

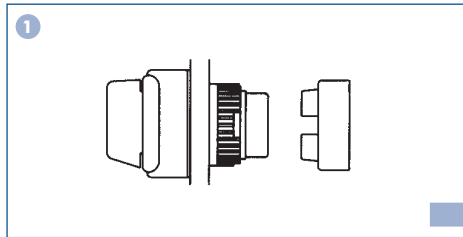
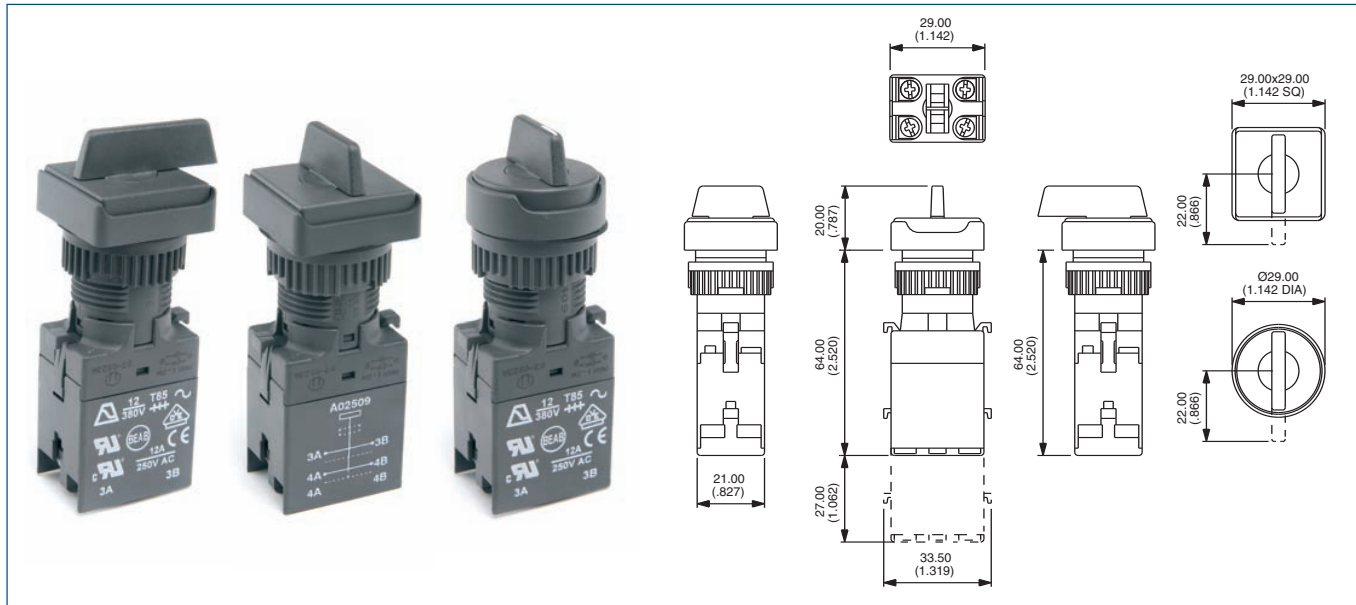
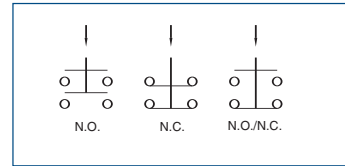

Operator

Bezel	Description	Short lever	Long lever
<input type="checkbox"/>	2 pos. maintained	A029201	A029101
<input type="checkbox"/>	2 pos. momentary	A029202	A029102
<input type="checkbox"/>	3 pos. maintained	A029203	A029103
<input type="checkbox"/>	3 pos. momentary	A029204	A029104
<input type="checkbox"/>	3 pos. mainL, momR	A029205	A029105
<input type="checkbox"/>	3 pos. momL, mainR	A029206	A029106
<input checked="" type="checkbox"/>	2 pos. maintained	A029401	A029301
<input checked="" type="checkbox"/>	2 pos. momentary	A029402	A029302
<input checked="" type="checkbox"/>	3 pos. maintained	A029403	A029303
<input checked="" type="checkbox"/>	3 pos. momentary	A029404	A029304
<input checked="" type="checkbox"/>	3 pos. mainL, momR	A029405	A029305
<input checked="" type="checkbox"/>	3 pos. momL, mainR	A029406	A029306

To specify flush mounting (30mmØ) option: add 'FM' to the end of the part number:
Example: A029401FM (round operators only)

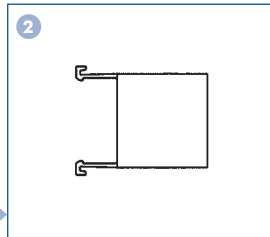

Switch block

Contacts	Part No
1 N.O.	A02501
1 N.C.	A02502
2 N.O.	A02503
2 N.C.	A02504
1 N.O./1 N.C.	A02505

Second switch block

Contacts	Part No
1 N.O.	A02506
1 N.C.	A02507
2 N.O.	A02508
2 N.C.	A02509
1 N.O./1 N.C.	A02510

To achieve 3 or 4 pole switching, add second switch block from above table.

Lever Positions

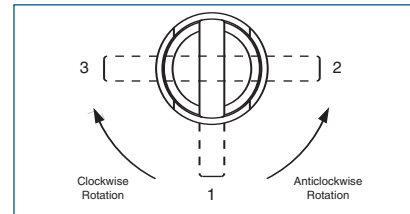

• Lever Rotation – 2 position switches

The model numbers shown are for switches with anticlockwise lever rotation.

For clockwise rotation, replace:

01 with **07**
02 with **08**

at the end of the model number

Optional Engraving on Lever End



To order add 'WL' to the end of the part number.

Example: A029401WL

Bezel: square round

A02 SERIES

KEYLOCK SWITCHES

Panel cut-out Ø22 or 29.5 x 21.5

A keylock assembly requires:

operator + one or two switchblocks

To order these elements, select desired model numbers from tables below.

Example: IP65 square 2 position maintained keyswitch, switch block with 2 N.O. contacts = A028201 and A02503

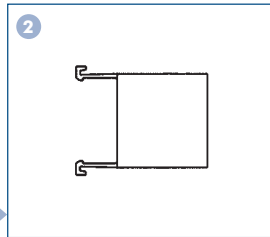
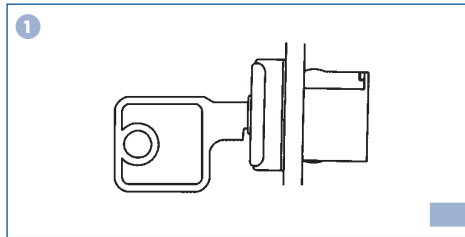
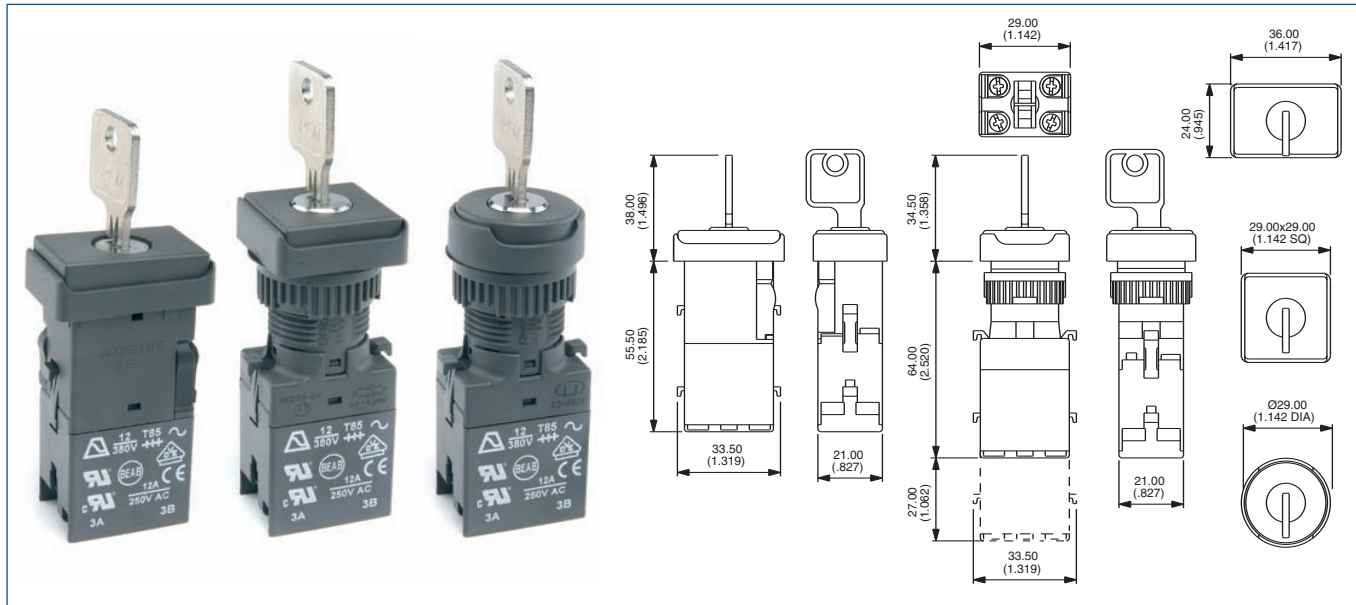
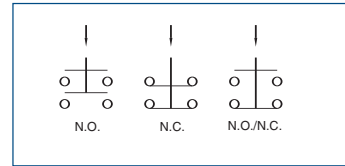

Key Positions

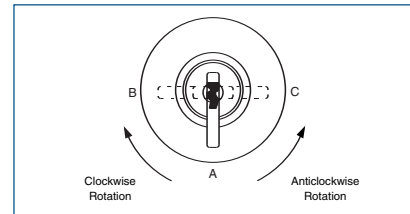

Operator

Bezel	Description	Part No.	Key removable in positions
	2 pos. maintained	A028101	A-C
	2 pos. momentary	A028102	A
	3 pos. maintained	A028105	A-B-C
	3 pos. momentary	A028106	A
	3 pos. mainL, momR	A028107	A-B
	3 pos. momL, mainR	A028108	A-C
	2 pos. maintained	A028201	A-C
	2 pos. momentary	A028202	A
	3 pos. maintained	A028205	A-B-C
	3 pos. momentary	A028206	A
	3 pos. mainL, momR	A028207	A-B
	3 pos. momL, mainR	A028208	A-C
	2 pos. maintained	A028301	A-C
	2 pos. momentary	A028302	A
	3 pos. maintained	A028305	A-B-C
	3 pos. momentary	A028306	A
	3 pos. mainL, momR	A028307	A-B
	3 pos. momL, mainR	A028308	A-C

Switch block

Contacts	Part No
1 N.O.	A02501
1 N.C.	A02502
2 N.O.	A02503
2 N.C.	A02504
1 N.O./1 N.C.	A02505

Second switch block

Contacts	Part No
1 N.O.	A02506
1 N.C.	A02507
2 N.O.	A02508
2 N.C.	A02509
1 N.O./1 N.C.	A02510

To specify flush mounting (30mmØ) option: add 'FM' to the end of the part number:
Example: A028301FM (round operator only)

To achieve 3 or 4 pole switching, add second switch block from above table.

Key Rotation – 2 position switches

The model numbers shown are for switches with anticlockwise lever rotation.

For clockwise rotation, replace:

01 with 20
 02 with 19

at the end of the model number

- 2 standard keys are supplied
- 20 key barrel types available from stock
- Non-removable key positions: contact APEM components

Bezel: rectangular square round. 'pos' - position, 'mainL' - maintained left 'momR' - momentary right, etc

A02 SERIES

EMERGENCY STOP SWITCHES

Panel cut-out Ø22 (.866)

- Prominent 40mm (1.575) dia. red mushroom actuator
- Highly reliable positive break switch
- Push to shut off switch, twist to reset to ON

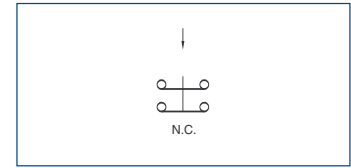

An emergency stop switch assembly requires:

operator + switch block

To order specify with single pole or double pole positive break switch block.

Approved to UL1054/EN 60947-5-5

General Specifications

Min Mechanical Life	: 6050 cycles (6 cycles per minute)
Operating Force	: 20N
Operating Temperature	: -20°C to +85°C
Degree of Environmental Protection (IEC 529)	: IP65 front of panel IP40 back of panel
Switch Terminals	: M3 screws-wire 2 x 0.75mm ² max

Electrical Specifications

Current/Voltage rating	: 2.5A 380VAC AC-15
Contact Gap	: >3mm
Dielectric test voltage	: 2500V
Electrical Life	: >6050

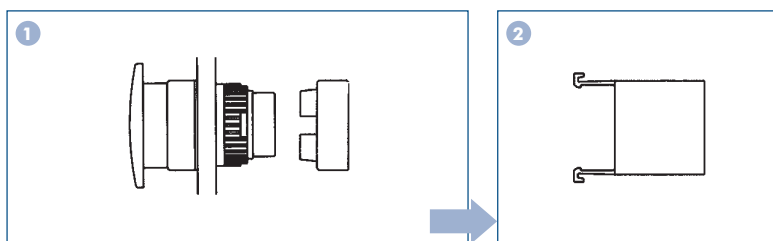
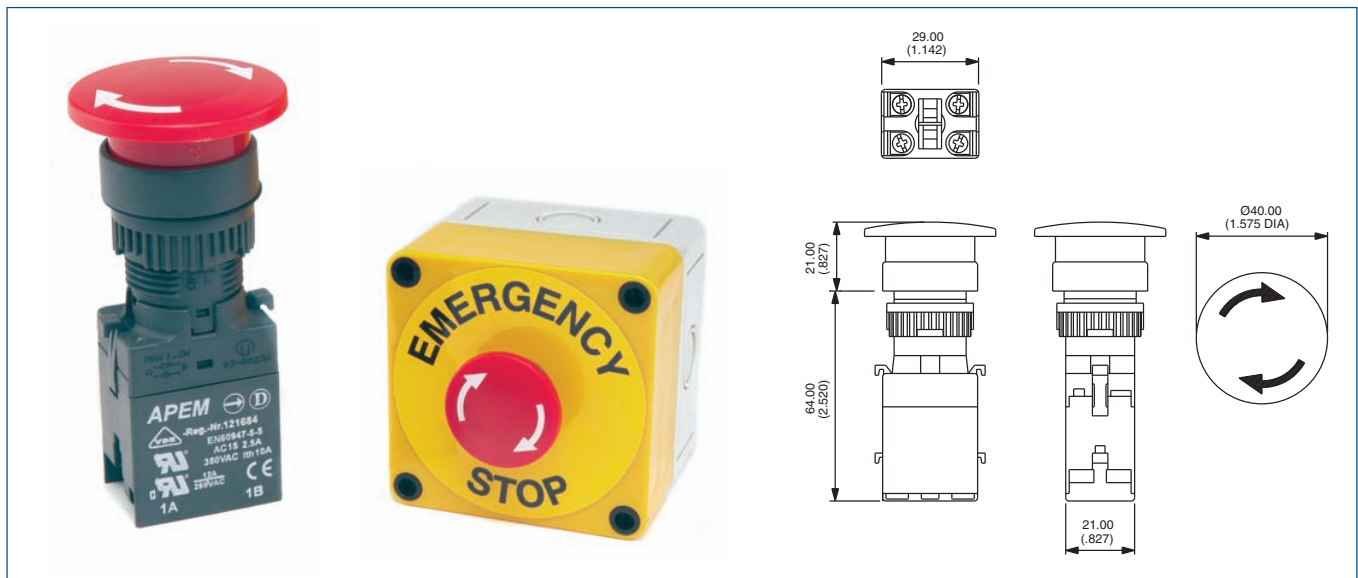

Operator

Bezel	Description	Part No
○	E-Stop operator	A02ES

Switch block

No of poles	Part No
Double pole	A02511
Single pole	A02512

Accessories



90Ø Self Adhesive Label

Description	Part No
Yellow label with text	A02YL1
Yellow label	A02YL2

To order the Emergency Stop Switch in the Plastic Enclosure with a 2 Pole Positive break Switchblock and Emergency Stop label use **part number: A02PE2L**

Bezel: ○ round.

A02 SERIES

MUSHROOM HEAD PUSHBUTTON SWITCHES

Panel cut-out Ø22 (.866)

- Prominent 40mm (1.575) dia. mushroom actuator
- Momentary and maintained functions, momentary function versions are unmarked, maintained function versions are twist to release (arrows indicate direction of twist)
- Various coloured mushroom actuators are available

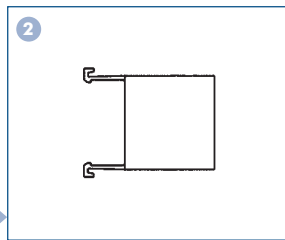
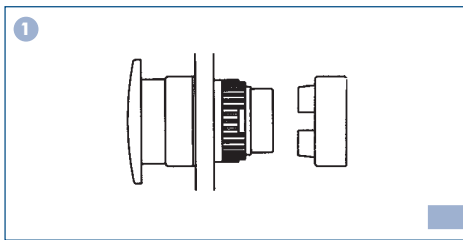
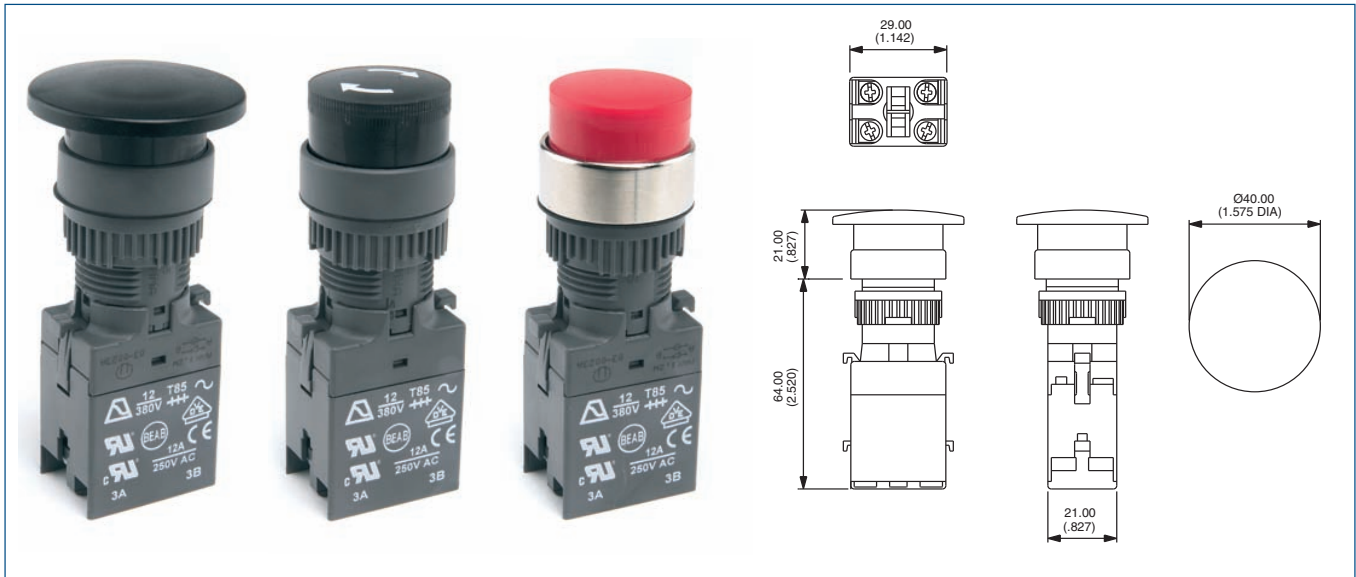
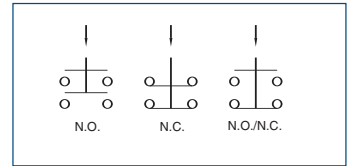

Operator

Bezel	Description	Part No
○	Black momentary	A02MMA
○	Red momentary	A02MMB
○	Yellow momentary	A02MMD
○	Green momentary	A02MME
○	Blue momentary	A02MMF
○	Black maintained	A02MXA
○	Red maintained	A02MXB
○	Yellow maintained	A02MXD
○	Green maintained	A02MXE
○	Blue maintained	A02MXF

Switch block

Contacts	Part No
1 N.O.	A02501
1 N.C.	A02502
2 N.O.	A02503
2 N.C.	A02504
1 N.O./1 N.C.	A02505

Second switch block

Contacts	Part No
1 N.O.	A02506
1 N.C.	A02507
2 N.O.	A02508
2 N.C.	A02509
1 N.O./1 N.C.	A02510

For optional reduced (Ø26mm) mushroom head operators: contact APEM Components

To achieve 3 or 4 pole switching, add second switch block from above table.

Bezel: ○ round.

A02 SERIES

INDUSTRIAL CONTROLS

Installation

Modular Construction/panel mounting

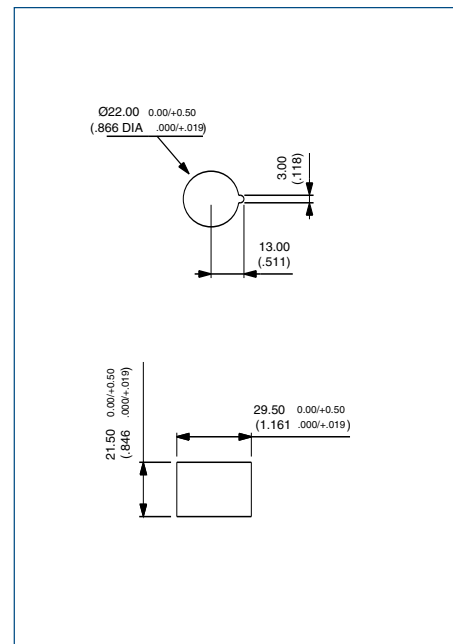
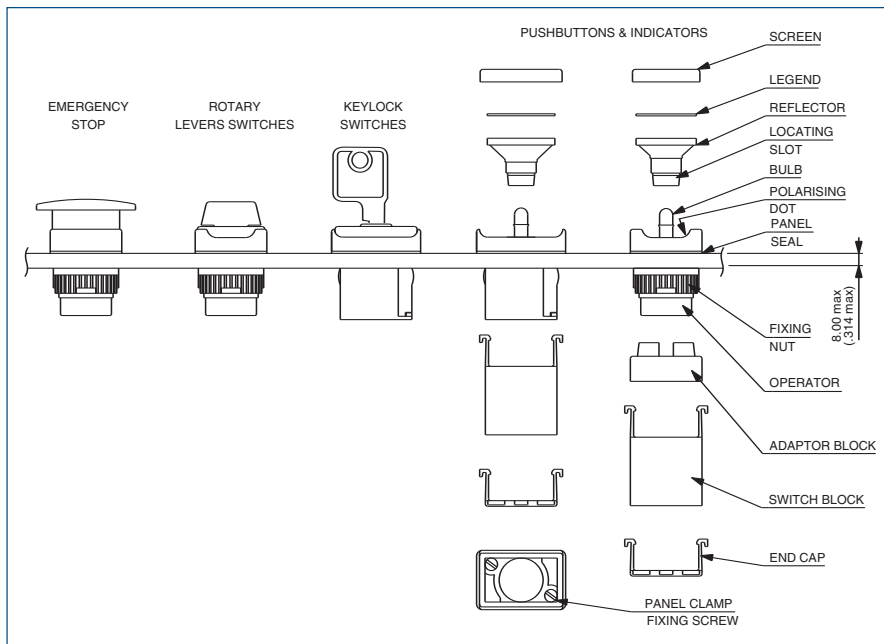

PANEL MOUNTING ASSEMBLY

- Drill/punch hole in panel as shaped above.
- Assemble front operator through hole and:
 - Round & Square types:* tighten nut to a maximum torque of 0,8Nm using tool No. 30-0001. Snap on adaptor block
 - Rectangular types:* tighten two panel fixing screws in front to a maximum torque of 6cNm.
- Wire chosen switch block as required and snap onto front operator.
- Snap end cap onto switch block (optional).
- Fit bulb if required using tool No. 30-0002.
- Snap screen onto reflector assembly with legend in between if required and snap onto front operator **TAKING CARE TO LINE UP THE LOCATING SLOT WITH THE POLARISING DOT**, and not to damage the seal.

TO REMOVE BULB

Remove reflector/screen assembly. Use the bulb extractor 30-0002 to remove the bulb.

TO REMOVE SWITCH BLOCK

Lever out latches using small screwdriver taking care not to overbend, and pull off the block from the front of operator.

A02 Accessories

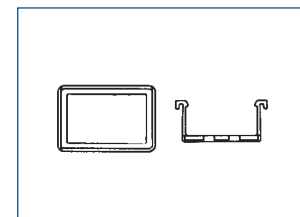

End cap terminal guard
offering unique terminal protection.
Part No. 14-0005

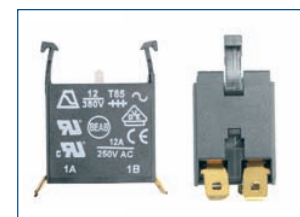

6.35mm Push on tab terminals
Specify 'SP' to the end of the switchblock
and operator part No.
Example: A02503SP

Dimensions: First dimensions are in mm while inches are shown in bracketed numbers.

Tolerance: The general tolerance for dimensions in this catalogue is +/- 0,3 (.012).

Dimensions, specifications and data shown in this catalogue are subject to change without notice.

A03 SERIES

ILLUMINATED OR NON-ILLUMINATED PUSHBUTTON SWITCHES & INDICATORS

Panel cut-out Ø22 OR Ø30mm Plastic or Metal Flush Mounting Bezel

A pushbutton assembly requires:

screen + lamp (if illuminated) + operator + switchblock

To order these elements, select desired model numbers from the table below.

Example: IP65 flush mounting round pushbutton, maintained function, red screen, single pole switch block and 12v red LED

= A0314X, A0263B, A0142M1 and A0151B

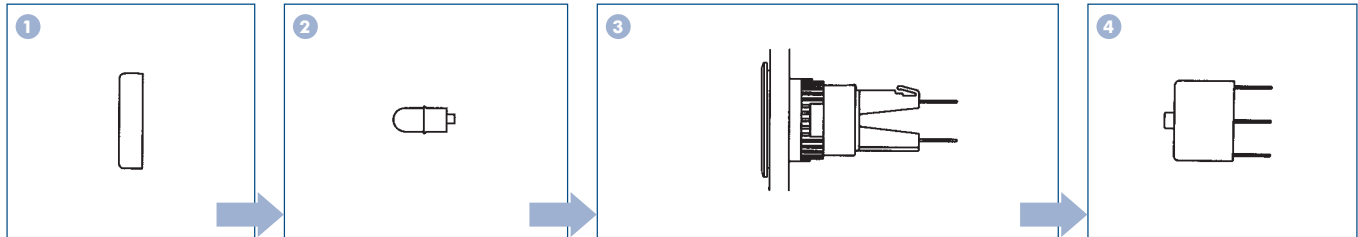
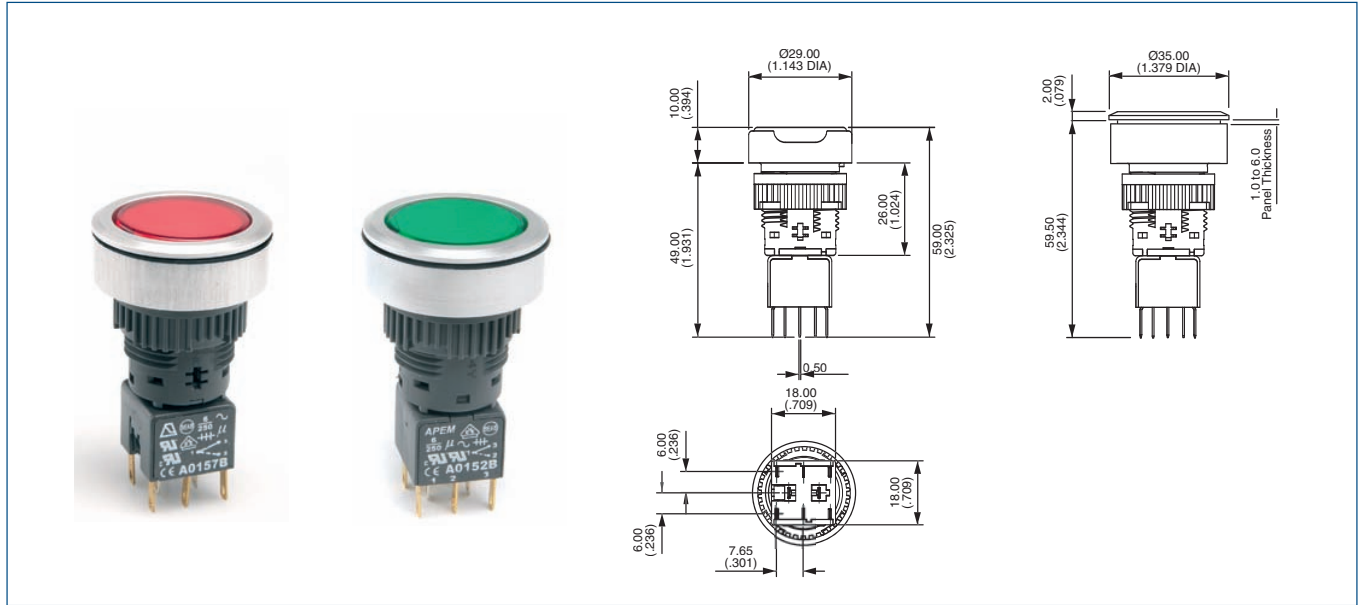
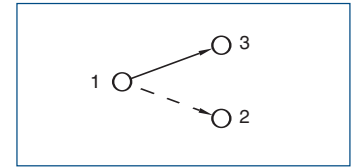

Screen

Bezel	Colour	Part No
○	black	A0263A
○	red	A0263B
○	amber	A0263C
○	yellow	A0263D
○	green	A0263E
○	blue	A0263F
○	clear	A0263G
○	white	A0263J

Lamp

Lamp	Voltage	Part No
Filament	6.3V	A0141A
Filament	14V	A0141B
Filament	28V	A0141C
Filament	36V	A0141D
Filament	48V	A0141E
Filament	60V	A0141F
Neon	110V	A0143G
Neon	220V	A0143H
LED	6V red	A0142L1
LED	6V green	A0142L2
LED	6V amber	A0142L3
LED	12V red	A0142M1
LED	12V green	A0142M2
LED	12V amber	A0142M3
LED	12V blue	A0142M4
LED	12V white	A0142M5
LED	24V red	A0142N1
LED	24V green	A0142N2
LED	24V amber	A0142N3
LED	24V blue	A0142N4
LED	24V white	A0142N5
LED	48V red	A0142P1
LED	48V green	A0142P2
LED	48V amber	A0142P3

Operator

Bezel	Description	Lamp type	Part No
○	Plastic illum, momentary	Lamp/LED bulb	A0307Y
○	Plastic illum, maintained	Lamp/LED bulb	A0307X
○	Plastic non-illum, momentary		A0309Y
○	Plastic non-illum, maintained		A0309X
○	Metal illum, momentary	Lamp/LED bulb	A0310Y
○	Metal illum, maintained	Lamp/LED bulb	A0310X
○	Metal non-illum, momentary		A0312Y
○	Metal non-illum, maintained		A0312X
○	F/mount illum, momentary	Lamp/LED bulb	A0314Y
○	F/mount illum, maintained	Lamp/LED bulb	A0314X
○	F/mount non-illum, momentary		A0315Y
○	F/mount non-illum, maintained		A0315X
○	Plastic indicator		A0375
○	Metal indicator		A0377
○	F/mount indicator		A03791

Switch block

No of poles	Part No
Single pole	A0151B
Double pole	A0152B
Three pole	A0155B
Four pole	A0153B

Unsealed switches (IP40):
add '01' to end of
operator model number

**Screen engraving/
insertable legends:**
contact **APEM** Components

Bezel: ○ round. 'illum' - illuminated, 'Non-illum' - non illuminated

N SERIES

PUSH-PULL SWITCHES

Panel cut-out Ø12

- Latching double pole changeover
- Ø24mm diameter operating button
- Selection of button colours
- Solder lug terminals

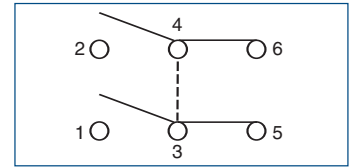

General Specifications

Panel cut-out	: 12mm dia.
Actuator diameter	: 24mm
Travel	: 2.3mm
Operating temperature	: -20°C – +70°C
Panel thickness	: 8mm max.
Switch terminals	: Solder lug

Electrical Specifications

Electrical function	: Double pole changeover
Maximum rating	: 2A, 250V AC
Contact resistance	: 10 milliOhms max
Electrical life	: 10,000 cycles at full load

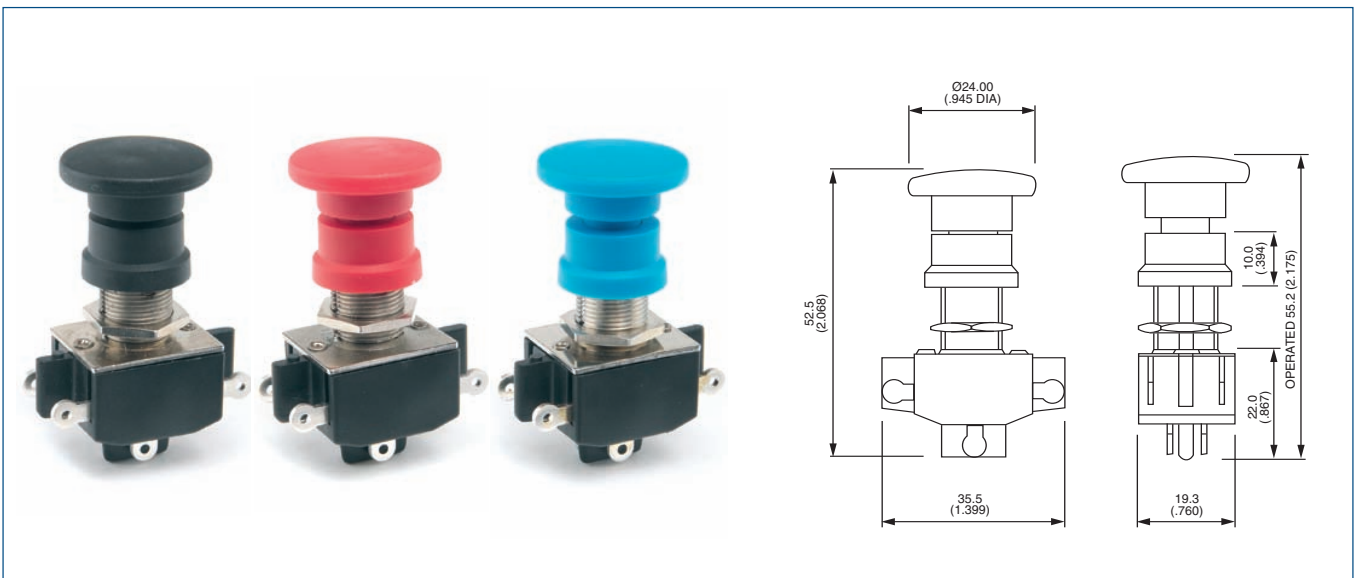

Description	Part No
Black plunger	N46A
Red plunger	N46B
Yellow plunger	N46D
Green plunger	N46E
Blue plunger	N46F

Options available

- 40mm head version
- Metal head version
- Custom printing on plunger please contact APEM components

APEM SPECIAL ASSEMBLIES



A01 Flush mounting assemblies

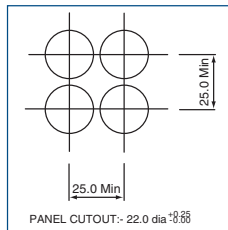

Round

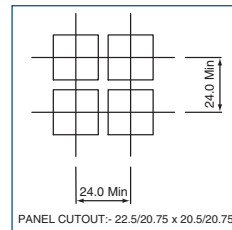

Square

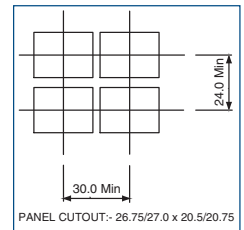

Rectangular

For single part number assemblies, i.e. switch supplied with bulb, screen, legend and flush mounting bezel (if required) fitted, please contact APEM Components.

- Rectangular - A1PR*****
- Square - A1PS*****
- Round - A1PC*****

* = To be confirmed by APEM Components

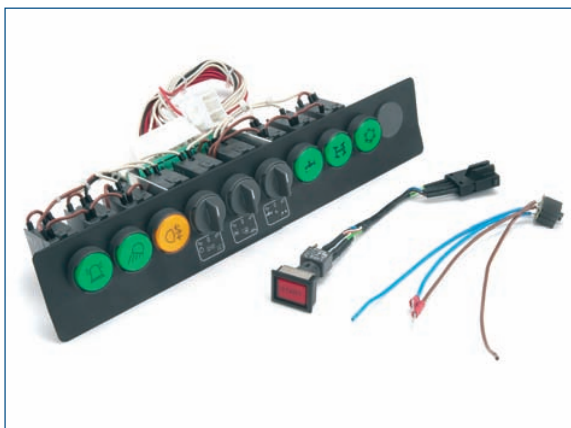
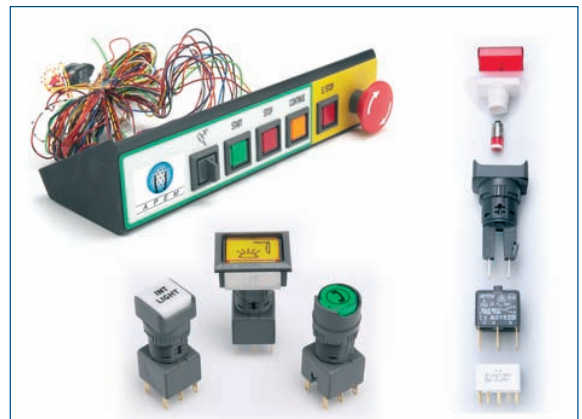

APEM components are able to offer fully integrated switch and cable assemblies.

Please contact APEM Components for further details.



A P E M

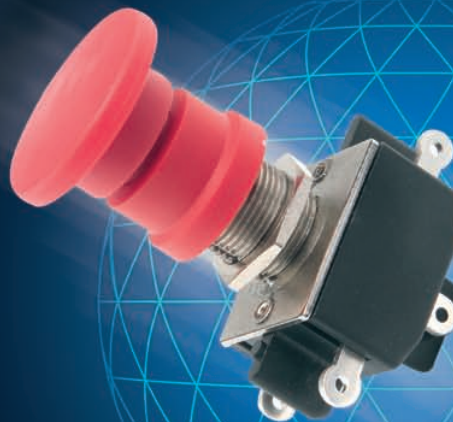

Apem Components Limited
Drakes Drive
Long Crendon
Bucks HP18 9BA
United Kingdom

Tel: (+44) 1844 202400
Fax: (+44) 1844 202500
Email: sales@apem.co.uk
Website: www.apem.co.uk