

A02 SERIES

ILLUMINATED OR NON-ILLUMINATED PUSHBUTTON SWITCHES

Panel cut-out Ø22 or 29.5 x 21.5

A pushbutton assembly requires:

screen + lamp (if illuminated) + operator + one or two switchblocks

To order these elements, select desired model numbers from tables below.

Example: IP65 rectangular maintained pushbutton, switch blocks with 2 N.O. contacts, red screen and 12V red LED assembly = A0261B, A0242J1, A0201X and A02503.

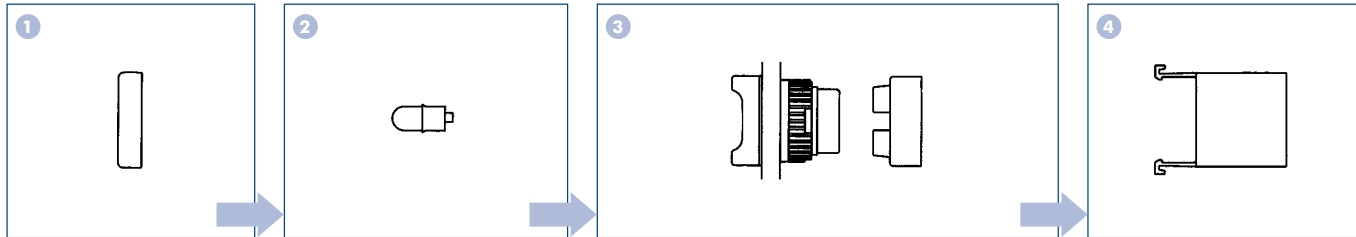
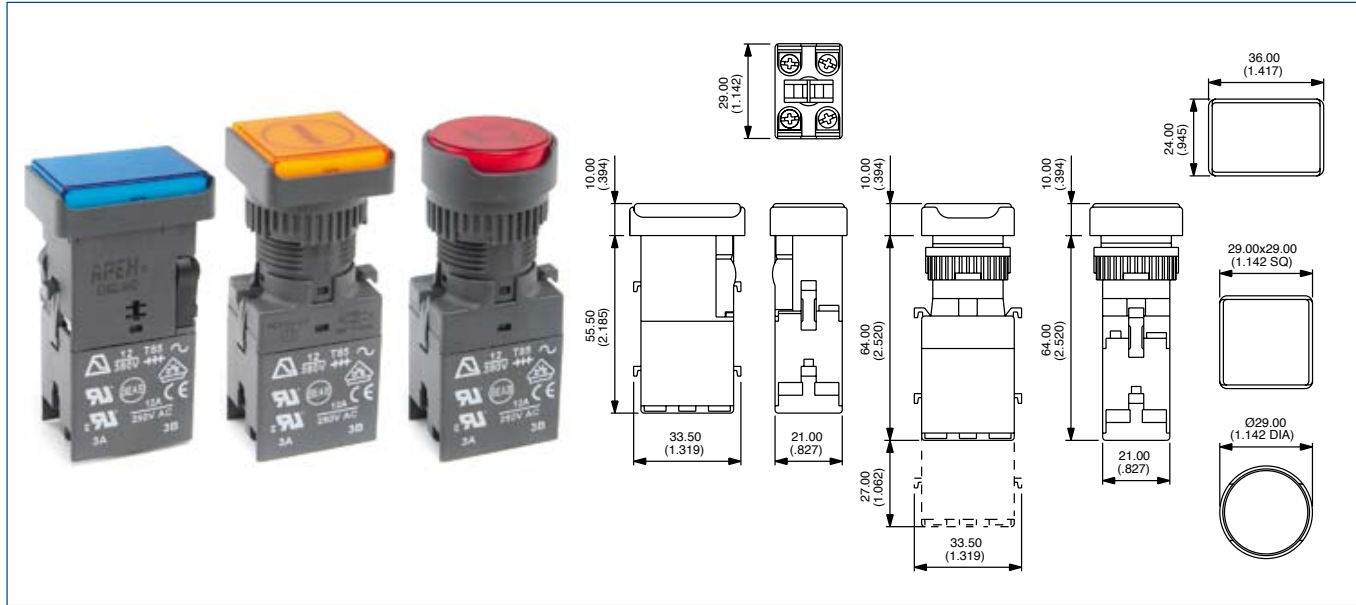
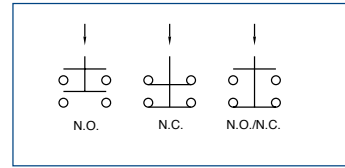

Screen

Bezel	Colour	Part No
□	black	A0261A
□	red	A0261B
□	amber	A0261C
□	yellow	A0261D
□	green	A0261E
□	blue	A0261F
□	clear	A0261G
□	white	A0261J
□	black	A0262A
□	red	A0262B
□	amber	A0262C
□	yellow	A0262D
□	green	A0262E
□	blue	A0262F
□	clear	A0262G
□	white	A0262J
○	black	A0263A
○	red	A0263B
○	amber	A0263C
○	yellow	A0263D
○	green	A0263E
○	blue	A0263F
○	clear	A0263G
○	white	A0263J

Lamp

Lamp	Voltage	Part No
Filament	6.3V	A0141A
Filament	14V	A0141B
Filament	28V	A0141C
Filament	36V	A0141D
Filament	48V	A0141E
Filament	60V	A0141F
Neon	110V	A0143G
Neon	220V	A0143H
LED lamp	model numbers	see Pages 6&7
Special LED Assemblies		
LED assy	□ 6V	A0242H*
LED assy	□ 12V	A0242J*
LED assy	□ 24V	A0242K*
LED assy	□ 6V	A0243H*
LED assy	□ 12V	A0243J*
LED assy	□ 24V	A0243K*
LED assy	○ 6V	A0244H*
LED assy	○ 12V	A0244J*
LED assy	○ 24V	A0244K*
NB Replace * with colour code		
for LED assemblies:		
	1:	red
	2:	green
	3:	amber

Operator

Bezel	Description	Lamp type	Part No
□	Illum, momentary	Lamp/LED bulb	A0201Y
□	Illum, maintained	Lamp/LED bulb	A0201X
□	Illum, momentary	Special LED assy	A0202Y
□	Illum, maintained	Special LED assy	A0202X
□	Non-illum, momentary		A0203Y
□	Non-illum, maintained		A0203X
□	Illum, momentary	Lamp/LED bulb	A0204Y
□	Illum, maintained	Lamp/LED bulb	A0204X
□	Illum, momentary	Special LED assy	A0205Y
□	Illum, maintained	Special LED assy	A0205X
□	Non-illum, momentary		A0206Y
□	Non-illum, maintained		A0206X
○	Illum, momentary	Lamp/LED bulb	A0207Y
○	Illum, maintained	Lamp/LED bulb	A0207X
○	Illum, momentary	Special LED assy	A0208Y
○	Illum, maintained	Special LED assy	A0208X
○	Non-illum, momentary		A0209Y
○	Non-illum, maintained		A0209X

Switch block

Contacts	Part No
1 N.O.	A02501
1 N.C.	A02502
2 N.O.	A02503
2 N.C.	A02504
1 N.O./1 N.C.	A02505

Second switch block

Contacts	Part No
1 N.O.	A02506
1 N.C.	A02507
2 N.O.	A02508
2 N.C.	A02509
1 N.O./1 N.C.	A02510

To achieve 3 or 4 pole switching, add second switch block from above table.

Unsealed switches (IP40): add '01' to end of operator model number

White or Blue LED Assembly: contact APEM Components

Screen engraving/insertable legends: contact APEM Components

Bezel: □ rectangular □ square ○ round. 'Illum' - illuminated, 'Non-illum' - non illuminated

A02 SERIES

METAL BEZEL PUSHBUTTON SWITCHES AND INDICATORS

Panel cut-out Ø22

A pushbutton assembly requires:

screen + lamp (if illuminated) + operator + one or two switchblocks

An indicator assembly requires : screen + lamp + operator

Example: IP65 metal bezel maintained pushbutton, switch block with 2 N.O. contacts, red screen and 12V red LED assembly = A0263B, A0244J1, A0211X and A02503

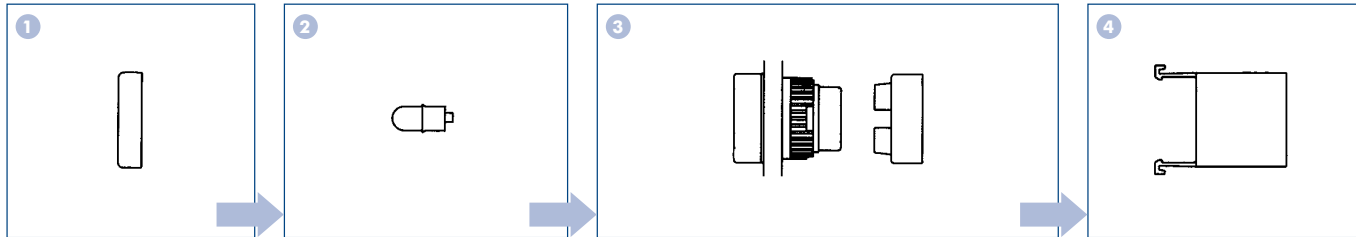
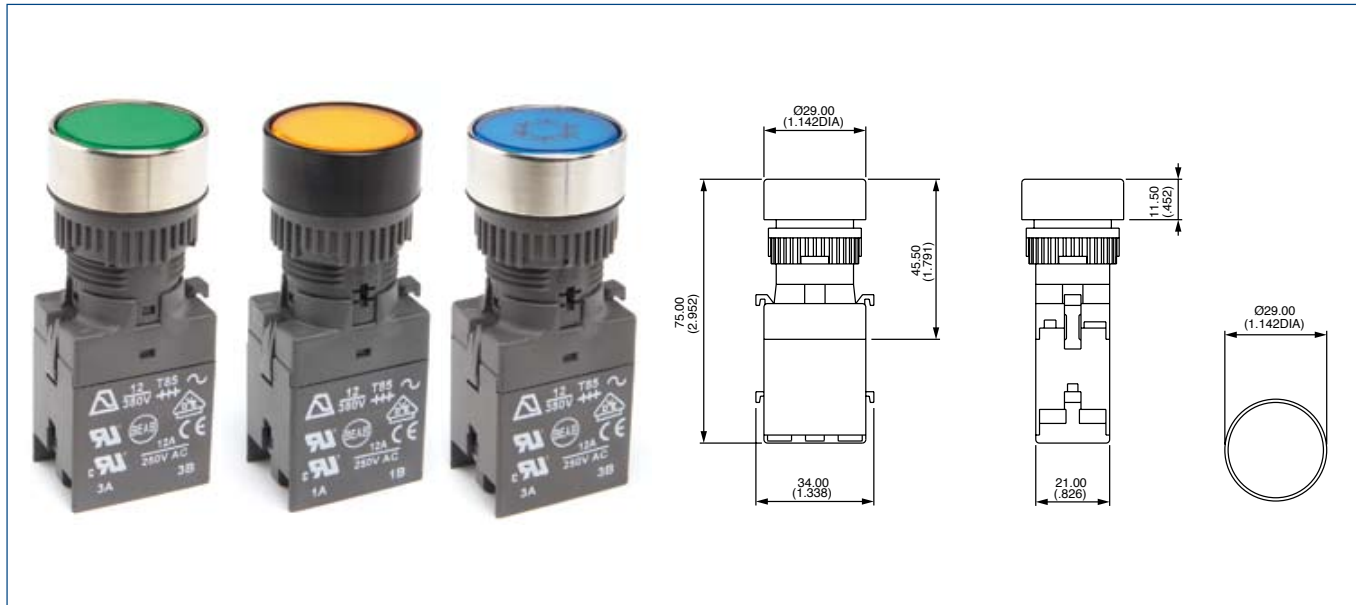
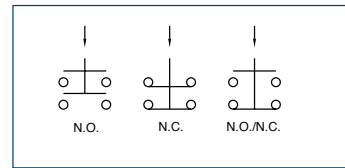

Screen

Bezel	Colour	Part No
○	black	A0263A
○	red	A0263B
○	amber	A0263C
○	yellow	A0263D
○	green	A0263E
○	blue	A0263F
○	clear	A0263G
○	white	A0263J

Lamp

Lamp	Voltage	Part No
Filament	6.3V	A0141A
Filament	14V	A0141B
Filament	28V	A0141C
Filament	36V	A0141D
Filament	48V	A0141E
Filament	60V	A0141F
Neon	110V	A0143G
Neon	220V	A0143H
LED lamp model numbers see Pages 6&7		
Special LED Assemblies		
LED assy ○	6V	A0244H*
LED assy ○	12V	A0244J*
LED assy ○	24V	A0244K*
NB Replace * with colour code for LED assemblies:		
	1: red	
	2: green	
	3: amber	

White or Blue LED Assembly:
contact APEM Components

Operator

Bezel	Description	Lamp type	Part No
○	Illum, momentary	Lamp/LED bulb	A0210Y
○	Illum, maintained	Lamp/LED bulb	A0210X
○	Illum, momentary	Special LED assy	A0211Y
○	Illum, maintained	Special LED assy	A0211X
○	Non-illum, momentary		A0212Y
○	Non-illum, maintained		A0212X
○	Illum, indicator	Lamp/LED bulb	A0277
○	Illum, indicator	Special LED assy	A0278

Std bezel material : nickel plated brass
For optional black finish, add 'G' to the end of operator model number.

Unsealed switches (IP40):
add '01' to end of operator model number

Screen engraving/insertable legends:
contact APEM Components

Switch block

Contacts	Part No
1 N.O.	A02501
1 N.C.	A02502
2 N.O.	A02503
2 N.C.	A02504
1 N.O./1 N.C.	A02505

Second switch block

Contacts	Part No
1 N.O.	A02506
1 N.C.	A02507
2 N.O.	A02508
2 N.C.	A02509
1 N.O./1 N.C.	A02510

To achieve 3 or 4 pole switching, add second switch block from above table.

Bezel: ○ round. 'Illum' - illuminated, 'Non-illum' - non illuminated

A02 SERIES

FLUSH MOUNTING PUSHBUTTON SWITCHES AND INDICATORS

Panel cut-out Ø30

A pushbutton assembly requires:

screen + lamp (if illuminated) + operator + one or two switchblocks

An indicator assembly requires : screen + lamp + operator

Example: IP65 flush mounting maintained pushbutton, switch block with 2 N.O. contacts, red screen and 12V red LED assembly
= A0263B, A0244J1, A0213X and A02503

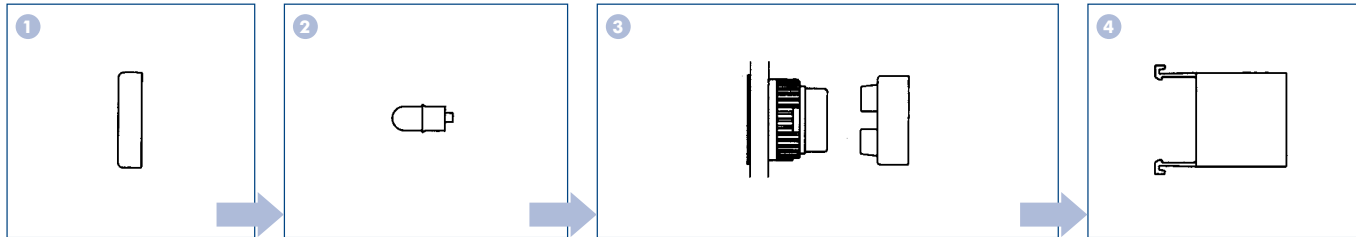
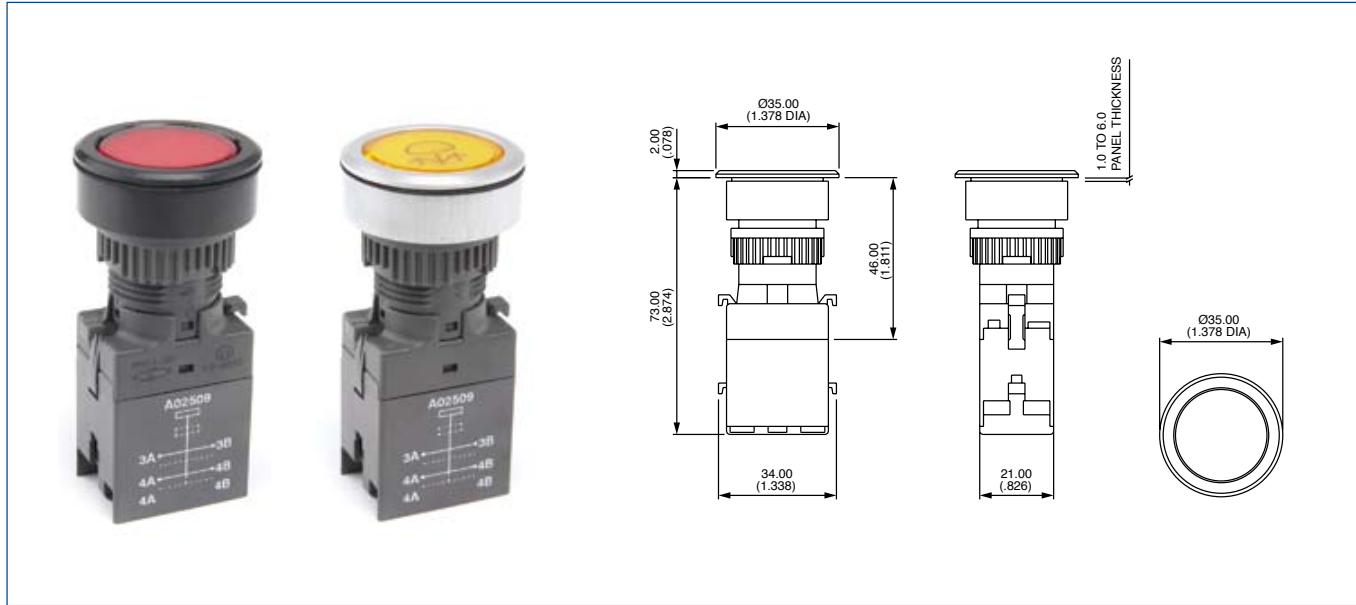
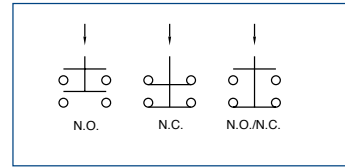

Screen

Bezel	Colour	Part No
○	black	A0263A
○	red	A0263B
○	amber	A0263C
○	yellow	A0263D
○	green	A0263E
○	blue	A0263F
○	clear	A0263G
○	white	A0263J

Lamp

Lamp	Voltage	Part No
Filament	6.3V	A0141A
Filament	14V	A0141B
Filament	28V	A0141C
Filament	36V	A0141D
Filament	48V	A0141E
Filament	60V	A0141F
Neon	110V	A0143G
Neon	220V	A0143H
LED lamp model numbers see Pages 6&7		
Special LED Assemblies		
LED assy	6V	A0244H*
LED assy	12V	A0244J*
LED assy	24V	A0244K*
NB Replace * with colour code for LED assemblies:		
	1: red	
	2: green	
	3: amber	

White or Blue LED Assembly:
contact APEM Components

Operator

Bezel	Description	Lamp type	Part No
○	Illum, momentary	Lamp/LED bulb	A0214Y
○	Illum, maintained	Lamp/LED bulb	A0214X
○	Illum, momentary	Special LED assy	A0213Y
○	Illum, maintained	Special LED assy	A0213X
○	Non-illum, momentary		A0215Y
○	Non-illum, maintained		A0215X
○	Illum, indicator	Lamp/LED bulb	A02791
○	Illum, indicator	Special LED assy	A02792

Std bezel material : silver anodised aluminium.
For optional black anodised aluminium, add 'G' to the end of **operator** model number.

Unsealed switches (IP40):
add '01' to end of **operator** model number

Screen engraving/insertable legends:
contact APEM Components

Switch block

Contacts	Part No
1 N.O.	A02501
1 N.C.	A02502
2 N.O.	A02503
2 N.C.	A02504
1 N.O./1 N.C.	A02505

Second switch block

Contacts	Part No
1 N.O.	A02506
1 N.C.	A02507
2 N.O.	A02508
2 N.C.	A02509
1 N.O./1 N.C.	A02510

To achieve 3 or 4 pole switching, add second switch block from above table.

Bezel: □ rectangular □ square ○ round. 'Illum' - illuminated, 'Non-illum' - non illuminated

A02 SERIES INDICATORS

Panel cut-out Ø22 or 29.5 x 21.5

An indicator assembly requires:

screen + lamp, LED bulb or LED assembly + operator

To order these elements, select desired model numbers from tables below.

Example: rectangular indicator with red screen and 12V red LED assembly
= A0261B, A0242J1 and A0272

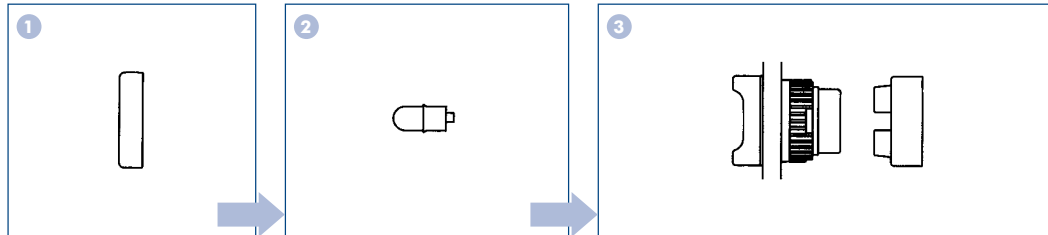
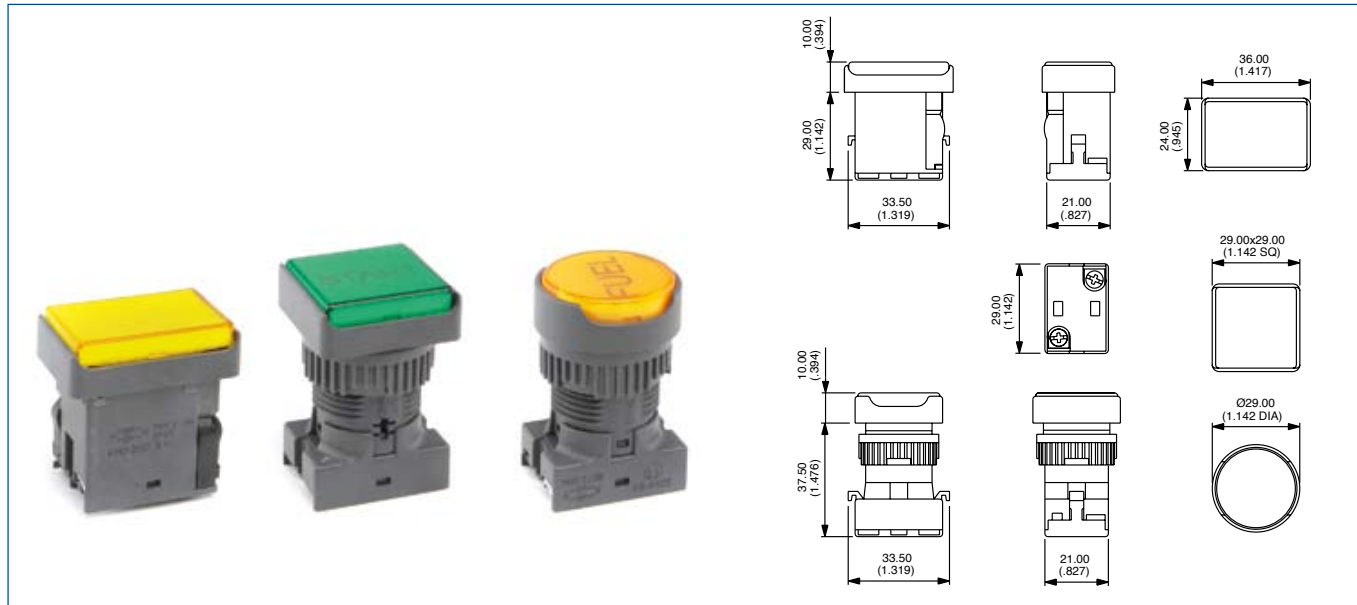

Screen

Bezel	Colour	Part No
<input type="checkbox"/>	black	A0261A
<input type="checkbox"/>	red	A0261B
<input type="checkbox"/>	amber	A0261C
<input type="checkbox"/>	yellow	A0261D
<input type="checkbox"/>	green	A0261E
<input type="checkbox"/>	blue	A0261F
<input type="checkbox"/>	clear	A0261G
<input type="checkbox"/>	white	A0261J
<input type="checkbox"/>	black	A0262A
<input type="checkbox"/>	red	A0262B
<input type="checkbox"/>	amber	A0262C
<input type="checkbox"/>	yellow	A0262D
<input type="checkbox"/>	green	A0262E
<input type="checkbox"/>	blue	A0262F
<input type="checkbox"/>	clear	A0262G
<input type="checkbox"/>	white	A0262J
<input type="checkbox"/>	black	A0263A
<input type="checkbox"/>	red	A0263B
<input type="checkbox"/>	amber	A0263C
<input type="checkbox"/>	yellow	A0263D
<input type="checkbox"/>	green	A0263E
<input type="checkbox"/>	blue	A0263F
<input type="checkbox"/>	clear	A0263G
<input type="checkbox"/>	white	A0263J

Lamp

Lamp	Voltage	Part No
Filament	6.3V	A0141A
Filament	14V	A0141B
Filament	28V	A0141C
Filament	36V	A0141D
Filament	48V	A0141E
Filament	60V	A0141F
Neon	110V	A0143G
Neon	220V	A0143H
LED lamp	model numbers	see Pages 6&7
Special LED Assemblies		
LED assy	<input type="checkbox"/> 6V	A0242H*
LED assy	<input type="checkbox"/> 12V	A0242J*
LED assy	<input type="checkbox"/> 24V	A0242K*
LED assy	<input type="checkbox"/> 6V	A0243H*
LED assy	<input type="checkbox"/> 12V	A0243J*
LED assy	<input type="checkbox"/> 24V	A0243K*
LED assy	<input type="checkbox"/> 6V	A0244H*
LED assy	<input type="checkbox"/> 12V	A0244J*
LED assy	<input type="checkbox"/> 24V	A0244K*
NB Replace * with colour code		
for LED assemblies: 1: red		
2: green		
3: amber		

Operator

Bezel	Description	Lamp type	Part No
<input type="checkbox"/>	Indicator	Lamp/LED bulb	A0271
<input type="checkbox"/>	Indicator	Special LED assy	A0272
<input type="checkbox"/>	Indicator	Lamp/LED bulb	A0273
<input type="checkbox"/>	Indicator	Special LED assy	A0274
<input type="checkbox"/>	Indicator	Lamp/LED bulb	A0275
<input type="checkbox"/>	Indicator	Special LED assy	A0276

White or Blue LED Assembly:

contact APEM Components

Screen engraving/insertable legends:

contact APEM Components

Unsealed indicators (IP40):

add '01' to end of operator model number

Bezel: rectangular square round

A02 SERIES

ROTARY SWITCHES

Panel cut-out Ø22 (.866)

A rotary lever assembly requires:

operator + one or two switchblocks

To order these elements, select desired model numbers from tables below.

Example: IP65 square 2 position maintained rotary switch with long lever, switch block with 2 N.O. contacts = A029101 and A02503.

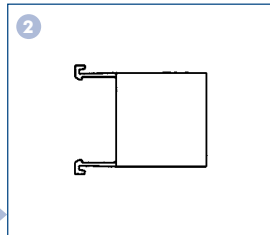
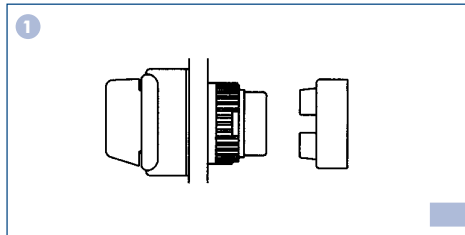
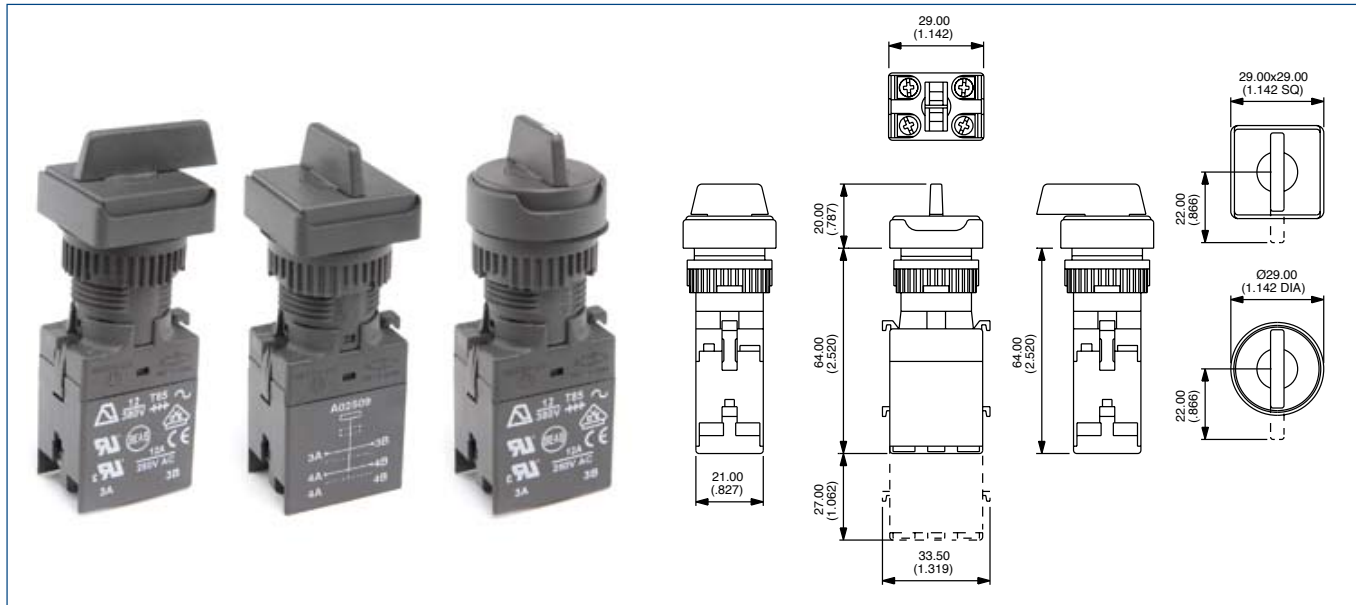
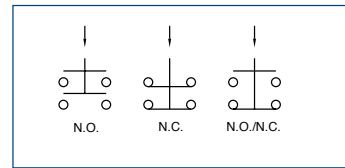

Lever Positions

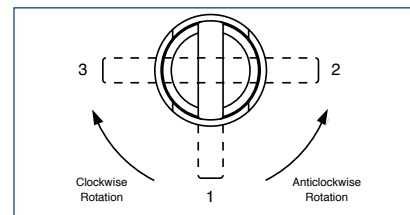

Operator

Bezel	Description	Short lever	Long lever
<input type="checkbox"/>	2 pos. maintained	A029201	A029101
<input type="checkbox"/>	2 pos. momentary	A029202	A029102
<input type="checkbox"/>	3 pos. maintained	A029203	A029103
<input type="checkbox"/>	3 pos. momentary	A029204	A029104
<input type="checkbox"/>	3 pos. mainL, momR	A029205	A029105
<input type="checkbox"/>	3 pos. momL, mainR	A029206	A029106
<input type="radio"/>	2 pos. maintained	A029401	A029301
<input type="radio"/>	2 pos. momentary	A029402	A029302
<input type="radio"/>	3 pos. maintained	A029403	A029303
<input type="radio"/>	3 pos. momentary	A029404	A029304
<input type="radio"/>	3 pos. mainL, momR	A029405	A029305
<input type="radio"/>	3 pos. momL, mainR	A029406	A029306

Switch block

Contacts	Part No
1 N.O.	A02501
1 N.C.	A02502
2 N.O.	A02503
2 N.C.	A02504
1 N.O./1 N.C.	A02505

Second switch block

Contacts	Part No
1 N.O.	A02506
1 N.C.	A02507
2 N.O.	A02508
2 N.C.	A02509
1 N.O./1 N.C.	A02510

To specify flush mounting (30mmØ) option: add 'FM' to the end of the part number:

Example: A029401FM (round operators only)

To achieve 3 or 4 pole switching, add second switch block from above table.

• Lever Rotation – 2 position switches

The model numbers shown are for switches with anticlockwise lever rotation.

For clockwise rotation, replace:

01 with 07
02 with 08

at the end of the model number

Optional Engraving on Lever End



To order add 'WL' to the end of the part number.

Example: A029401WL

Bezel: square round

A02 SERIES

KEYLOCK SWITCHES

Panel cut-out $\text{Ø}22$ or 29.5×21.5

A keylock assembly requires:

operator + one or two switchblocks

To order these elements, select desired model numbers from tables below.

Example: IP65 square 2 position maintained keyswitch, switch block with 2 N.O. contacts = A028201 and A02503

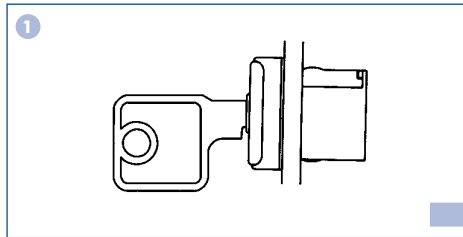
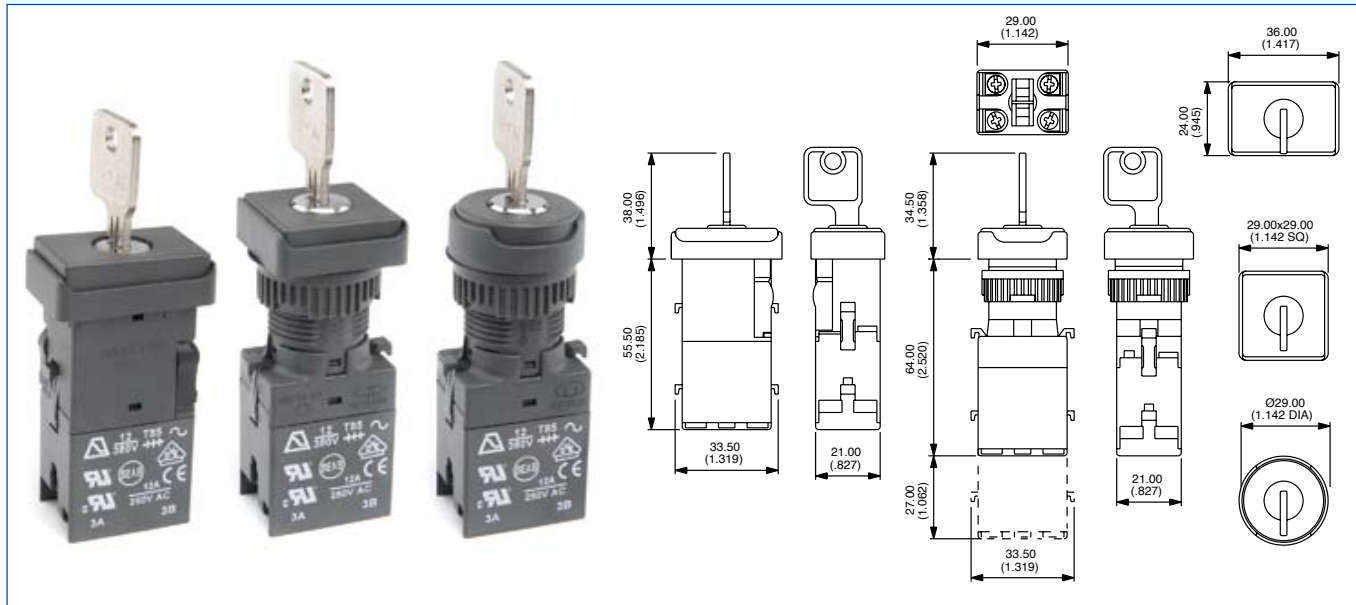
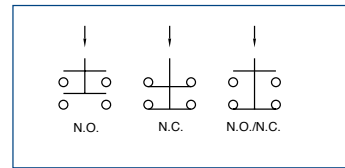

Operator

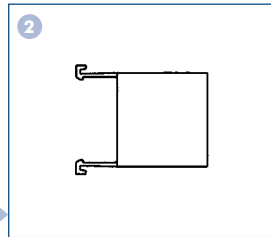

Switch block

Key Positions

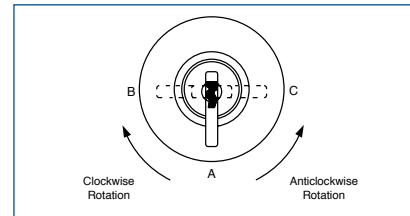

Key Rotation – 2 position switches

The model numbers shown are for switches with anticlockwise lever rotation.

For clockwise rotation, replace:

01 with 20
02 with 19

at the end of the model number

- 2 standard keys are supplied
- 20 key barrel types available from stock
- Non-removable key positions: contact APEM components

Bezel	Description	Part No.	Key removable in positions
<input type="checkbox"/>	2 pos. maintained	A028101	A-C
<input type="checkbox"/>	2 pos. momentary	A028102	A
<input type="checkbox"/>	3 pos. maintained	A028105	A-B-C
<input type="checkbox"/>	3 pos. momentary	A028106	A
<input type="checkbox"/>	3 pos. mainL, momR	A028107	A-B
<input type="checkbox"/>	3 pos. momL, mainR	A028108	A-C
<input type="checkbox"/>	2 pos. maintained	A028201	A-C
<input type="checkbox"/>	2 pos. momentary	A028202	A
<input type="checkbox"/>	3 pos. maintained	A028205	A-B-C
<input type="checkbox"/>	3 pos. momentary	A028206	A
<input type="checkbox"/>	3 pos. mainL, momR	A028207	A-B
<input type="checkbox"/>	3 pos. momL, mainR	A028208	A-C
<input type="checkbox"/>	2 pos. maintained	A028301	A-C
<input type="checkbox"/>	2 pos. momentary	A028302	A
<input type="checkbox"/>	3 pos. maintained	A028305	A-B-C
<input type="checkbox"/>	3 pos. momentary	A028306	A
<input type="checkbox"/>	3 pos. mainL, momR	A028307	A-B
<input type="checkbox"/>	3 pos. momL, mainR	A028308	A-C

Contacts	Part No
1 N.O.	A02501
1 N.C.	A02502
2 N.O.	A02503
2 N.C.	A02504
1 N.O./1 N.C.	A02505

Second switch block

Contacts	Part No
1 N.O.	A02506
1 N.C.	A02507
2 N.O.	A02508
2 N.C.	A02509
1 N.O./1 N.C.	A02510

To achieve 3 or 4 pole switching, add second switch block from above table.

To specify flush mounting (30mm Ø) option: add 'FM' to the end of the part number:
Example: A028301FM (round operator only)

Bezel: rectangular square round. 'pos' - position, 'mainL' - maintained left 'momR' - momentary right, etc

A02 SERIES

EMERGENCY STOP SWITCHES

Panel cut-out Ø22 (.866)

- Prominent 40mm (1.575) dia. red mushroom actuator
- Highly reliable positive break switch
- Push to shut off switch, twist to reset to ON

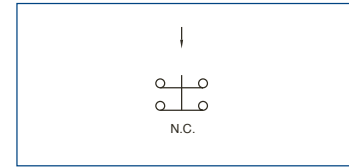

An emergency stop switch assembly requires:

operator + switch block
 To order specify with single pole or double pole positive break switch block.
 Approved to UL1054/EN 60947-5-5

General Specifications

Min Mechanical Life	: 6050 cycles (6 cycles per minute)
Operating Force	: 20N
Operating Temperature	: -20°C to +85°C
Degree of Environmental Protection (IEC 529)	: IP65 front of panel IP40 back of panel
Switch Terminals	: M3 screws-wire 2 x 0.75mm ² max

Electrical Specifications

Current/Voltage rating	: 2.5A 380VAC AC-15
Contact Gap	: >3mm
Dielectric test voltage	: 2500V
Electrical Life	: >6050

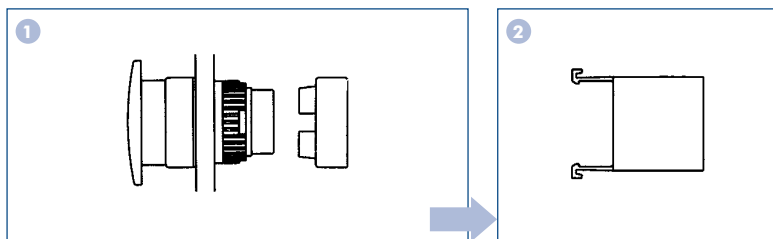
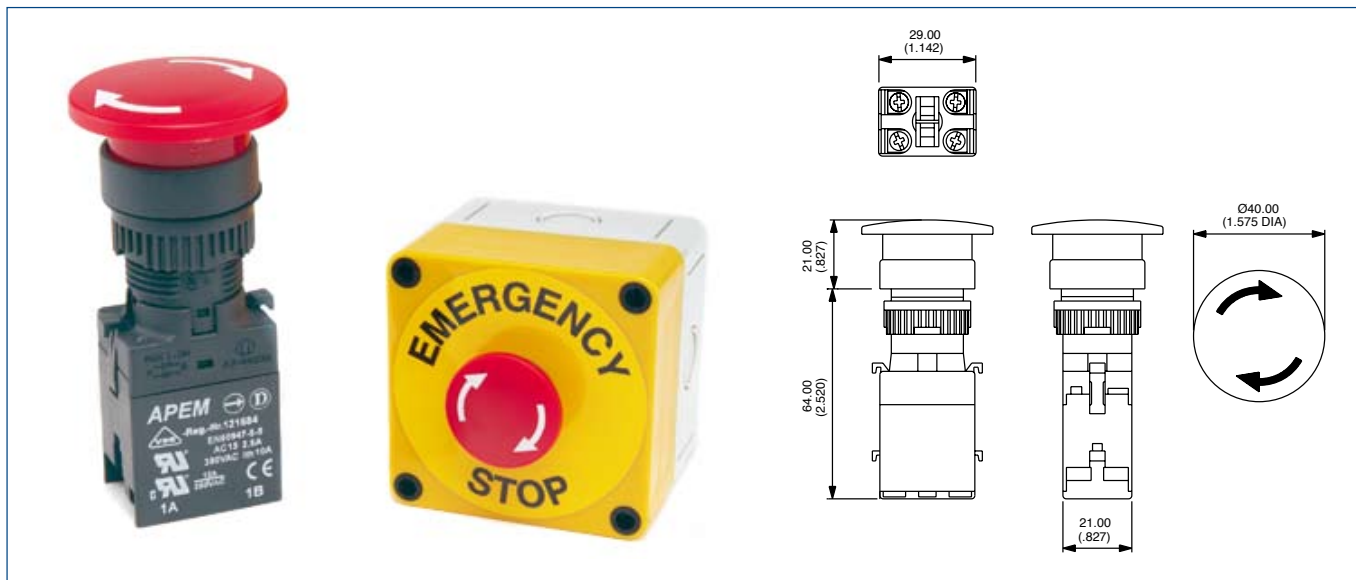

Operator

Bezel	Description	Part No
○	E-Stop operator	A02ES

Switch block

No of poles	Part No
Double pole	A02511
Single pole	A02512

Accessories



90Ø Self Adhesive Label

Description	Part No
Yellow label with text	A02YL1
Yellow label	A02YL2

To order the Emergency Stop Switch in the Plastic Enclosure with a 2 Pole Positive break Switchblock and Emergency Stop label use **part number: A02PE2L**

Bezel: ○ round.

A02 SERIES

MUSHROOM HEAD PUSHBUTTON SWITCHES

Panel cut-out Ø22 (.866)

- Prominent 40mm (1.575) dia. mushroom actuator
- Momentary and maintained functions, momentary function versions are unmarked, maintained function versions are twist to release (arrows indicate direction of twist)
- Various coloured mushroom actuators are available

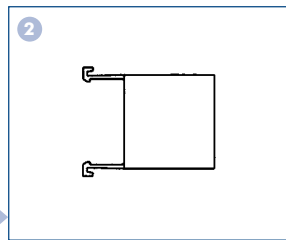
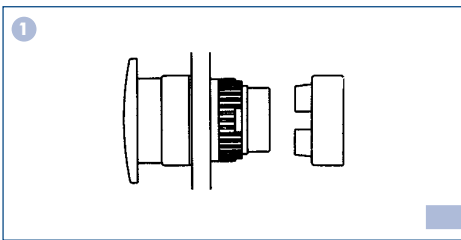
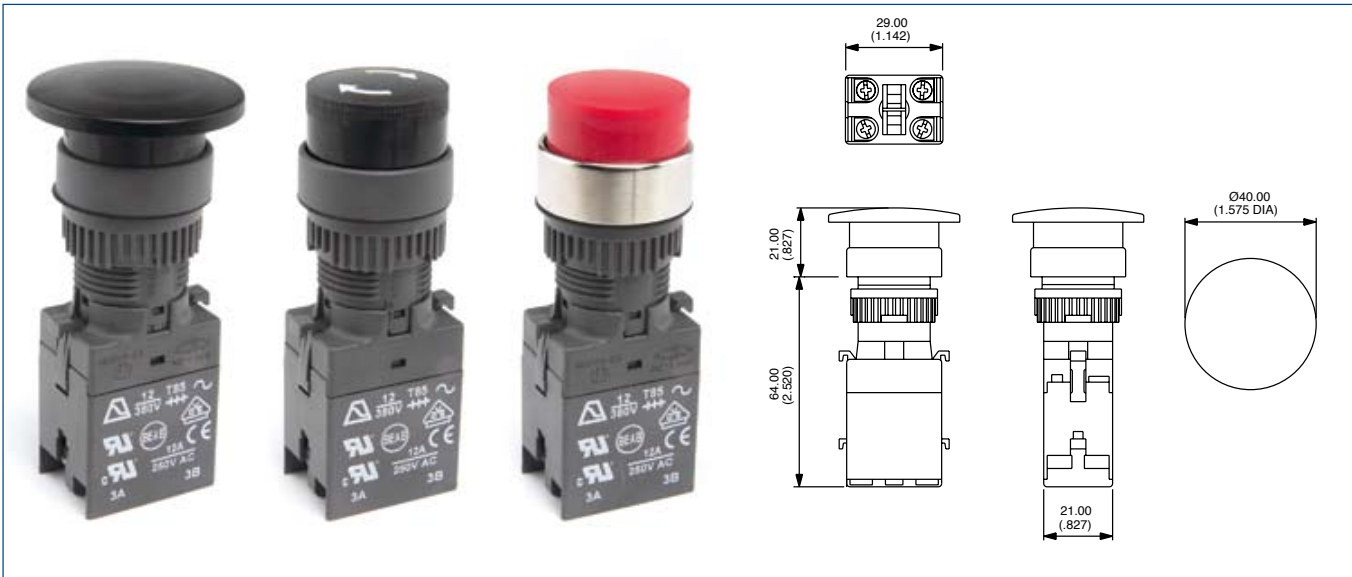
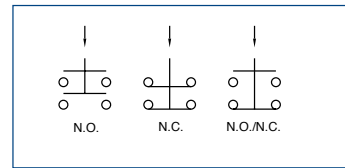

Operator

Bezel	Description	Part No
○	Black momentary	A02MMA
○	Red momentary	A02MMB
○	Yellow momentary	A02MMD
○	Green momentary	A02MME
○	Blue momentary	A02MMF
○	Black maintained	A02MXA
○	Red maintained	A02MXB
○	Yellow maintained	A02MXD
○	Green maintained	A02MXE
○	Blue maintained	A02MXF

Switch block

Contacts	Part No
1 N.O.	A02501
1 N.C.	A02502
2 N.O.	A02503
2 N.C.	A02504
1 N.O./1 N.C.	A02505

Second switch block

Contacts	Part No
1 N.O.	A02506
1 N.C.	A02507
2 N.O.	A02508
2 N.C.	A02509
1 N.O./1 N.C.	A02510

For optional reduced (Ø26mm) mushroom head operators: contact APEM Components

To achieve 3 or 4 pole switching, add second switch block from above table.

Bezel: ○ round.

A02 SERIES

INDUSTRIAL CONTROLS

Installation

Modular Construction/panel mounting

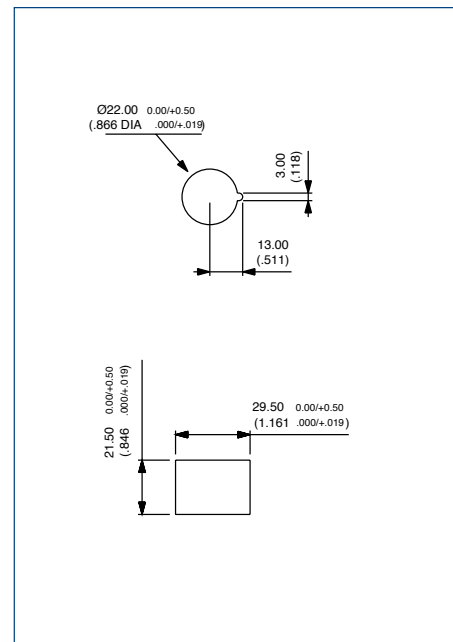
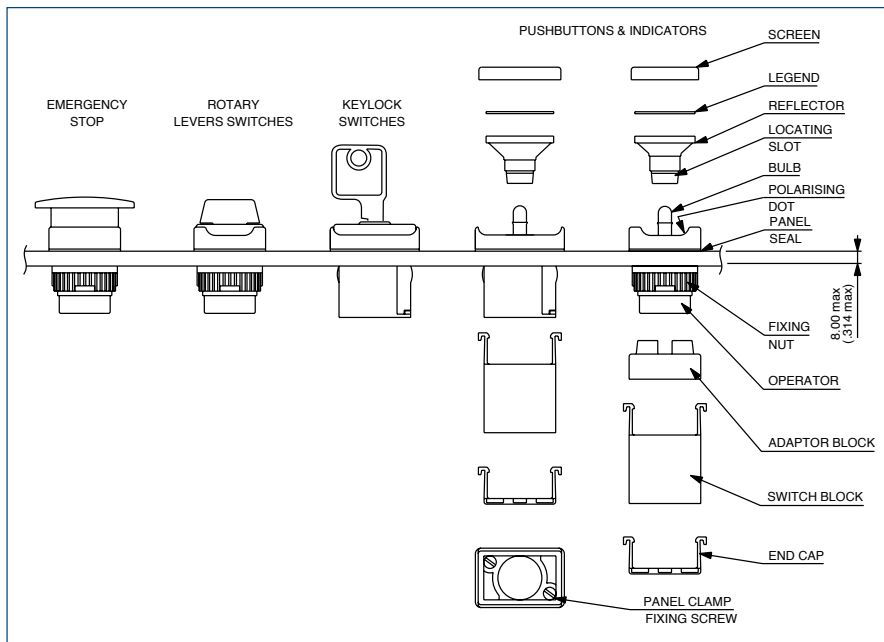

PANEL MOUNTING ASSEMBLY

- Drill/punch hole in panel as shaped above.
- Assemble front operator through hole and:
 - a) *Round & Square types*: tighten nut to a maximum torque of 0,8Nm using tool No. 30-0001. Snap on adaptor block
 - b) *Rectangular types*: tighten two panel fixing screws in front to a maximum torque of 6cNm.
- Wire chosen switch block as required and snap onto front operator.
- Snap end cap onto switch block (optional).
- Fit bulb if required using tool No. 30-0002.
- Snap screen onto reflector assembly with legend in between if required and snap onto front operator **TAKING CARE TO LINE UP THE LOCATING SLOT WITH THE POLARISING DOT, and not to damage the seal.**

TO REMOVE BULB

Remove reflector/screen assembly. Use the bulb extractor 30-0002 to remove the bulb.

TO REMOVE SWITCH BLOCK

Lever out latches using small screwdriver taking care not to overbend, and pull off the block from the front of operator.

A02 Accessories

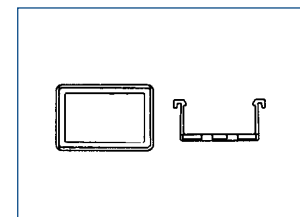

End cap terminal guard
offering unique terminal protection.
Part No. 14-0005



6.35mm Push on tab terminals
Specify 'SP' to the end of the switchblock and operator part No.
Example: A02503SP

Dimensions: First dimensions are in mm while inches are shown in bracketed numbers.

Tolerance: The general tolerance for dimensions in this catalogue is +/- 0,3 (.012).

Dimensions, specifications and data shown in this catalogue are subject to change without notice.