

SHEET OF

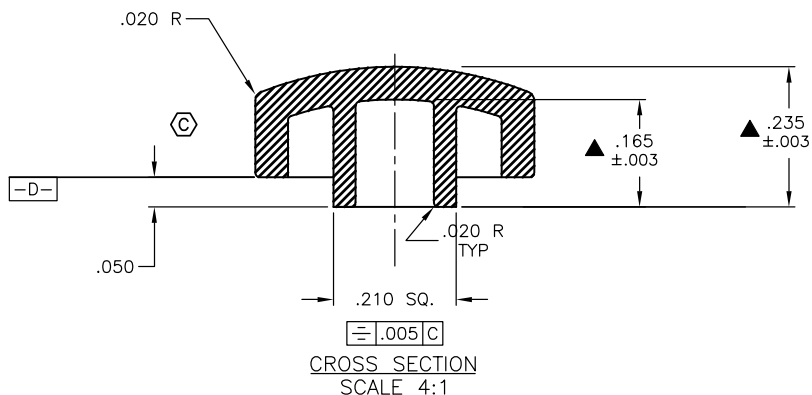
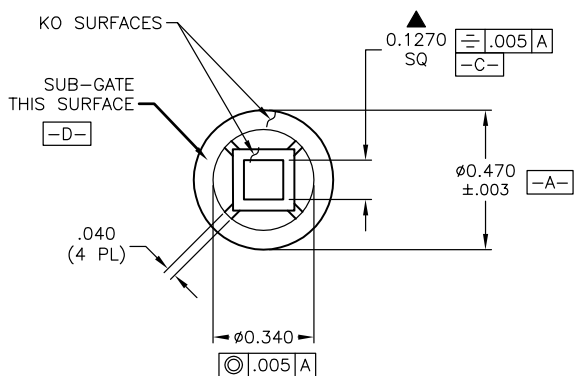
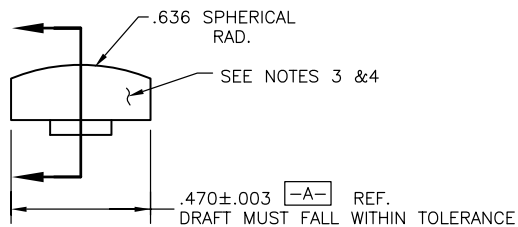

- NOTES:
1. ALL DIMENSIONS IN INCHES
 2. MATERIAL: ABS RTP600 SC89871A
COLOR GRAY
 - ▲ 3. EXTERNAL SURFACES TO BE FREE OF SINK MARKS & BLEMISHES
 - ▲ 4. SURFACE FINISH: FINE EDM MACHINE FINISH
 5. ▲ DESIGNATE MAJOR FEATURE:
 6. UNLESS OTHERWISE SPECIFIED TOLERANCE TO BE ±.005

C	14446	REMOVE DIM	11/2/04	AR
B	12555	DIMENSION CHANGE	11/13/02	CB
A	11567	RELEASED FOR PRODUCTION	2/12/02	CB
REV.	ECN No.	DESCRIPTION	DATE	CHKD

THE INFORMATION CONTAINED IN THIS DOCUMENT IS PROPRIETARY TO E-SWITCH AND IS NOT TO BE COPIED OR TRANSFERRED

E-SWITCH®				
TITLE 320.08 CAP GRAY				
SCALE	DATE	DR	DWG	REV
2:1	2/12/02	CB	B099407	C