

4

3

2

1

THIS DRAWING IS UNPUBLISHED. RELEASED FOR PUBLICATION  
 © COPYRIGHT - BY TYCO ELECTRONICS CORPORATION. ALL RIGHTS RESERVED.

LOC		DIST		REVISIONS			
P	LTR	DESCRIPTION		DATE	DWN	APVD	
	B	REVISED PER ECO-07-029489		2/22/08	SS	MW	

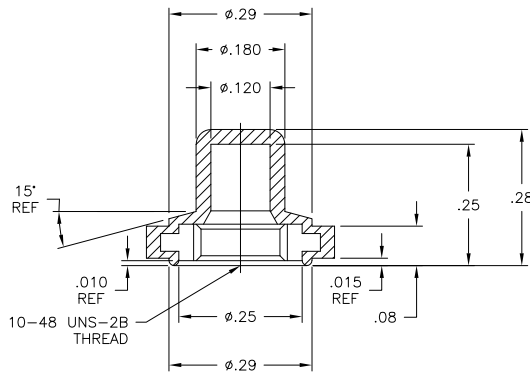
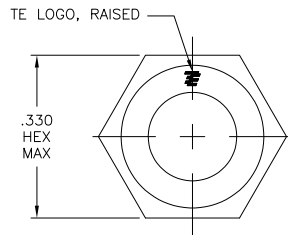

- SOME DIMENSIONS MAY VARY DUE TO DIFFERENT COMPOUND SHRINKAGE FACTOR.
- MINOR FLASH ACCEPTABLE ON INSERT THREAD.
- BLACK FINISH/NICKEL PLATING INSIDE THREADS REMOVED DUE TO MOLDING PROCESS PERMITTED.
- RUBBER TO METAL BOND MUST MEET OR EXCEED THE TEAR STRENGTH OF RUBBER.
- COMPONENTS MUST COMPLY WITH THE EUROPEAN DIRECTIVE 2002/95/EC ON RESTRICTION OF THE USE OF CERTAIN HAZARDOUS SUBSTANCES IN ELECTRICAL AND ELECTRONIC EQUIPMENT (ROHS DIRECTIVE).

OBSOLETE	-	BRASS, NICKEL PLATE PER QQ-N-290	SILICONE, COLOR GRAY	1825615-3
BP1048204	-	BRASS, NICKEL PLATE PER QQ-N-290	SILICONE, COLOR RED	1825615-2
BP1048004	-	BRASS, BLACK OXIDE PER MIL-F-495	SILICONE, COLOR BLACK	1825615-1
ALCO NUMBER		HEX NUT MATERIAL	RUBBER BOOT MATERIAL	PART NUMBER

THIS DRAWING IS A CONTROLLED DOCUMENT.		DWN S SCHLEGEL 22FEB2008	Tyco Electronics Tyco Electronics Corporation Harrisburg, PA 17105-3608	
DIMENSIONS: INCHES		CHK M WILBOURN 2/22/08	NAME 10-48 PUSHBUTTON BOOT SEAL	
TOLERANCES UNLESS OTHERWISE SPECIFIED:		APVD M WILBOURN 2/22/08	RESTRICTED TO	
0 PLC ± -		PRODUCT SPEC	SIZE	
1 PLC ± -		APPLICATION SPEC	CAGE CODE	DRAWING NO
2 PLC ± .01		WEIGHT	A3	00779
3 PLC ± .005		CUSTOMER DRAWING	C	1825615
4 PLC ± -		SCALE	5:1	SHEET
ANGLES ± 5'		1 OF 1	REV	B
MATERIAL	FINISH			