

4

3

2

1

THIS DRAWING IS UNPUBLISHED. RELEASED FOR PUBLICATION  
 © COPYRIGHT BY TYCO ELECTRONICS CORPORATION. ALL RIGHTS RESERVED.

LOC	DIST	REVISIONS		
P	LTR	DESCRIPTION	DATE	BY
B		REVISED PER ECO-07-029492	2/22/08	SS MW

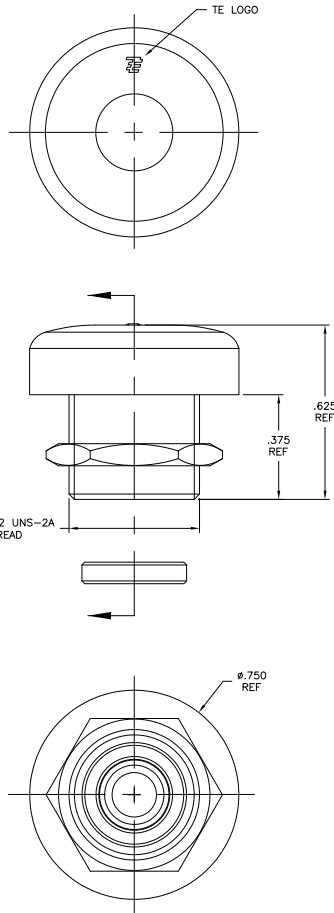

- COMPONENTS MUST COMPLY WITH EUROPEAN DIRECTIVE 2002/95/EC ON RESTRICTION OF THE USE OF CERTAIN HAZARDOUS SUBSTANCES IN ELECTRICAL AND ELECTRONICS EQUIPMENT (ROHS DIRECTIVE).
- SUPPLIED WITH JAM NUT ASSEMBLED AND SPACER IN PACKAGE BAG.

BPM1532804	GRAY	SILICONE PER ZZ-R-765, CLASS 3A, GRADE 60	1825618-3
BPM1532204	RED	SILICONE PER ZZ-R-765, CLASS 3A, GRADE 60	1825618-2
BPM1532004	BLACK	SILICONE PER ZZ-R-765, CLASS 3A, GRADE 60	1825618-1
ALCO NUMBER	CAP COLOR	CAP MATERIAL	PART NUMBER

THIS DRAWING IS A CONTROLLED DOCUMENT.

DESIGNED BY: S. SCHLEGEL	DATE: 2/22/08	APPROVED BY: M. WILBOURN	DATE: 2/22/08
DRAWN BY: M. WILBOURN		NAME: M. WILBOURN	
PRODUCT SPEC: ---			
APPLICATION SPEC: ---		SIZE: A2	CAGE CODE: 00779
MATERIAL: ---		DRAWING NO: C=1825618	
FINISH: ---		SCALE: 4:1	SHEET: 1 of 1
CUSTOMER DRAWING			

1825618