

4

3

2

1

THIS DRAWING IS UNPUBLISHED. RELEASED FOR PUBLICATION  
 © COPYRIGHT BY TYCO ELECTRONICS CORPORATION. ALL RIGHTS RESERVED.

LOC		DIST		REVISIONS			
P	LTR	DESCRIPTION		DATE	DWN	APVD	
B	1	REVISED PER ECO-08-019381		07AUG08	HMR	MW	

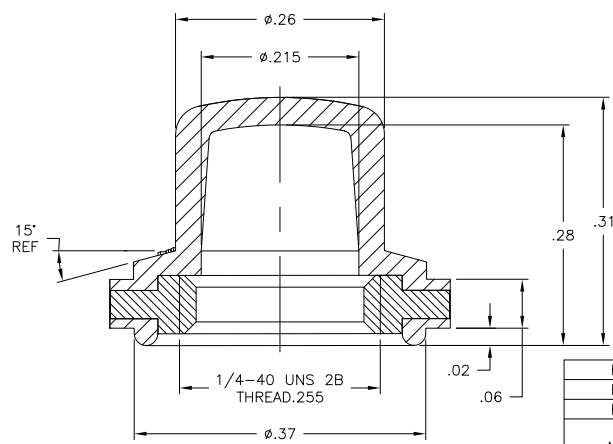
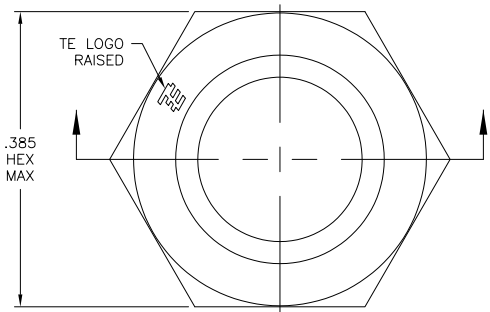

- SOME DIMENSIONS MAY VARY DUE TO DIFFERENT COMPOUND SHRINKAGE FACTOR.
- MINOR FLASH ACCEPTABLE ON INSERT THREAD.
- BLACK FINISH/NICKEL PLATING ON INSIDE THREADS REMOVED DUE TO MODEL PROCESS PERMITTED.
- RUBBER TO METAL BOND MUST MEET OR EXCEED THE TEAR STRENGTH OF RUBBER.
- RUBBER OVERLAY PERMISSIBLE OVER HEX FLATS AS SHOWN IN THE DRAWING.
- COMPONENTS MUST COMPLY WITH THE EUROPEAN DIRECTIVE 2002/95/EC ON RESTRICTION OF THE USE OF CERTAIN HAZARDOUS SUBSTANCES IN ELECTRICAL AND ELECTRONIC EQUIPMENT (ROHS DIRECTIVE).

BPA1440804	SILICONE, COLOR GRAY	BRASS, NICKEL PLATE PER QQ-N-290	1825604-3
BPA1440204	SILICONE, COLOR RED	BRASS, NICKEL PLATE PER QQ-N-290	1825604-2
BPA1440004	SILICONE, COLOR BLACK	BRASS, BLACK OXIDE PER MIL-F-495	1825604-1
ALCO NUMBER	RUBBER BOOT MATERIAL	HEX NUT MATERIAL	PART NUMBER

THIS DRAWING IS A CONTROLLED DOCUMENT. 03MAR2008

DWN S SCHLEGEL	3/3/08	Tyco Electronics Corporation Harrisburg, PA 17105-3608
CHK M WILBOURN	3/3/08	
APVD M WILBOURN	3/3/08	NAME MINIATURE 1/4-40 PUSHBUTTON BOOT SEAL
DIMENSIONS: INCHES		SIZE A3
TOLERANCES UNLESS OTHERWISE SPECIFIED: 0 PLC ± - 1 PLC ± - 2 PLC ± .01 3 PLC ± .005 4 PLC ± - ANGLES ± 5'		CAGE CODE 00779
MATERIAL		DRAWING NO C=1825604
FINISH		RESTRICTED TO
CUSTOMER DRAWING		SCALE 8:1
		SHEET 1 of 1
		REV B1