



Made in America

Touch Tester - Operation, Installation and Calibration Instructions

Pass Range 750K Ohms to 10 Megohm 120VAC Operation



Figure 1. Model [19350](#) Wrist Strap Tester / Common Point Ground

Description

Per ANSI/ESD S20.20, test equipment is required to enact Compliance Verification Plan Requirement. Test equipment shall be selected to make measurements of appropriate properties of the technical requirements that are incorporated into the ESD program plan.

The Touch Tester is an “on demand” wrist strap tester that also functions as a common-point ground for two wrist straps and a mat. When the wearer of a wrist strap touches the metallic surface of the Touch Tester, a path for current flow is completed from the wearer’s skin, through the wrist strap, to the metallic surface to ground. This action will cause the green “test good” LED to light (and the optional audible signal to sound) as long as the resistance of the circuit path is between 750k ohms and 10 megohms.

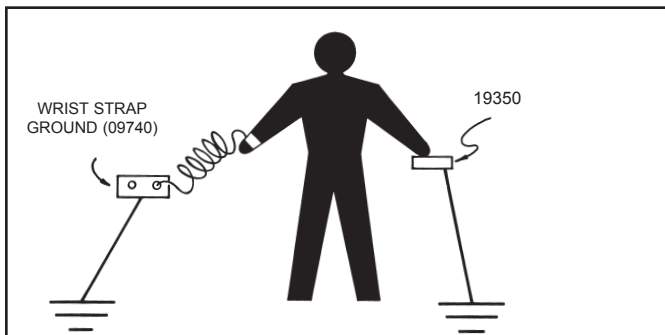

Figure 2. [19350](#) Testing Circuit

The wrist strap being tested may be plugged directly to the tester or any convenient common ground point. The wrist strap will test properly as long as both the Touch Tester and the wrist strap are connected to a common ground. Therefore, any number of wrist strap wearers may use the Touch Tester if they can conveniently reach it. Desco item [09740](#) provides two banana jacks for grounding wrist straps.

When the Touch Tester and a [09740](#) are tied to a common ground (utility ground) wrist straps plugged into the [09740](#) can also be tested.

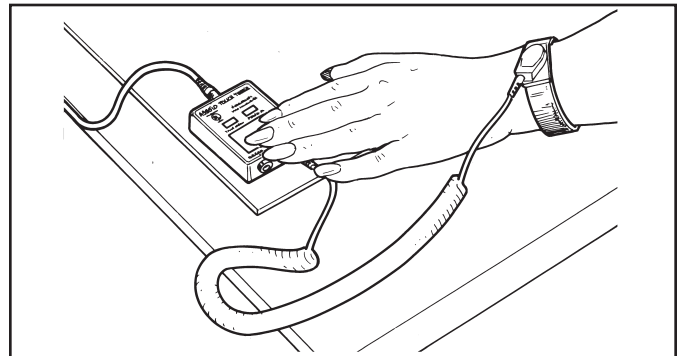

Figure 3. Testing a wrist strap

Installation

The Touch Tester is easily attached at the workstation. A snap stud at ground reference is provided on the back of the unit, allowing it to be snapped directly to a mat. In this configuration, the unit provides a common-point ground for both the mat and the wrist strap, and is easily accessible for frequent testing. A piece of adhesive backed hook and loop fastener is provided for the user as an alternative mounting method preventing the tester from rotating.

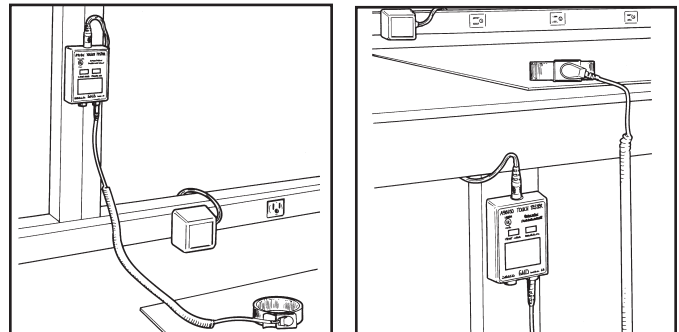

Figure 4. Installation of Touch Tester

The hook-and-loop type fastener also allows fast mounting to smooth surfaces. This method is convenient for mounting the tester on a workstation leg or on an upright support for shelving or lights. (Note - the snap does not have to be connected for proper grounding).

Equipment Rating:

AC Adapter rated 120 Vac, 60 Hz, 6 W.
Ground Touch Tester rated 6.5 Vdc, 50 mA.

Environmental Conditions

- Suitable for indoor use only at altitudes not exceeding 6500 ft. (2Km)
- Temperature range of 41°F (5°C) to 104°F (40°C)
- Maximum relative humidity of 80% up to 88°F (31°C) decreasing linearly to 50% @ 104°F (40°C)
- Pollution degree 2 per IEC 664
- Installation Category II

CAUTION: If this equipment is used in a manner not specified by the manufacturer, the protection provide by the equipment may be impaired.

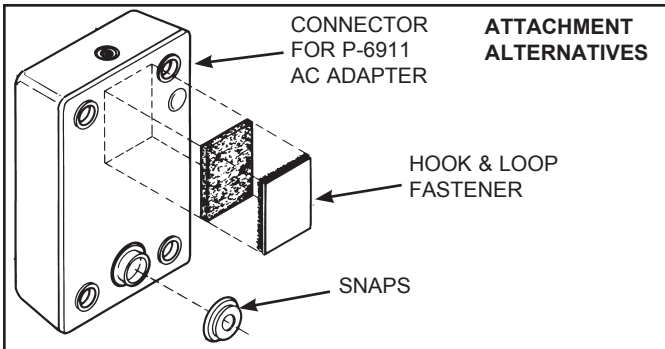

Figure 5. Attachment alternatives

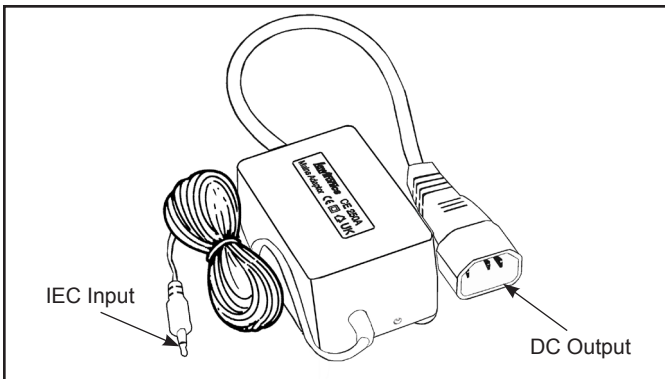

Figure 6. AC Adapter, 220 Volt

Operation

When the Touch Tester's power supply is plugged into a grounded outlet the red LED will be on, indicating that the unit is powered. The utility ground is internally connected to the .395" (10mm) snap stud on the back of the unit and to the 2 banana jacks at the bottom edge of the tester.

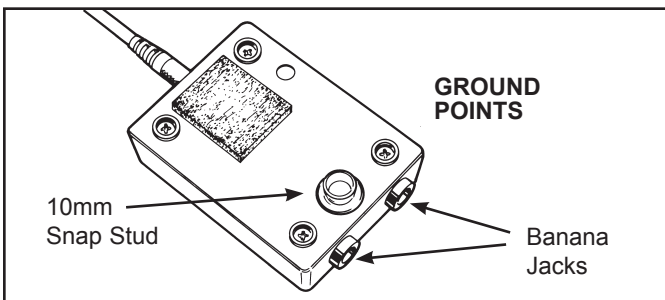

Figure 7. Ground points

A wrist strap is plugged into one of the banana jacks or into any common grounding point. When the wearer of a wrist strap touches the metallic test surface, the green "test good" LED will light if the operator-to-ground resistance is between 750k ohms and 10 megohms.

Proper Ground

The integrity of the utility ground must be tested before the Touch Tester is plugged in. The Touch Tester utilizes the "green wire" ground as the static ground. Each outlet must be tested for proper grounding prior to use. Outlets can become ungrounded over time due to corrosion, wear, or vibration.

Desco recommends our model [98130](#) AC Outlet Analyzer & Wrist Strap Tester when testing electrical outlets for proper grounding and wiring. For detailed information on the [98130](#), ask for Technical Bulletin [TB-2099](#).

Audible Option

If desired, the Touch Tester will augment the visual "test good" indicator with an audible signal. In the "on" position, the tester will beep when the green "test good" LED is on, thereby allowing the operator to frequently test the wristband and cord without having to look at the tester.

To enable/disable the signal, a slide switch is accessible through the hole on the back of the unit. First, unplug the power supply. Actuate the switch with a small probing tool, being careful to avoid internal damage.

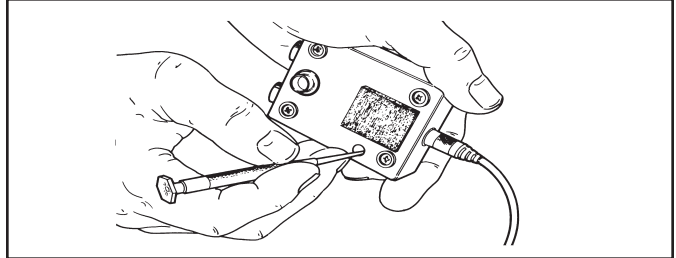

Figure 8. Accessing the audible signal

Calibration

We recommend annual calibration of our testers. The model [19350](#) is calibrated to NIST traceable standards. Calibration may be performed to ensure that the tester is operating within limits.

Desco offers a calibration unit that is specifically designed to simplify the calibration procedure. This unit is sold as item [#07010](#). The [07010](#) comes calibrated to NIST traceable standards. Ask for Technical Bulletin TB-2039 for detailed procedure to calibrate the 19350. If you are familiar with the procedure, the following resistance should give the display shown:

Resistance Value (±1%)

675 Kilohms:
825 Kilohms:
8.5 Megohms:
11.5 Megohms:

Test Output

Red (Low-hazard)
Green (OK-in limits)
Green (OK-in limits)
Red (High resistance)

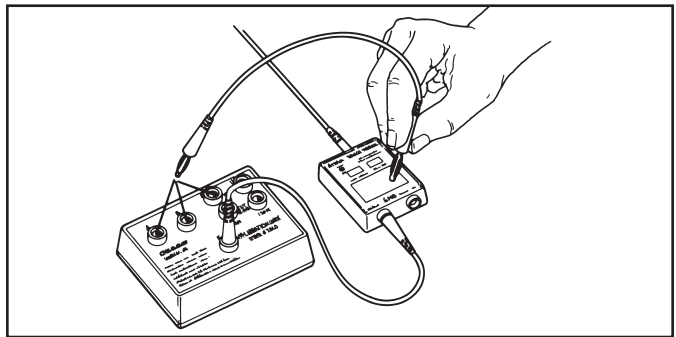

Figure 9. Calibration of tester

LIMITED WARRANTY

Desco expressly warrants that for a period of one (1) year from the date of purchase, Desco Touch Testers will be free of defects in material (parts) and workmanship (labor). Within the warranty period, a unit will be tested, repaired or replaced at Desco's option, free of charge. Call Customer Service at 909-627-8178 (Walnut, CA) or (781) 821-8370 (Canton, MA) for a Return Material Authorization (RMA), and proper shipping instructions and address. You should include a copy of your original packing slip, invoice, or other proof of purchase. Any unit under warranty should be shipped prepaid to the Desco factory. Warranty replacements will take approximately two weeks.

WARRANTY EXCLUSIONS

THE FOREGOING EXPRESS WARRANTY IS MADE IN LIEU OF ALL OTHER PRODUCT WARRANTIES, EXPRESSED AND IMPLIED, INCLUDING MERCHANTABILITY AND FITNESS FOR A PARTICULAR PURPOSE WHICH ARE SPECIFICALLY DISCLAIMED. The express warranty will not apply to defects or damage due to accidents, neglect, misuse, alterations, operator error, or failure to properly maintain, clean or repair products.

LIMIT OF LIABILITY

In no event will Desco or any seller be responsible or liable for any injury, loss or damage, direct or consequential, arising out of the use of or the inability to use the product. Before using, users shall determine the suitability of the product for their intended use, and users assume all risk and liability whatsoever in connection therewith.