

MINIATURE PRESSURE SENSORS

Barometric Pressure Sensors Prime Grade



Features

- 600 to 1,100 mbar Pressure Range
- 0.25 % linearity
- Temperature Compensated
- Calibrated Zero and Span

Applications

- Medical Instrumentation
- Environmental Controls
- Weather Station
- Altimeters

General Description

The Miniature series pressure sensors are based upon a proprietary technology to reduce the size of the sensor and yet maintain a high level of performance. This model provides a calibrated millivolt output with superior output characteristics. In addition the sensor utilizes a silicon, micromachined (MEMS) structure to provide a very linear output to measured pressure.

These calibrated and temperature compensated sensors give an accurate and stable output over a wide temperature range. This series is intended for use with non-corrosive, non-ionic working fluids such as air, dry gases and the like. The PRIME GRADE is the highest accuracy version of the millivolt output pressure sensors.

The output of the device is ratiometric to the supply voltage and operation from any D.C. supply voltage to 16 volts.

Pressure Sensor Characteristics Maximum Ratings	Environmental Specifications
Supply Voltage VS 16 Vdc Lead Temperature (soldering 2-4 sec.) 270°C	Temperature Ranges Compensated 0 to 70° C Operating -25 to 85° C Storage -40 to 125° C Humidity Limits 0 to 95% RH (non condensing)

Equivalent Circuit

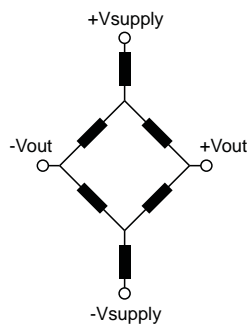

Input Resistance 15.0 k ohm

Output Resistance 3.0 k ohm

Approvals

MKT	DATE	MFG	DATE	ENG	DATE	QA	DATE
<input type="checkbox"/> As Is <input type="checkbox"/> With Change		<input type="checkbox"/> As Is <input type="checkbox"/> With Change		<input type="checkbox"/> As Is <input type="checkbox"/> With Change		<input type="checkbox"/> As Is <input type="checkbox"/> With Change	

ALL SENSORS

DS-0039 Rev C

01

Standard Pressure Ranges

Part Number	Operating Range	Proof Pressure	Burst Pressure
BARO-A-PRIME-MINI	600 to 1100 mbar	45 PSI	60 PSI
BARO-AF-PRIME-DIP-MINI	600 to 1100 mbar	45 PSI	60 PSI
BARO-AF-PRIME-MINI	600 to 1100 mbar	45 PSI	60 PSI

Performance Characteristics

BARO-A-PRIME-MINI, BARO-AF-PRIME-DIP-MINI, BARO-AF-PRIME-MINI

Parameter, note 1	Minimum	Nominal	Maximum	Units
Output Voltage @ 1100 mbar	94.7	95.7	96.7	mV
Output Voltage @ 600 mbar	51.2	52.2	53.2	mV
Output Voltage 0 to 1100 mbar	--	0.087	--	mV/mbar
Linearity, hysteresis error, note 3	--	0.05	0.25	%fs
Output Shift (0°C-70°C), note 2	--	--	±1	%fs

Specification Notes

NOTE 1: ALL PARAMETERS ARE MEASURED AT 12.0 VOLT EXCITATION, FOR THE NOMINAL FULL SCALE PRESSURE AND ROOM TEMPERATURE UNLESS OTHERWISE SPECIFIED. PRESSURE MEASUREMENTS ARE WITH POSITIVE PRESSURE APPLIED TO PORT B.

NOTE 2: SHIFT IS RELATIVE TO 25°C.

NOTE 3: MEASURED AT ONE-HALF FULL SCALE RATED PRESSURE USING BEST STRAIGHT LINE CURVE FIT.

All Sensors reserves the right to make changes to any products herein. All Sensors does not assume any liability arising out of the application or use of any product or circuit described herein, neither does it convey any license under its patent rights nor the rights of others.

Physical Dimensions

CFNS Package

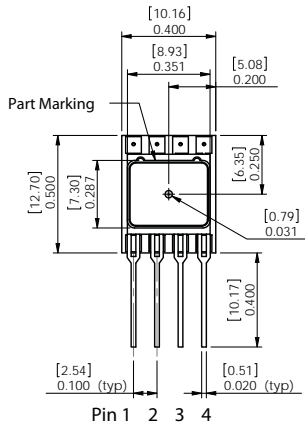
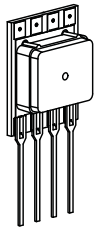

PINOUT:
 1: -Vs
 2: +Vout
 3: +Vs
 4: -Vout

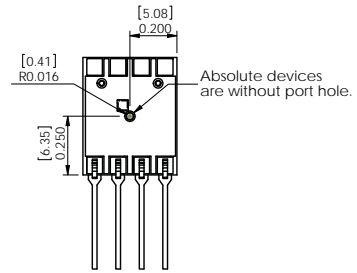
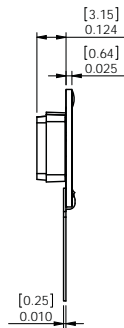

NOTES
 1) Dimensions are in inches [mm].
 2) For suggested pad layout, see drawing: PAD-01

CPND Package

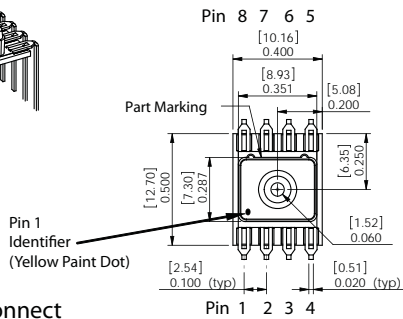
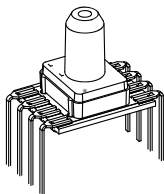

PINOUT:
 1: -Vs
 2: +Vout
 3: +Vs
 4: -Vout
 5: Do Not Connect
 6: Do Not Connect
 7: Do Not Connect
 8: Do Not Connect

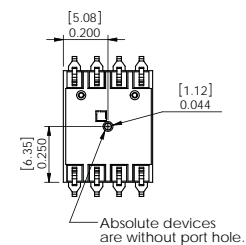
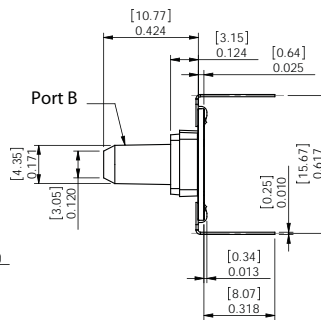

NOTES
 1) Dimensions are in inches [mm].
 2) For suggested pad layout, see drawing: PAD-03

CPNS Package

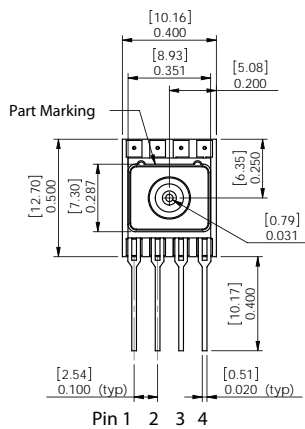
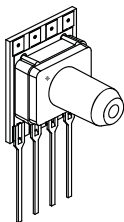

PINOUT:
 1: -Vs
 2: +Vout
 3: +Vs
 4: -Vout

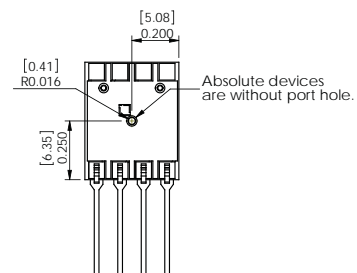
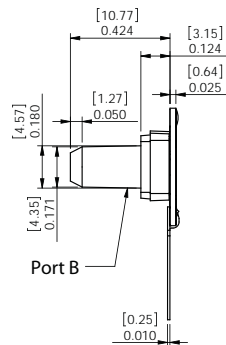

NOTES
 1) Dimensions are in inches [mm].
 2) For suggested pad layout, see drawing: PAD-01