

Ideal for Workpiece Position and Original Pressure Checking

- The 0 to 100 kPa model can be used for workpiece position checking.
- The 0 to 1MPa model is ideal for original pressure checking.
- Degree of protection conforms to IEC IP54.



 Be sure to read *Safety Precautions* on page 6.

Ordering Information

Pressure range		ON/OFF output		Linear output
		NPN open collector	PNP open collector	
Positive pressure	0 to 1 MPa	E8EB-10C	E8EB-10B	1 to 5 V
Positive pressure	0 to 100 kPa	E8EB-01C	E8EB-01B	
Negative pressure	0 to -100 kPa	E8EB-N0C2B	E8EB-N0B2B	

Ratings and Specifications

Item	Model	E8EB-10C	E8EB-10B	E8EB-01C	E8EB-01B	E8EB-N0C2B*	E8EB-N0B2B*
Power supply voltage	24 VDC $\pm 10\%$ with a ripple (p-p) of 5% max.						
Current consumption	20 mA max.						
Pressure type	Gauge pressure						
Permissible pressure range	0 to 1 MPa			0 to 100 kPa		0 to -100 kPa	
Pressure setting range	0 to 1 MPa			0 to 100 kPa		0 to -100 kPa	
Withstand pressure	2 MPa			290 kPa			
Applicable fluid	Noncorrosive and nonflammable gases						
Repeat accuracy (ON/OFF output)	$\pm 1\%$ FS max.						
Accuracy (linear output)	$\pm 3\%$ FS max.						
Hysteresis (linear output)	$\pm 1\%$ FS max.						
Differential travel (ON/OFF output)	0.4 to 1.6% FS max.						
Linearity (linear output)	$\pm 1\%$ FS max.						
Response time	5 ms max.						
Linear output	1 to 5 V with an output impedance of 20 Ω and a permissible resistive load of 10 k Ω min.						
ON/OFF output		NPN open collector	PNP open collector	NPN open collector	PNP open collector	NPN open collector	PNP open collector
	Load current	80 mA max.					
	Output applied voltage	30 VDC max.					
	Residual voltage	NPN: 0.4 V max. (at the load current of 20 mA) and 1 V max. (at the load current of 80 mA) PNP: 1.5 V max. (at the load current of 20 mA) and 2 V max. (at the load current of 80 mA)					
Indicator	Operation indicator (red)						
Ambient temperature	Operating: -10°C to 55°C (with no icing) Storage: -25°C to 70°C (with no icing)						
Ambient humidity	Operating: 35% to 85% (with no condensation)						
Temperature influence	$\pm 0.12\%$ FS/ $^{\circ}\text{C}$ between 0°C and 50°C			$\pm 0.2\%$ FS/ $^{\circ}\text{C}$ between 0°C and 50°C			
	$\pm 0.2\%$ FS/ $^{\circ}\text{C}$ max. between -10°C and 0°C or 50°C and 55°C			$\pm 0.3\%$ FS/ $^{\circ}\text{C}$ max. between -10°C and 0°C or 50°C and 55°C			
Voltage influence	$\pm 1\%$ FS max.						
Insulation resistance	100 M Ω min. (at 500 VDC) between current carry parts and case						
Dielectric strength	500 VAC for 1 min between current carry parts and case						
Vibration resistance	Destruction: 10 to 500 Hz, 1.5-mm double amplitude or 100 m/s ² whichever is smaller, for 2 hours each in X, Y, and Z directions						
Shock resistance	Destruction: 1,000 m/s ² 3 times each in X, Y, and Z directions						
Degree of protection	IEC 60529 IP54						
Pressure inlet	Rc(PT)1/8						
Connection method	Pre-wired (standard cable length: 2 m)						
Weight (packed state)	Approx. 120 g						
Pressure port material	Zinc die-cast						
Accessories	Instruction manual						

* These models are negative-pressure models.

Engineering Data (Typical)

Operating Pressure Fluctuation vs. Temperature
E8EB-01C

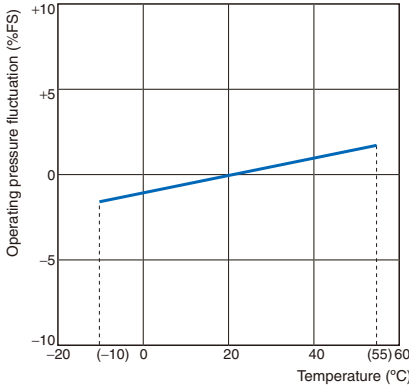

Differential Travel vs. Pressure
E8EB-01C

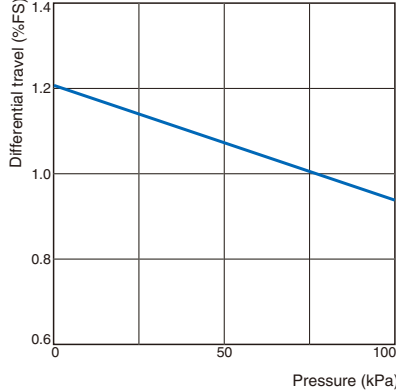

Operating Pressure Fluctuation vs. Voltage
E8EB-01C

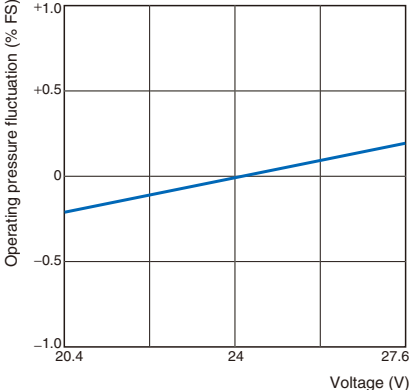

Linear Output Voltage vs. Pressure
E8EB

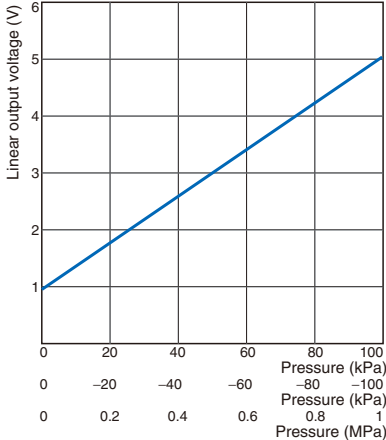

Linear Output Fluctuation vs. Temperature
E8EB-01C

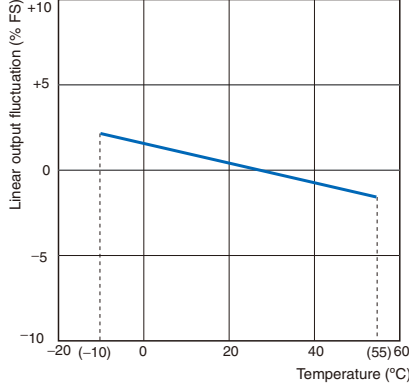

Linearity
E8EB-01C

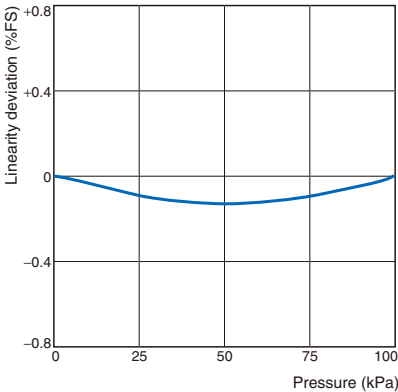

Linear Output Fluctuation vs. Voltage
E8EB-01C

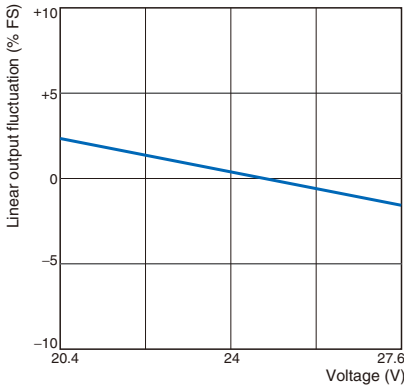

Gap Measurement

When checking the gap between the workpiece and the nozzle as shown in the illustration, the output of the E8EB varies with the surface roughness of the workpiece or the dimensions of the nozzle.

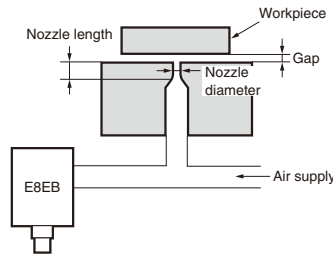

Examples with E8EB-01C (Typical)
Influence of Surface Roughness of Workpieces

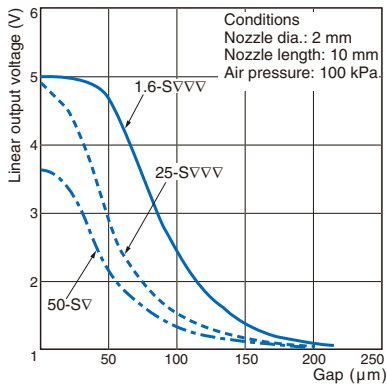

- The output varies with the surface roughness of the workpiece even though the gap is constant.
- The rougher the surface of the workpiece is, the more noticeable the variation of output is with a small gap. The variation rate versus gap change is not large in such cases.

Influence of Nozzle Diameter

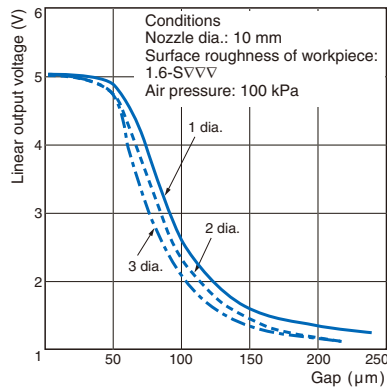

- The larger the nozzle diameter is, the larger the variation rate of output versus gap change is.

Influence of Nozzle Length

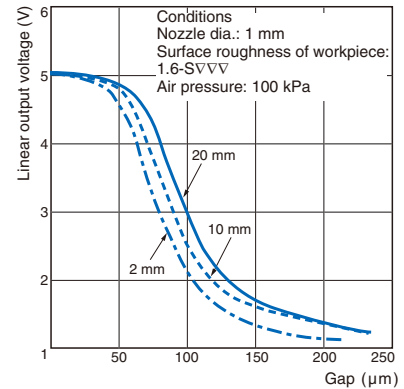

- The smaller the nozzle length is, the larger the variation rate of output versus gap change is.

I/O Circuit Diagrams

NPN Output

Model	Timing Charts	Output Circuit
E8EB-10C E8EB-01C		
E8EB-N0C2B		

PNP Output

Model	Timing Charts	Output Circuit
E8EB-10B E8EB-01B		
E8EB-N0B2B		

Safety Precautions

⚠ WARNING

This product is not designed or rated for ensuring safety of persons.



Do not use it for such purposes.

Precautions for Correct Use

Do not use the product in atmospheres or environments that exceed product ratings.

● Mounting

- If the diaphragm is damaged, the Pressure Sensor will not operate properly. Do not insert a screwdriver or steel wire into the interior of the pressure-sensitive parts through the pressure port.
- The pressure inlet has an R (PT) 1/8 taper screw and M5 female screw that conforms to JIS Standards. Apply sealing tape around the female taper screw so that no pressure leakage will occur.
- The most-suitable wrench is 17 mm in size.
- Make sure that the tightening torque of the M5 female screw is 9.8 N-m or less.

● Adjustment

Pressure Setting

- After the pressure is set with the pressure adjuster, cover the adjuster with the rubber bushing so that no dust or any other foreign material will penetrate into the interior of the E8EB.

Dimensions

(Unit: mm)

E8EB

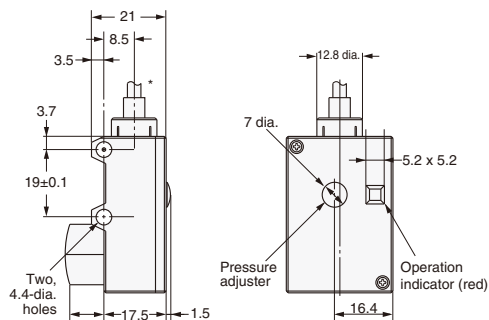
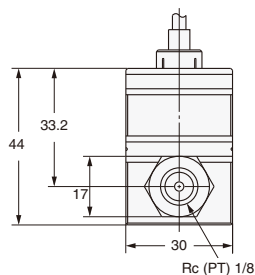
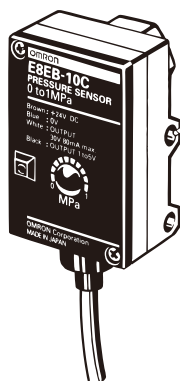

*3.8-dia. vinyl-insulated round cable with 4 conductors,
(Conductor cross-section: 0.2 mm², Insulator diameter: 1.0 mm);
Standard length: 2 m

Output Impedance

1. Measuring the Output Impedance of Voltage Output

Models

Figure 1

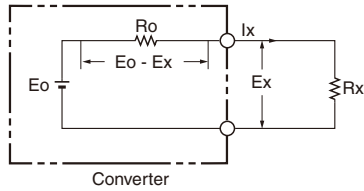

Ro : Output impedance
 Rx : Load resistance
 Eo : Output voltage (terminals open)
 Ex : Output voltage (with load Rx connected)
 Ix : Load current (with load Rx connected)

In Figure 1, the current (Ix) that flows when the load resistance (Rx) is connected is calculated as follows:

$$I_x = \frac{E_x}{R_x} = \frac{E_o - E_x}{R_o} \dots\dots(1)$$

The output impedance (Ro) in Equation (1) is calculated as follows:

$$R_o = R_x \left(\frac{E_o - E_x}{E_x} \right) \dots\dots(2)$$

The voltage (Eo) is measured when the output is open, followed by the voltage (Ex) when a load resistance (for example, the minimum value of the permitted load resistance of a transducer) is connected. The measured values Eo and Ex and the connected load resistance (Rx) are inserted into Equation 2 to calculate the output impedance (Ro) of the transducer.

2. Measuring the Output Impedance of Current Output

Models

In Figure 2, the voltage (Ex) of the output terminals when the load resistance (Rx) is connected is calculated as follows:

$$E_x = I_x R_x = (I_o - I_x) R_o \dots\dots(3)$$

The output impedance in Equation (3) is calculated as follows:

$$R_o = R_x \left(\frac{I_x}{I_o - I_x} \right) \dots\dots(4)$$

Here, the current (Io) is measured with the output short-circuited.

Figure 2

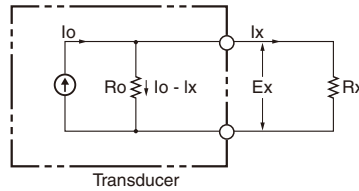

Ro : Output impedance
 Rx : Load resistance
 Io : Output current (output terminal short-circuited)
 Ix : Output current (with load Rx connected)
 Ex : Output voltage (with load Rx connected)

Next, the output current (Ix) is measured when a load resistance (for example, the maximum value of the permitted load resistance of a transducer) is connected. The measured values Io and Ix and the value of the connected load resistance (Rx) are inserted into Equation 4, and the output impedance (Ro) of the transducer is calculated. The output impedance of the transducer introduced here is the value for normal operation.

3. Desirable Output Impedance

In general, it is best to make the output impedance of a voltage output transducer as small as possible, i.e., as close to 0 W as possible, to minimize the effects of load fluctuations on the transducer. For a current output transducer, the opposite is true: the higher the impedance (the closer to infinite impedance), the better.

4. Example of Calculation Using Impedance

$$\text{Error in analog voltage output} = \left(1 - \frac{R_x}{R_o + R_x} \right) \times 100\%$$

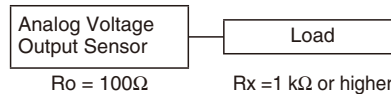

Rx	Error
1kΩ	Approximately 10%
10Ω	Approximately 1%

Pressure Sensors Technical Guide

General Precautions For precautions on individual products, refer to the *Safety Precautions* in the individual product information.

WARNING

These products cannot be used in safety devices for presses or other safety devices used to protect human life. These products are designed for use in applications for sensing workpieces and workers that do not affect safety.



Precautions for Safe Use

Withstand Pressure

Do not apply a pressure higher than the rated withstand pressure. Applying a pressure higher than this may cause damage.

Operating Environment

Do not use the products in an environment where there are explosive or inflammable gases.

Power Supply Voltage

Do not use a voltage that exceeds the power supply voltage range. Using a voltage that exceeds the range may cause burning.

Load Short-circuiting

Do not short-circuit the load. Doing so may cause explosion or burning.

Incorrect Wiring

Be sure that the power supply polarity and other wiring is correct. Incorrect wiring may cause explosion or burning.

Precautions for Correct Use

- When using a Sensor that supports non-corrosive gas as the applicable fluid, use an air filter to remove moisture and oil from the gas.
- Do not insert any wire or other object into the pressure port. Doing so may damage the pressure elements and cause a malfunction.
- Do not use the Sensor alongside high-voltage lines or power lines.
- Mount the Sensor so that it is not subject to ultrasonic vibration.
- Do not apply a tensile force higher than 30 N to the cable or connector.
- The cable can be extended to a maximum of 10 m. For details, see the output impedance section on the previous page.

Read and Understand This Catalog

Please read and understand this catalog before purchasing the products. Please consult your OMRON representative if you have any questions or comments.

Warranty and Limitations of Liability

WARRANTY

OMRON's exclusive warranty is that the products are free from defects in materials and workmanship for a period of one year (or other period if specified) from date of sale by OMRON.

OMRON MAKES NO WARRANTY OR REPRESENTATION, EXPRESS OR IMPLIED, REGARDING NON-INFRINGEMENT, MERCHANTABILITY, OR FITNESS FOR PARTICULAR PURPOSE OF THE PRODUCTS. ANY BUYER OR USER ACKNOWLEDGES THAT THE BUYER OR USER ALONE HAS DETERMINED THAT THE PRODUCTS WILL SUITABLY MEET THE REQUIREMENTS OF THEIR INTENDED USE. OMRON DISCLAIMS ALL OTHER WARRANTIES, EXPRESS OR IMPLIED.

LIMITATIONS OF LIABILITY

OMRON SHALL NOT BE RESPONSIBLE FOR SPECIAL, INDIRECT, OR CONSEQUENTIAL DAMAGES, LOSS OF PROFITS, OR COMMERCIAL LOSS IN ANY WAY CONNECTED WITH THE PRODUCTS, WHETHER SUCH CLAIM IS BASED ON CONTRACT, WARRANTY, NEGLIGENCE, OR STRICT LIABILITY.

In no event shall responsibility of OMRON for any act exceed the individual price of the product on which liability is asserted.

IN NO EVENT SHALL OMRON BE RESPONSIBLE FOR WARRANTY, REPAIR, OR OTHER CLAIMS REGARDING THE PRODUCTS UNLESS OMRON'S ANALYSIS CONFIRMS THAT THE PRODUCTS WERE PROPERLY HANDLED, STORED, INSTALLED, AND MAINTAINED AND NOT SUBJECT TO CONTAMINATION, ABUSE, MISUSE, OR INAPPROPRIATE MODIFICATION OR REPAIR.

Application Considerations

SUITABILITY FOR USE

OMRON shall not be responsible for conformity with any standards, codes, or regulations that apply to the combination of products in the customer's application or use of the product.

At the customer's request, OMRON will provide applicable third party certification documents identifying ratings and limitations of use that apply to the products. This information by itself is not sufficient for a complete determination of the suitability of the products in combination with the end product, machine, system, or other application or use.

The following are some examples of applications for which particular attention must be given. This is not intended to be an exhaustive list of all possible uses of the products, nor is it intended to imply that the uses listed may be suitable for the products:

- Outdoor use, uses involving potential chemical contamination or electrical interference, or conditions or uses not described in this catalog.
- Nuclear energy control systems, combustion systems, railroad systems, aviation systems, medical equipment, amusement machines, vehicles, safety equipment, and installations subject to separate industry or government regulations.
- Systems, machines, and equipment that could present a risk to life or property.

Please know and observe all prohibitions of use applicable to the products.

NEVER USE THE PRODUCTS FOR AN APPLICATION INVOLVING SERIOUS RISK TO LIFE OR PROPERTY WITHOUT ENSURING THAT THE SYSTEM AS A WHOLE HAS BEEN DESIGNED TO ADDRESS THE RISKS, AND THAT THE OMRON PRODUCT IS PROPERLY RATED AND INSTALLED FOR THE INTENDED USE WITHIN THE OVERALL EQUIPMENT OR SYSTEM.

Disclaimers

CHANGE IN SPECIFICATIONS

Product specifications and accessories may be changed at any time based on improvements and other reasons.

It is our practice to change model numbers when published ratings or features are changed, or when significant construction changes are made. However, some specifications of the product may be changed without any notice. When in doubt, special model numbers may be assigned to fix or establish key specifications for your application on your request. Please consult with your OMRON representative at any time to confirm actual specifications of purchased product.

DIMENSIONS AND WEIGHTS

Dimensions and weights are nominal and are not to be used for manufacturing purposes, even when tolerances are shown.

ERRORS AND OMISSIONS

The information in this catalog has been carefully checked and is believed to be accurate; however, no responsibility is assumed for clerical, typographical, or proofreading errors, or omissions.

PERFORMANCE DATA

Performance data given in this catalog is provided as a guide for the user in determining suitability and does not constitute a warranty. It may represent the result of OMRON's test conditions, and the users must correlate it to actual application requirements. Actual performance is subject to the OMRON Warranty and Limitations of Liability.

PROGRAMMABLE PRODUCTS

OMRON shall not be responsible for the user's programming of a programmable product, or any consequence thereof.

COPYRIGHT AND COPY PERMISSION

This catalog shall not be copied for sales or promotions without permission.

This catalog is protected by copyright and is intended solely for use in conjunction with the product. Please notify us before copying or reproducing this catalog in any manner, for any other purpose. If copying or transmitting this catalog to another, please copy or transmit it in its entirety.